

At Mac

THRESHOLD

by Warren Schwader & Ken Williams

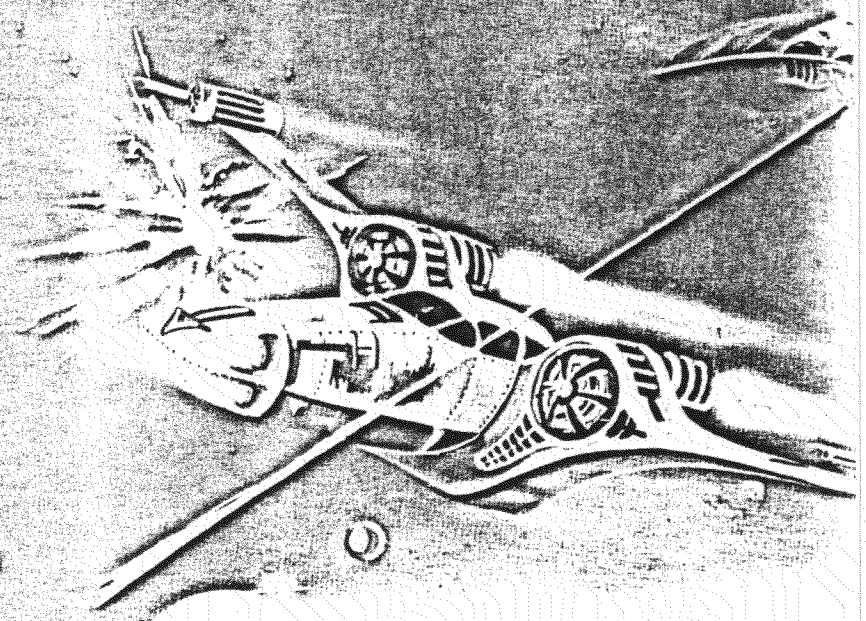

ON-LINE systems

A DARK AGE FOR THE EARTH FEDERATION

Home planet is under attack and our colonies are raided unmercifully. Space has become a death wish as more and more enemy ships find their way past the defenses and into the paths of friendly trade supplies. But to go through however, the pilot of the Federation Battle THRESHOLD it is your mission to clear the ways of pirate fleets so that supplies may get to the defense base that protect the world and its colonies from the lawless invaders that roam the galaxy.

Joystick Control
Graphics & Sound

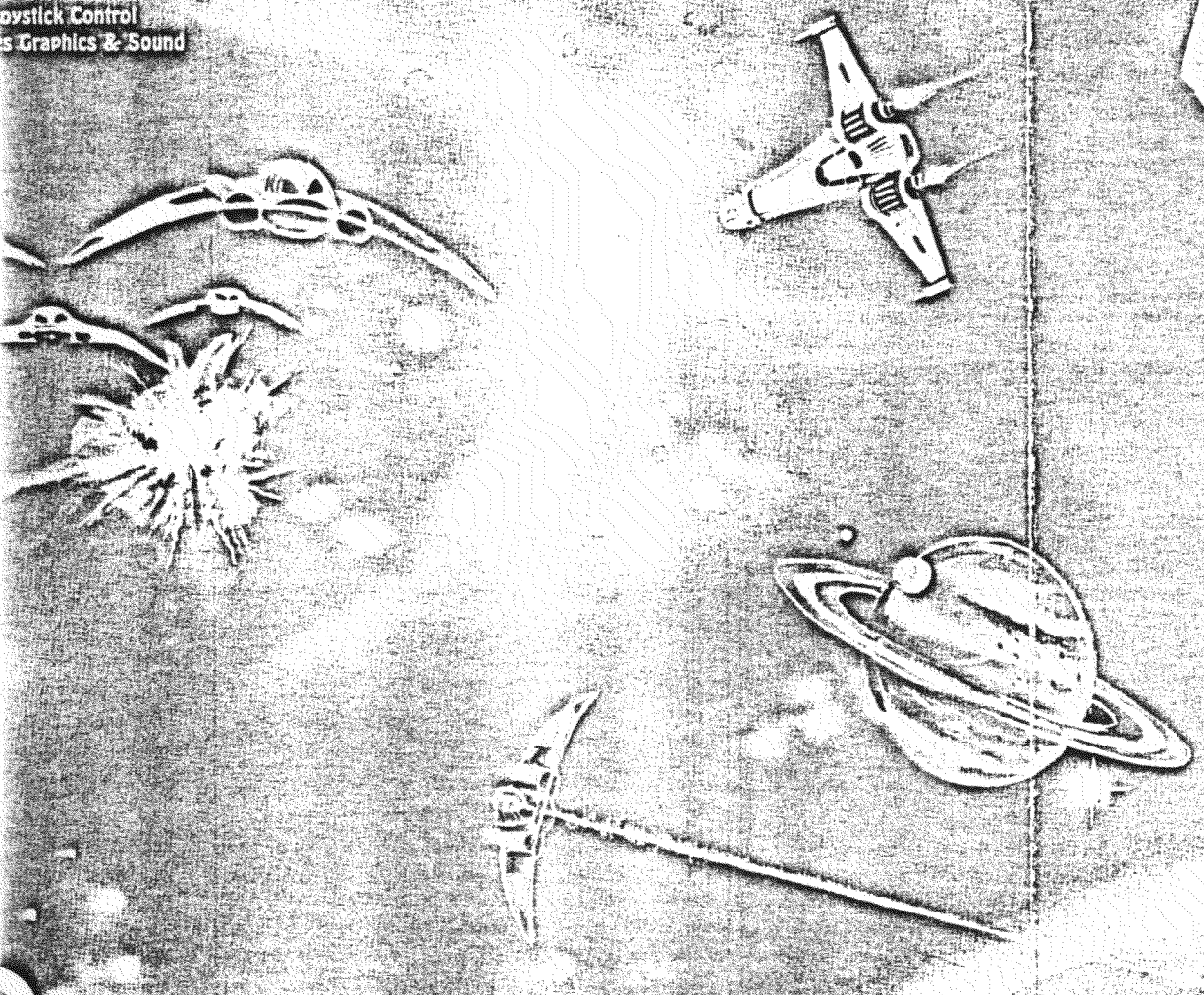

ON-LINE systems

36575 MUDGE RANCH ROAD
COARSE GOLD, CA 93614 209-683-5858

On-line

THRESHOLD

A FEW WORDS ABOUT YOUR SHIP

The Earth Federation Ship THRESHOLD is the best in its fleet and features armaments not usually found in ships of its class. Amongst these is the hyper warp driver that, when activated, slows down time and speed for a short period. Because of the energy needed for this weaponry, the driver may only be used once during each flight.

The THRESHOLD is also equipped with delta class lasers. These lasers are extremely heat sensitive. You will have to be careful to keep them from overheating during the course of a battle.

WARNING: If your lasers overheat at any time, you will experience a temporary malfunction of all weaponry.

TO BEGIN PLAY

- A. Remove cartridge
- B. Connect Joystick in port 1.
- C. Place Diskette in drive 1.
- D. Power up system
- E. Press joystick button when the word "THRESHOLD" appears on screen or: press
 - (1) Slow Speed with star background
 - (2) Slow speed without star background
 - (3) Fast speed with star background
 - (4) Fast speed without star background

TO CONTROL THE THRESHOLD

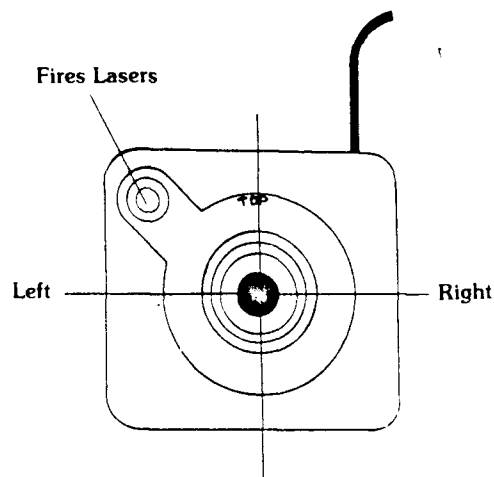

Pulling Joystick straight back engages Hyper warp.

INFORMATION ABOUT YOUR MISSION

There are five ships allowed per flight mission. Your flight is over when your ships are destroyed or when you're out of fuel. Refueling is done at the mother ship.

An extra ship is given at the score of 50,000 points and every 100,000 points thereafter.

Your mission is complete when you identify and destroy the last of the aliens. The last group of aliens will be very special and very easy to identify because of their characteristics.

TO PLAY AGAIN press the Joystick button once to return to main screen.

TO SUSPEND PLAY press any key.

TO RESTART GAME: Press start key after your ship crashes.

THANK YOU FOR PLAYING THRESHOLD!

Warren Schwader and Ken Williams



36575 Mudge Ranch Road
Coarsegold, CA 93614
209-683-6858
