

ATARI

850™ INTERFACE MODULE SERVICE MANUAL



ATARI SERVICE MANUAL
400/800 PERSONAL COMPUTER SYSTEMS
850TM INTERFACE MODULE

NOTICE

This document contains proprietary information
and may not be reproduced without the written
consent of ATARI Corporation.

Publication Number CS 400/800-5004-B

Copyright 1981, ATARI, Inc.

NOTICE OF CHANGES

This NOTICE of CHANGES form contains instructions for changes to be made to an ATARI Personal Computer System Manual. The title, number and issue date of the affected document are given below.

The NOTICE OF CHANGES page indicates the affected page number and action required. The change may be specified as "add" or "delete" or "replace", etc.

This issue accompanies ___ ORIGINAL PUBLICATION, REV. B _____.

The next change, if issued, will have the number ___ B1 _____.

Keep all NOTICE OF CHANGES in the affected document to maintain a record of changes.

TITLE OF DOCUMENT ___ Interface Module Service Manual _____

ATARI NUMBER ___ CS 400/800-S004-B ___ DATE OF PUBLICATION ___ 4/81 _____

NOTICE OF CHANGES number ___ B0 ___ NUMBER OF PAGES ___ 0 ___ DATE OF ISSUE ___ 4/81 _____

TABLE OF CONTENTS

Page

1. GENERAL INFORMATION

INTRODUCTION	1-2
DESCRIPTION OF ATARI 850 INTERFACE MODULE	1-2
HOW TO USE THIS MANUAL	1-2
INSTALLATION	1-4

2. PRINCIPLES OF OPERATION

INTRODUCTION	2-3
BLOCK DIAGRAM	2-3
Power supply	2-3
Microprocessor	2-3
Clock	2-3
4k ROM	2-4
PIA (Two 6532s)	2-4
Local RAM	2-4
850 Address Bus and Data Bus	2-4
Buffers	2-4
Printer Port	2-5
Serial Ports	2-5
System I/O Port	2-5
Power-on Reset	2-5
OPERATION	2-6
General	2-6
Bootstrap Without Disk Drive	2-7
Bootstrap With Disk Drive	2-7
I/O Operation	2-8

3. MAINTENANCE AND SERVICE

INTRODUCTION	3-2
WORK STATION	3-2
Safety	3-2
Tools and Supplies	3-3
DISASSEMBLY AND ASSEMBLY	3-5
Disassembly	3-5
Assembly	3-6
PREVENTIVE MAINTENANCE	3-6
TROUBLE SHOOTING	3-8
Introduction	3-8
Basic Set-Up for Trouble Shooting	3-8
When the 850 Boots	3-8
Power supply (+10 v. and -8 v.)	3-10
Local RAM	3-11
Port Buffers	3-12
Testing each port	3-12
Checking address lines	3-13

TABLE OF CONTENTS (cont.)

	Page
TROUBLE SHOOTING	
When the 850 Does Not Boot	3-13
Power Supply (5 VDC)	3-13
Clock Circuit	3-14
Power-On Reset	3-15
Microprocessor	3-16
ROM	3-16
Local RAM	3-16
System I/O Port Buffer	3-17
Grounds	3-17
Printer Port	3-18
Trouble Shooting Guide	3-20

FIGURES

Figure 1-1.	Installation of the Interface Module.	1-3
Figure 2-1.	Block Diagram of the Interface Module	2-2
Figure 3-1.	Removal of PC Board from the bottom shell	3-4
Figure 3-2.	Test Points for the power supply	3-9
Figure 3-3.	Trouble Shooting Guide	3-20
Figure A3-1.	Schematic of the Power Supply	A3-2
Figure A3-2.	Test Points for trouble shooting the Power Supply	A3-3
Figure A4-1.	Schematic of the Clock Circuit.	A4-2
Figure A4-2.	Test Points for trouble shooting the Clock Circuit.	A4-3
Figure A5-1.	Simplified Block Diagram of the 6532 Peripheral Interface Adapter	A5-2
Figure A5-2.	Pin assignments of the 6532	A5-3
Figure A5-3.	Block Diagram of the Programmable Interval Timer of the 6532	A5-9
Figure A11-1.	Schematic	A11-2
Figure A11-2.	Printer Port Timing Diagram	A11-3
Figure A11-3.	Pin functions of the Printer Port (15-pin female connector)	A11-4
Figure A11-4.	Pin functions of Serial Port No. 1 (9-pin female connector)	A11-5
Figure A11-5.	Pin functions of Serial Port Nos. 2 and 3 (9-pin female connectors)	A11-6
Figure A11-6.	Pin functions of Serial Port No. 4 (9-pin female connector)	A11-7
Figure A11-7.	Hook-Up of Serial Port No. 4 with a 20 mA current loop.	A11-8
Figure A11-8.	Pin functions of the System I/O Port which are used by the Interface Module (13-pin male connector--J106 and J107)	A11-9
Figure A11-9.	Placement of ICs on the PC Board.	A11-10

TABLES

Table 3-1.	Trouble shooting when the 850 boots	3-21
Table A5-1.	Address Coding of the 6532	A5-4
Table A7-1.	Baud Rates	A7-3
Table A8-1a	Complete Parts List and Kit Parts List (part a)	A8-3
Table A8-1b	Complete Parts List and Kit Parts List (part b)	A8-4

APPENDICES

APPENDIX 1. SYSTEM I/O BUS PROTOCOL FOR THE 850

APPENDIX 2. NOTE ON CABLES

APPENDIX 3. POWER SUPPLY

Figure A3-1. SCHEMATIC OF THE POWER SUPPLY

Figure A3-2. TEST POINTS FOR TROUBLE SHOOTING THE POWER SUPPLY

APPENDIX 4. CLOCK CIRCUIT

Figure A4-1. SCHEMATIC OF THE CLOCK CIRCUIT

Figure A4-2. TEST POINTS FOR TROUBLE SHOOTING THE CLOCK CIRCUIT

APPENDIX 5. PERIPHERAL INTERFACE ADAPTER (6532)

PERIPHERAL INTERFACE ADAPTER (6532)

Address Decode and Chip Select Logic

Data Direction Register

Buffers

RAM

Programmable Interval Timer

Interrupt Register

DIFFERENCES BETWEEN PORTS A AND B

Only Port A can generate an Interrupt

Port B Buffers can source Higher Current

Read Operations Differ

PROGRAMMABLE INTERVAL TIMER

Figure A5-1. SIMPLIFIED BLOCK DIAGRAM OF THE 6532.

Figure A5-2. PIN ASSIGNMENTS OF THE 6532

Figure A5-3. BLOCK DIAGRAM OF THE PROGRAMMABLE INTERVAL TIMER

Table A5-1. ADDRESS CODING

APPENDIX 6. HOW TO DETERMINE REVISION LEVEL

APPENDIX 7. PORT TEST PROGRAM

Table A7-1. BAUD RATES

APPENDIX 8. COMPLETE PARTS LIST AND PARTS LIST OF SERVICE AND REPAIR KIT

APPENDIX 9. CHECKING ADDRESS LINES

APPENDIX 10. ORDERING AND REPORTING INFORMATION

APPENDIX 11. SCHEMATIC, TIMING DIAGRAM AND PIN FUNCTIONS

Figure A11-1. SCHEMATIC

Figure A11-2. PRINTER PORT TIMING DIAGRAM

Figure A11-3. PIN FUNCTIONS OF THE PRINTER PORT (15-PIN FEMALE CONNECTOR)

Figure A11-4. PIN FUNCTIONS OF SERIAL PORT NO. 1 (9-PIN FEMALE CONNECTOR)

Figure A11-5. PIN FUNCTIONS OF SERIAL PORTS NOS. 2 and 3 (9-PIN FEMALE CONNECTORS)

Figure A11-6. PIN FUNCTIONS OF SERIAL PORT NO. 4 (9-PIN FEMALE CONNECTOR)

Figure A11-7. HOOK-UP OF SERIAL PORT NO. 4 WITH A 20 mA CURRENT LOOP

Figure A11-8. PIN FUNCTIONS OF SYSTEM I/O PORT (13-PIN MALE CONNECTOR)

Figure A11-9. PLACEMENT OF ICs ON PC BOARD



CHAPTER 1

General Information

INTRODUCTION

The 850 Interface Module Service Manual is a reference guide for the service technician. The information given in this manual, in conjunction with ATARI training, enables a service technician to install, operate, maintain and repair the 850 Interface Module.

DESCRIPTION OF THE 850 INTERFACE MODULE

The ATARI 850 Interface Module is a necessary component for establishing communication between a console of an ATARI Personal Computer and a peripheral complying with the EAI RS-232-C standard (usually referred to as "an RS232 peripheral").

The Interface Module connects between the console and the RS232 peripheral. The Interface Module also has a parallel port, referred to as the Printer Port. Up to four RS232 peripherals may be connected to the Interface Module at one time, as well as a printer.

HOW TO USE THIS MANUAL

This manual is organized in three Chapters:

- Chapter 1, General Information
- Chapter 2, Operation
- Chapter 3, Maintenance and Service

Chapter 1 contains general information about the Interface Module and the 400/800 system. It also contains instructions about hooking up the Interface Module with the 400 or the 800 Personal Computer System.

Chapter 2 explains the theory of operation of the Interface Module and explains the sequence of events that take place when it operates.

Chapter 3 contains maintenance information, including preventive maintenance, instructions for disassembly and assembly, and trouble shooting.

More technical information and specifications are collected in the appendices.

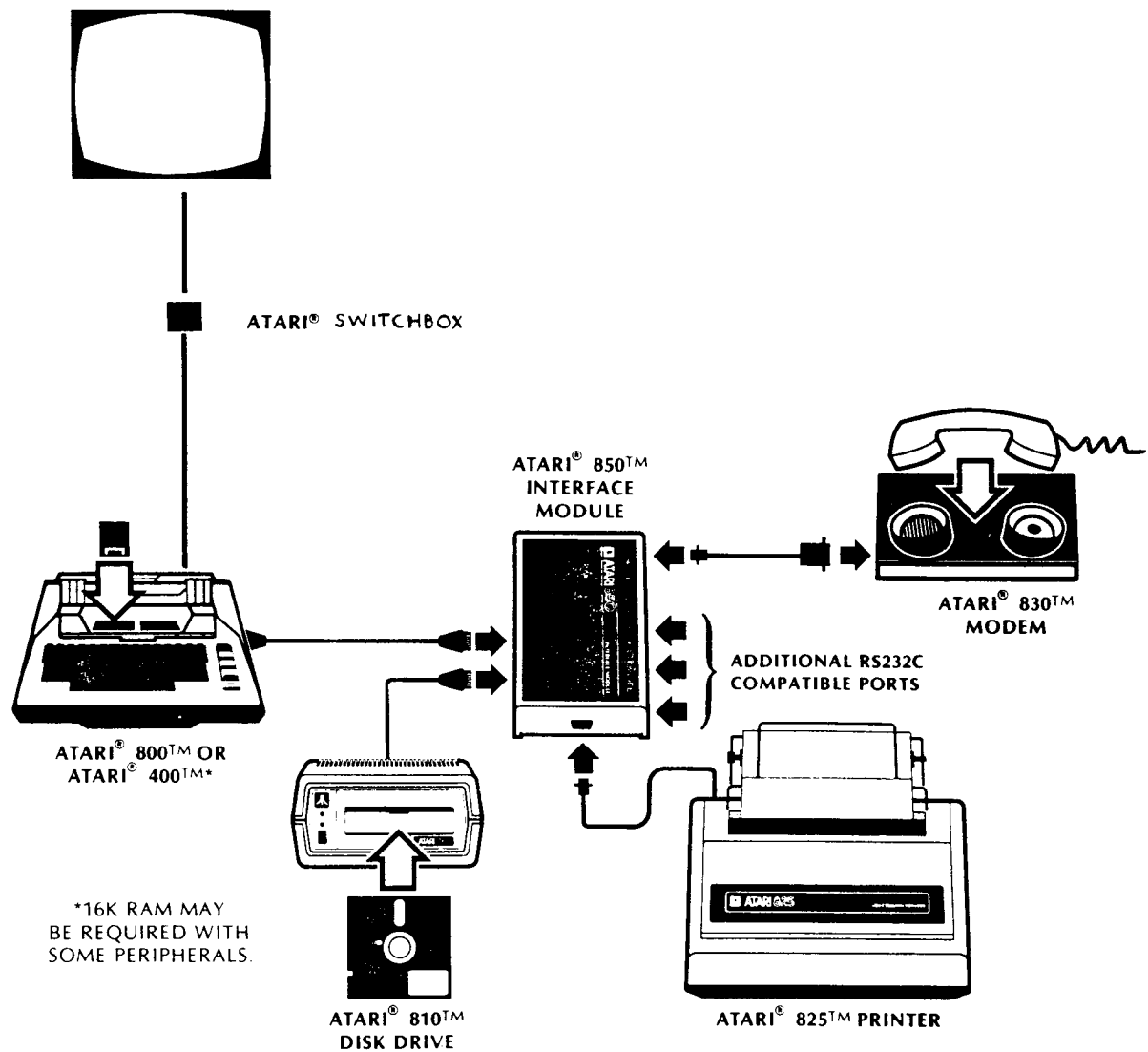

Figure 1-1. Installation of the Interface Module. Your TV set and ATARI 825 Printer are plugged into a wall outlet. Each other unit is powered by the Power Adapter that comes with the unit.

If you are not familiar with the Interface Module, you should read this manual completely. Once you have experience with the maintenance and repair of the 850, you will become less dependent on this manual and the reference material in the appendices will probably be sufficient for maintenance purposes.

If you are servicing an Interface Module that has come to you because of faulty operation, you should use the trouble-shooting guide in Chapter 3.

If new information on this product becomes available, ATARI sends a form called "Notice of Changes" to all those authorized to receive the information. If you are not on ATARI's authorized list, you will not receive this information. In that case, you will not know whether this copy of the publication is up to date.

If this copy of the publication has been properly maintained, it should contain its own history of up-dating. All Notice of Changes forms should be in this copy. All Notices should be consecutively numbered. The date of the last Notice tells you how old the information in this copy of the publication is.

Later revisions of the firmware in this product may have functions not possessed by earlier revisions. To determine revision number, consult Appendix 6.

INSTALLATION

The installation of the Interface Module is illustrated in Figure 1-1. The figure shows how the Interface Module interconnects with various peripheral devices, not the configuration that you will use to test the Interface Module. The test configuration is very simple, consisting only of the Interface Module and the 400/800 console. This is more fully explained in Appendix 3.

CHAPTER 2

Principles of Operation

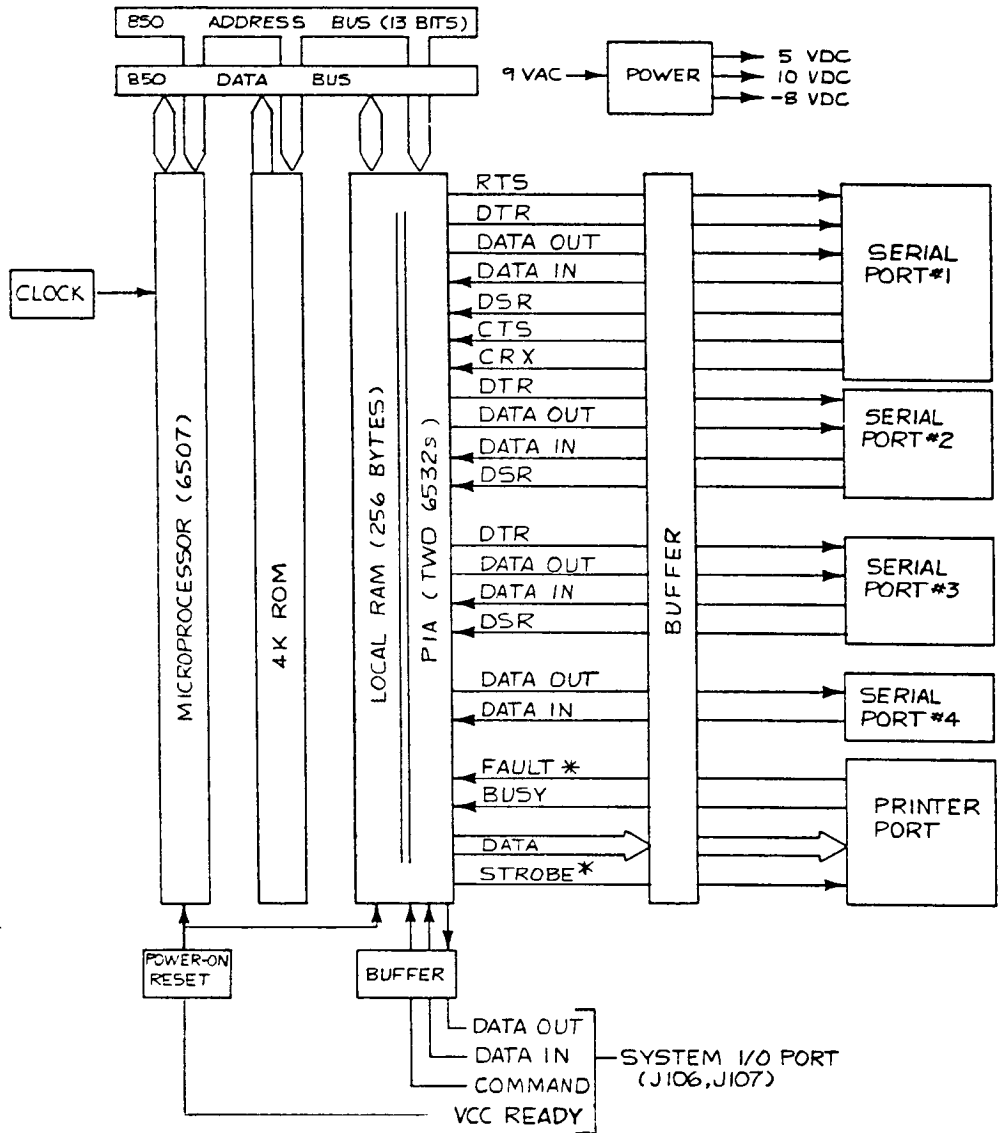

Figure 2-1. Block Diagram of the Interface Module, showing principal functions, signals and directions of signal flow. See text.

INTRODUCTION

Principles of operation are described in this Chapter. A simplified block diagram is given first, followed by a description of each major element of the block diagram. Finally, the operation of the Interface Module on power-up and during its use for I/O is described.

BLOCK DIAGRAM

A simplified block diagram of the 850 Interface Module is given in Figure 2.1. A complete schematic diagram is given in Appendix 11. The descriptions that follow refer to the block diagram.

POWER SUPPLY

The 9 VAC supplied by the ATARI Power Adapter is converted to DC voltages by power conversion circuits in the 850. The power supply is fully described in Appendix 3.

MICROPROCESSOR

The microprocessor used in the 850 is a 6507. This microprocessor is one of the 6500 series. It can execute all 6500 instructions. It has an 8K address space (13 address pins).

The function of the microprocessor is to control communication among all the components of the 850 and to control communications (through the PIAs--see below) with the System I/O Port.

CLOCK

The clock signal is generated by the clock circuit on the Interface Module. The signal is applied to the microprocessor and determines its speed of execution of instructions.

The clock circuit is fully described in Appendix 4.

4K ROM

The 4K ROM contains the operating system of the Interface Module. The instructions contained in the ROM are executed by the 6507 microprocessor.

PERIPHERAL INTERFACE ADAPTORS

Peripheral Interface Adaptor (PIA) is the name used in this manual for the 6532 chip. This chip is also called a RAM, I/O, Timer (RIOT). There are two 6532s in the 850. Each 6532 contains two 8-bit I/O ports, 128 bytes of RAM and a programmable Interval Timer.

The function of the PIAs is to send data and control signals to and from the ports of the 850 and the System I/O Port. The PIAs are controlled by the 6507 microprocessor. The PIAs are fully described in Appendix 5.

LOCAL RAM

The local RAM in the block diagram is the RAM contained in the two 6532s. The capacity is $2 \times 128 = 256$ bytes. The RAM is separated from the PIAs in the block diagram for the sake of clarity.

The function of Local RAM is to act as a temporary store for commands and data to be sent to or from a port.

850 ADDRESS BUS AND DATA BUS

Address and data lines connect the PIAs, the microprocessor and the ROM. These are separate from the address and data buses of the 400/800 itself. The 400/800 communicates with the 850 only through the serial I/O port of the 400/800.

BUFFERS

The large, expensive LSI chips of the 850 are isolated from peripherals attached to the I/O connectors of the 850 by buffers. In this context, "buffer" means a protective, reactive medium. For example, the output to the Printer Port drives transistors, which, in turn,

drive the printer electronics. The buffers of the serial ports comply with the EIA RS-232-C standard. Besides implementing the standard, these components also protect the 850 by limiting current flow in the I/O ports of the 850.

The block labelled BUFFER actually represents several different types of device. These devices are different for Ports 1, 2 and 3, Port 4, and the Printer Port.

PRINTER PORT

The Printer Port is the parallel port of the 850. Eleven of the 32 I/O lines of the 6532s go to the Printer Port. These lines are used for 8 data bits, a data strobe, a printer-busy line, and a line to signal "printer is connected".

SERIAL PORTS

There are four serial I/O ports. Port #1 supports the most RS-232-C signals. Ports #2 and #3 have send and receive and two handshaking signals. Port #4 is designed to permit connection to a teletype machine with 20 mA current loop, or to send and receive RS-232-C data.

SYSTEM I/O PORT

The 400/800 and the 850 communicate with each other through the System I/O Port. The System I/O Port has two data lines (one to send and one to receive). Serial data are passed over these data lines. Other port signals used are those indicating that the computer is powered on and that an I/O command is being issued.

The computer's serial I/O port is always referred to in this manual as the "System I/O Port" to distinguish it from the four (RS-232-C) serial ports of the Interface Module.

POWER-ON RESET

The power-on reset is a circuit that sends a reset pulse to the microprocessor and the PIAs when the 850 is powered on. If the 400/800 is not powered on too, the power-on reset circuit keeps the RESET

pins of the the microprocessor and the PIAs pulled low. Thus, so long as the computer is disconnected or not powered on, the 850 stays RESET. This action ensures that the 850 is always properly initialized.

When the RESET goes high, the 850 is ready to respond the next time the COMMAND line goes low (see the section on OPERATION).

OPERATION

GENERAL

The 850 Interface Module is one of several peripherals that may be connected to the 400/800 console. The 850 is selected under the central I/O facility of the 400/800 Personal Computer System. The selection process is described partially in various ATARI publications, including the BASIC Reference Manual. It is not essential to understand the details of the process, but it is necessary to understand the general principles.

A handler must be loaded into computer RAM (or must exist in ROM) for any peripheral that is to be used. Handlers for all peripherals are not in RAM all the time. If a peripheral is not being used, the system need not dedicate any of its facilities to that peripheral.

The computer's Operating System has to "know" what peripherals are connected (and powered). More specifically, to use a serial port, it has to know whether the 850 is connected as part of the system. On the other hand, the 850 has to "know" that the 400/800 console has been powered up, if the 850 has to boot, since the 850 should not attempt to boot until the 400/800 is ready.

On power-up, the 400/800 pulls its I/O port Command line low and sends a Disk Drive #1 status request command byte on the Data-Out line. The 850 will respond if there is no Disk Drive #1 attached and powered. If a Drive #1 is attached and powered, it will respond and the 850 will not.

When the 400/800 is powered up, the signal Vcc READY comes in to the 850 on the I/O cable (pin 10, J106, J107). This signal unlatches the power-on reset circuit of the 850.

The 850 now looks at the COMMAND line on the system I/O port (pin 7, J106). When the COMMAND line

goes low, the 850 reads the next 5 bytes on the data line (pin 5, J106). The data rate is 19.2 kBaud. These 5 bytes concern the command itself, and they are called the "Command Frame".

The first byte in the Command Frame is the Device Identification Number. At power-on, this number for the 850 is 31 hex (i.e., the same as for Drive #1). If the command is for the 850 (according to the Identification Number), the 850 checks the validity of the information received in the Command Frame, and sends back an ACK signal, provided no error was detected. If an error is detected, an appropriate error message, such as "ERROR 143", is displayed.

After completing the operation specified in the Command Frame, the 850 sends a DONE signal to the 400/800. The 400/800 must receive the DONE signal before proceeding.

BOOTSTRAP WITHOUT DISK DRIVE

The 850 must be powered before the 400/800 console. When the 400/800 is powered up, the 850 sees the Vcc READY line go high, releasing the 850's power-on reset circuit. The 850 then responds after the COMMAND line goes low. The 400/800 sends Disk Drive #1 a status request, which would be repeated 28 times. The 850 responds on the 27th request. The 850 masquerades as Disk Drive #1 during the boot procedure. The 850 responds to the Disk Drive #1 command frame and passes information to the console so that the handler for the 850 serial ports can be established in the Operating System.

BOOTSTRAP WITH DISK DRIVE

If Disk Drive #1 is connected and powered, it responds to the disk request of the 400/800. Most commonly, DOS is then loaded from Disk Drive #1. Later versions of DOS include a procedure to load the 850 handler from the 850 automatically, if the 850 is connected and powered. For details about the procedure consult the Operator's manual for the version of DOS you are using.

I/O OPERATION

Once booted (or even if not booted), the 850 waits for the next command. It monitors the COMMAND line. It decodes all identification numbers in every Command Frame and proceeds when it decodes a number that applies to itself. The identification numbers are 40 hex (Printer Port) and 50 through 53 hex (Serial Ports #1 through #4).

A Status command returns information about a port. Other commands to the 850 are of two types--configuration commands and I/O commands. These are fully described in the Interface Module Operators Manual. I/O commands result in input or output through the 850's ports, whereas configuration commands do not.

Various configuration commands set the Baud rate, the number of bits per word, the number of stop bits at the end of each word, the type of parity, if any, to be used, etc. A particular configuration is set by filling certain Local RAM locations with appropriate data.

In BASIC, these configuration commands are:

- XIO 32
- XIO 34
- XIO 36
- XIO 38 (performed by handler in the 400/800, not the 850)
- XIO 40

Various I/O commands send data to a port or read data from a serial port.

In BASIC, these I/O commands are:

- GET
- PUT
- INPUT
- PRINT

You must refer to the Interface Module Operators Manual for detailed information on how to use these commands. However, this manual and the procedures it describes have been designed to enable you to maintain, service and repair the Interface Module without a detailed understanding of how to use these BASIC commands.

CHAPTER 3

Maintenance and Service

INTRODUCTION

This chapter contains information on maintenance and service procedures, including disassembly and assembly, preventive maintenance, and trouble shooting.

WORK STATION

SAFETY

You must observe relevant industrial safety precautions when working with the Interface Module and with ATARI Personal Computer Systems in general. A current of a few milliamps can be fatal. Where possible, do not expose yourself to high voltages (over 30 Volts). Remember that low supply voltages can be converted into very high voltages by inductive effects. Observe caution when interrupting current flow (breaking a circuit), since high voltages are usually generated at that time.

Integrated circuits can be damaged by static charges generated in normal work environments. You must make your work station static-free. You should have a grounded metal table and all test instruments should also be grounded. The table should be covered with an anti-static cover that is grounded to the table.

No plastic sheeting should be permitted on the table. Several ICs on a board can be effectively destroyed by casually laying it on a mylar page protector, for example. All plastic materials, not only sheet plastic, should be avoided, if possible. For example, tools with wooden handles are preferable to tools with plastic handles.

The table should have a wrist strap, grounded to the table itself, for use by anyone working at the work station. The wrist strap grounds your body, but not your clothing. Therefore, you should wear short sleeves. If long sleeves are worn, they should be covered with an anti-static gauntlet. Clothing that contains artificial fiber generates large static charges. Therefore, natural materials are preferred.

A wrist strap may be dangerous. When the strap is on one wrist and you contact a high voltage source with the other hand, current will flow through your body, with perhaps a fatal result. Therefore, **DO NOT USE THE WRIST STRAP WHERE THERE IS ANY CHANCE OF EXPOSURE TO HIGH VOLTAGES.** By design, there are no high voltages in the 850.

TOOLS AND SUPPLIES

You must supply your work station with the following:

- o Oscilloscope
 - Dual trace
 - Input impedance 1 MegOhm or more
 - Bandwidth 15 MHz or more
 - Sensitivity 5 v/cm or better
 - Speed (X-axis) 1 microsec/cm or better
- o Grounded soldering iron (rarely used)
- o Hand tools
- o IC Extractor
- o Spare parts (See Appendix 8)

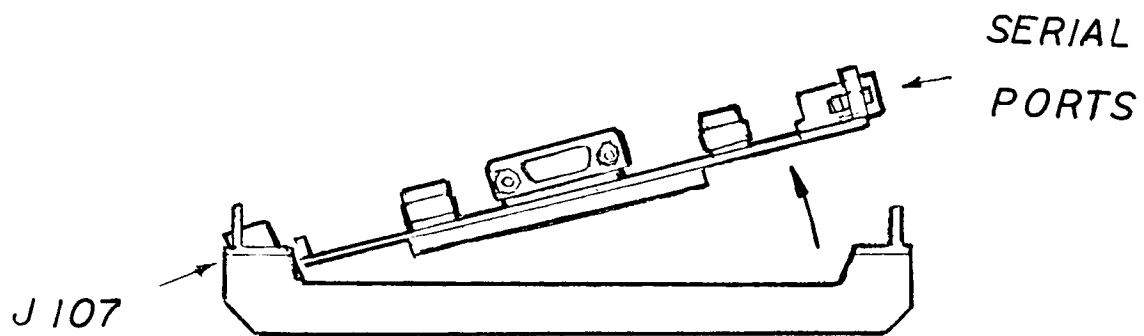

Figure 3-1. Removal of PC Board from the bottom shell.

DISASSEMBLY AND ASSEMBLY

DISASSEMBLY

To gain physical access to the PC Board of the 850, proceed as follows:

1. Turn the 850 upside down.
2. Remove the 4 screws in the base of the 850 case. Removing these screws disengages the two halves of the shell.
3. Holding the two halves of the shell together, turn the 850 right side up again. Lift off the top half of the shell.

Since the PC Board is now accessible, no further disassembly is necessary for many purposes. For example, all voltages checks can be made at this stage.

4. The PC Board is not attached to the base of the plastic shell (except by the 4 screws you have already removed), but the two parts fit snugly together. To remove the PC Board from the base of the plastic shell, separate the board from the shell at the serial port edge first. (See Figure 3-1.) You may have to bend the plastic shell very slightly, to let the PC Board clear the shell.

5. The metal RF shield obstructs access to several chips, including the the ROM, the PIAs and the microprocesor. To gain access to the ROM only, slide off the small metal window in the RF shield. To gain access to the other chips under the shield, remove the shield. To remove the shield, first straighten the metal tabs that are part of the bottom half of the shield. These tabs protrude through the PC Board and through the top half of the shield, and are twisted or bent to secure the shield to the PC Board. When you have straightened the tabs, the top half of the shield is easily lifted off.

7. There may be a serial number on a sticker on the shield, or elsewhere. **DO NOT REMOVE THE STICKER.** The number is required if the unit has to be returned to the factory.

ASSEMBLY

You may reassemble the 850 by reversing the steps described for disassembly. The only tricky step is putting back the PC Board in the plastic shell. The switch and LED will obstruct the insertion of the PC Board unless the correct procedure is followed. First position the edge of the board that has the protruding switch and LED. The board should then drop in easily. You may have to bend the shell very slightly.

PREVENTIVE MAINTENANCE

The 850 requires very little preventive maintenance.

1. Separate the shell and the PC board. Use the procedure described under "Disassembly and Assembly."
2. Clean the shell with a mild soap or detergent and a soft cloth. Most 850's have cyclolac shells, but you may encounter a shell of anodized aluminum. If the shell is damaged, replace it.
3. Inspect the PC Board
 1. Remove the RF shield (both halves).
 2. Examine the board. It should be planar, flat. There should be no visible curving of the surface or warping. Replace a board that is visibly warped.
 3. Examine the board for discoloration. There should be no visible discoloration. Discoloration is usually caused by overheating of a component. If you suspect a component of overheating, power up the board, observing the usual precautions, and determine if the component gets hot to the touch. If it does, power down, replace

the component, and check again to see if the new component gets hot to the touch. If it does, the power supply is probably out of specification (see Trouble Shooting). If your initial test reveals no overheating, the component may be overheating during operation of the 850. The overheating may be occurring in some operating modes and not others. Such a fault is very difficult to pinpoint. As a precaution in such a case, replace all suspect components.

4. Examine the board for solder splashes. Carefully remove any present.

5. Re-attach the RF shield.

4. Inspect the Connectors

1. Examine the connectors J106 and J107. Check for broken or bent pins or loss of plating. Replace as necessary.

2. Examine the connectors J101 through J105. Check for broken spring contacts inside the Delrin housing. Replace as necessary.

5. Reassemble the 850, using the procedure described under "Disassembly and Assembly".

TROUBLE SHOOTING

INTRODUCTION

This section contains trouble-shooting information. The procedures you will use depend strongly on whether the Interface Module does or does not boot, so different procedures are separated under these headings.

The information in this chapter is summarized in the Trouble-Shooting Guide at the end.

BASIC SET-UP FOR TROUBLE SHOOTING

Set up your test bench with a 400/800 with BASIC, a TV monitor and the 850.

Power on the 850 before you power on the 400/800. When you power on the 400/800, the 850 should boot.

The main distinction to note in trouble shooting is whether or not the 850 boots.

WHEN THE 850 BOOTS

The successful booting of the 850 shows that the following components are operational:

1. Power-on reset
2. 5 Volt power supply
3. Clock circuit
4. 6507 microprocessor
5. ROM. Parts of the ROM containing the instructions for reading and responding appropriately to the commands over the system I/O port, testing the local RAM, and so on, are used in the boot process. However, not all the code in the ROM is exercised during booting. Therefore, even when the 850 boots successfully, some parts of the ROM code may be faulty.
6. The buffers for the system I/O port.

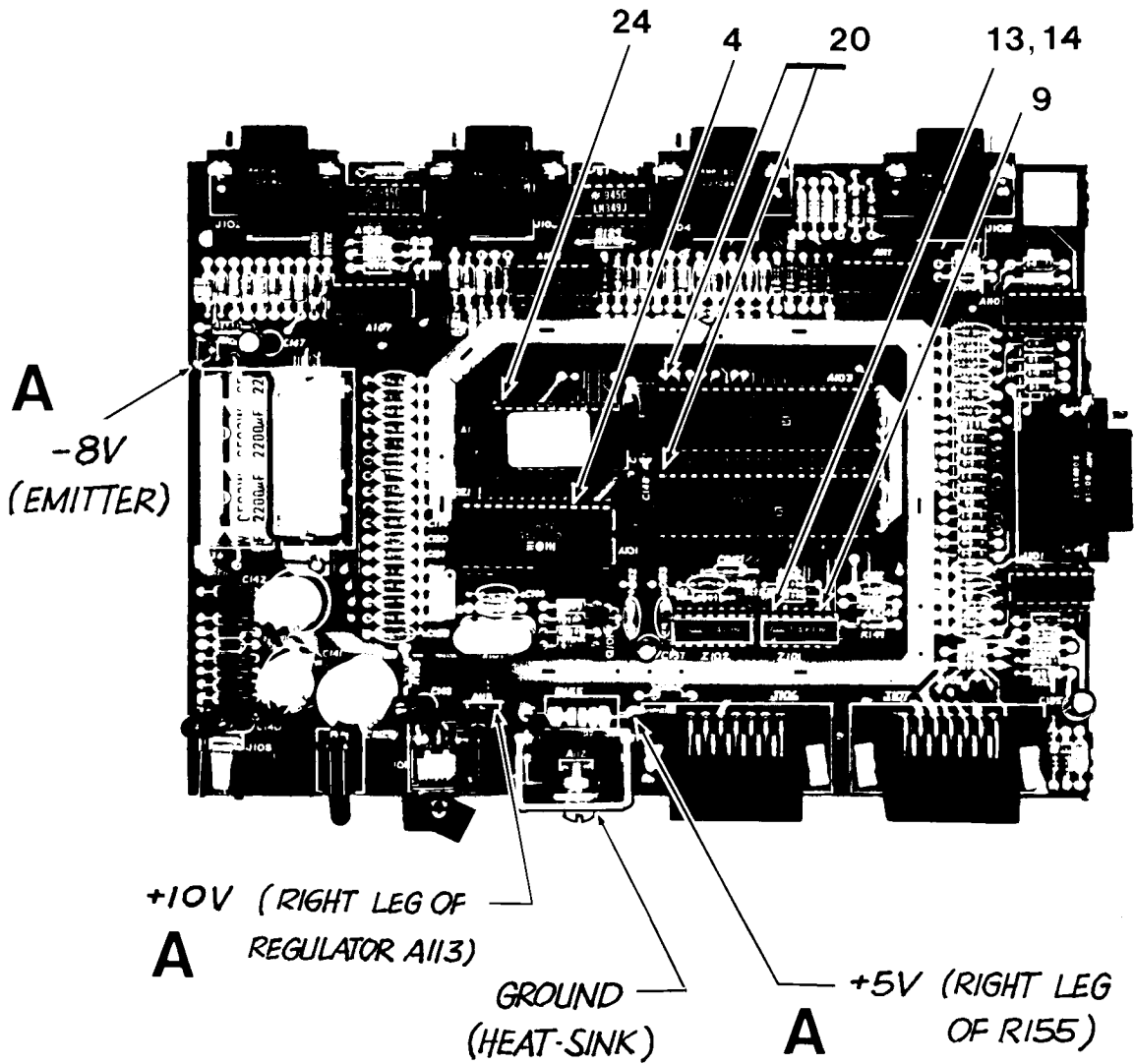

Figure 3-2. Test points for the power supply. Use the points marked "A" for a quick initial check to verify that the power supply is operational. Use the other points (with pin numbers marked) in trouble shooting for failure of the 5VDC when the 850 does not boot. See text.

Power Supply (10 VDC and -8 VDC)

Successful booting shows that 5 VDC power is sufficient, but failure of the 850 in operation may be due to failure of one or both of the other DC power supplies (10 VDC and -8 VDC).

The Clock Circuit operates from 10 VDC, so it would seem that a successful boot shows that the 10 VDC power supply is all right. That inference is invalid, however, since the clock circuit may operate over a wide range of power supply voltage. At voltages lower than 10 V, the Clock Circuit becomes more and more unreliable; oscillations may become erratic, for example, producing intermittent apparent framing errors when the 850 reads data coming from the console. Also, a problem with the power supply may develop after the 850 boots, so it is not strictly true that successful booting should completely eliminate from consideration the possibility of a faulty 5 VDC supply. The same reasoning applies to the 10 VDC supply.

When the 10 VDC or -8 VDC is out of spec, the serial ports may operate satisfactorily with some peripherals and not others, or the serial ports may operate with intermittent errors.

Figure 3-2 shows convenient test points for checking DC voltages.

If the voltages are not within specifications (+ or - 5%), you should bring them into specification. Consult the description of the power supply in Appendix 3. In tracing a failure, check voltages successively back from the output to the power input at J108.

The 10 VDC is used only for the Clock Circuit and the Serial Port buffers. If we can eliminate the Clock Circuit as the problem, we can concentrate on the Serial Port buffers. A hot regulator (A113) combined with an out-of-spec low voltage, suggests loading by the buffers. To check this:

1. Switch off power and remove I/O cables.
2. Remove A105
3. Turn on power and check voltage of (nominal) 10 VDC supply. If the voltage is within specs, A105 is identified as the component that is excessively loading the 10 VDC supply. Then replace A105.

4. If still out of spec, turn off power and remove A106.
5. Turn on power and check the voltage of the (nominal) 10 VDC supply. If the supply is not still out of spec, then A106 is identified as the source of excessive loading, and you should replace it. (It may be necessary to replace both A105 and A106).

If the voltage remains out of spec when A105 and A106 are removed, the power supply itself is probably defective, and you must proceed to isolate the fault on the board rather than by replacement of plug-in components.

Local RAM

The local RAM is contained in the two PIA chips (6532s). Each chip has 128 bytes of RAM. The local RAM constitutes the data buffer of the 850. In this context, "buffer" means temporary store. Data transmitted through the 850 are temporarily stored in the buffer.

Local RAM is tested as part of the boot process. The Printer Port is used to indicate the result of the RAM test. If the RAM test is passed, 00 is output to the Printer Port. Since this is the null character, there will be no effect on an attached, powered printer. However, if the RAM test is failed, a printable byte is sent to the Printer Port, as follows:

AA hex indicates that the RAM in A104 did not pass the RAM test

2A hex indicates that the RAM in A103 did not pass the RAM test

Both these bytes (AA and 2A) would result in the printing of an asterisk on the ATARI 825 Printer, if the appropriate strobes were also sent. Since the strobes are not sent after the RAM test, your Printer will not, as a rule, give any indication that the RAM test was failed. To verify that the RAM test failed, you should monitor one of the Printer Port bits (pins 3 or 5 or 7) with your oscilloscope. On the other hand, if the printer does print something during the boot process, a failure in the local RAM is indicated.

Port Buffers

If the fault you are correcting concerns I/O through a serial port, replace A105 and/or A106 and/or A107 and/or A108 and test

the faulty port with the program given in section Appendix 7. Note that output from the 850 uses 10 VDC and -8VDC, whereas input does not use these power supplies. Consequently, when you isolate a fault to output, you should suspect these power supplies.

If you have checked A105, A106, A107 and A108 and the I/O fault persists, it may be due to breaks in traces or improper contact between traces due to warping or crystal growth since manufacture. Check these possibilities.

If the problem with the Port Buffers persists when all these possible causes have been eliminated, the source of the problem lies below the level of replaceable parts. In that case, the PC Board should be returned to the factory for repair.

If the fault concerns the buffers on output to the Printer Port, replace A110 and/or A111. In this case, also, a persistent fault may be due to breaks or improper contacting of traces.

Testing Each Port

You can test each port with the Port Test Program given in Appendix 7. You need only basic equipment (TV or monitor, 400 or 800 console with a BASIC cartridge, and the 850 itself).

Proceed as follows:

1. Power up the system, 850 first, then the 400/800 console.
2. Wait for READY on the screen, which shows that the 850 has booted.
3. Connect pins 3 and 4 of the port to be tested.
4. Enter on the keyboard the program given in Appendix 7.
5. RUN the program.
6. Inputs and outputs are both shown on the screen. They should be identical. Compare the inputs and outputs.

7. If you see errors (mismatches) try a lower Baud. Intrusion of errors at higher Bauds shows that the serial port buffer is out of spec. In that case, replace the buffer chips of the port.

Checking Address Lines

A great variety of faults might be caused by breaking or contacting of address lines, whether or not the 850 boots. This possible source of malfunction should be checked only when all components have been checked without finding the source of the fault. See Appendix 9.

WHEN THE 850 DOES NOT BOOT

When the 850 fails to boot, the fault may lie with the power supply (5 VDC), the clock circuit, the power-on reset function, the microprocessor, the ROM, or the System I/O Port. Other possible causes are not likely, or will come to light when examining those possibilities mentioned.

Power Supply (5 VDC)

When the 850 fails to boot, it is probably most efficient to check the 5 VDC first. If the power LED does not light, it is likely (though not necessary) that the power supply is faulty. However, the fact that the LED lights does not prove that the 5 VDC power supply is not faulty.

1. Remove the top of the shell of the 850, exposing the PC Board. (See Disassembly and Assembly.) Remove the top half of the RF shield.
2. Check the 5 VDC at the points shown in Figure 3-2. If any of these test points show a voltage out of spec (outside the range 4.75--5.25 VDC, or with ripple of more than 0.1 VDC), the 5 VDC power supply may be defective.
3. If some test points show zero volts, look for broken traces.
4. If some test points show a low voltage, check for excessive loading.

5. Check the heat sink on A112. Poor attachment of the heat sink permits A112 to overheat, affecting regulation.

6. If neither loading nor broken traces nor a hot regulator may account for the deviation of the 5 VDC from specifications, further analysis of the 5 VDC power supply is called for. Refer to Appendix 3.

Clock Circuit

Failure to boot may be due to failure of the Clock Circuit. You need your oscilloscope to check the Clock Circuit. See the section on Tools and Supplies for specifications.

To check the Clock Circuit, you also need to have access to the PC Board and to the chips under the RF shield. Assuming you have checked the 5 VDC, you will have the 850's PC Board exposed. Disconnect the Power Adapter, remove the PC Board and take off the top of the RF shield, if you have not already done so. Now plug in the Power Adapter again and turn on power.

Use your oscilloscope probe to check the Clock Circuit at Z102, pin 13. The clock rate is approximately 1 MHz. A 1 MHz signal at pin 13 shows that the Clock Circuit is operating properly. Now compare the signals at pins 13 and 12. The signal at pin 13 is unloaded. If there is a clean square wave at pin 13 and a reduced or distorted wave at pin 12, a loading of the output is indicated. In that case, turn off the power, remove A101 and recheck pin 12 of Z102. If pin 12 is still loaded, check C146, R161 and CR121. If these components are not faulty, Z102 itself is defective. In that case, replace Z102 and recheck the comparison of the signal at pins 13 and 12 of Z102.

If the loading of pin 12 disappears when A101 is removed, the source of the loading is the A101 chip. If that is the case, replace the A101 chip (the microprocessor) and re-check the comparison of the clock pulses at pins 13 and 12.

It is also possible that your oscilloscope probe itself adds sufficient loading to distort the waveform, or even to stop oscillations completely.

You may find that the outputs of Z102A (pins 12 and 13) are not following the input (pin 3). This occurs when the input voltage drops to about 7 volts. If the flipflop is not following the input and the voltage at pin 3 is not the full supply voltage (10 V), replace X101. It is also possible under these circumstances that some of the discrete components in the oscillator circuit have failed, especially C144 or C145.

The 850 uses the clock frequency in serializing and de-serializing data sent to and received from the 400/800. Therefore, if the clock frequency is not exactly 1.1084045 MHz (equivalent to 902 ns per cycle, and the discrepancy is large enough, the 850 will introduce transmission errors. Failure to boot may be due to this type of error.

Power-On Reset

Failure to boot may be due to failure of power-on reset.

You need an oscilloscope to check power-on reset. Input impedance should be at least 1 Megohm.

First verify that Vcc READY is coming in to the system I/O port when the 400/800 is powered on.

This will show that failure of the power-on reset is attributable to the circuit itself rather than the absence of its input (Vcc READY).

Test the power-on reset circuit with the system I/O port connected to the 400/800. For diagnostic purposes, the power-on reset circuit should be checked when the 850 is powered on before the 400/800.

With that power-on sequence, the 850 should boot.

Monitor the power-on reset signal at A101, pin 1 or Z101, pin 10 or at R149.

When the 400/800 is powered on, pin 1 of A101 should stay low for about 200 ms then go high (5 VDC) and stay high as long as the power is on.

If the power-on reset, just described, does not occur, turn off power to the 850 and remove Z101.

Now you have to check the 850 by rigging a power-on reset pulse. Hold pin 1 of A101 low, turn on power, then pull pin 1 high, starting the microprocessor.

Starting the microprocessor in this way (followed by a successful boot) verifies that the power-on reset circuit is faulty.

Repair the power-on reset circuit with the following steps:

1. Replace Z101. Check the power on reset function again.
2. Replace A109. Check the power-on reset function again.
3. Check the discrete components below and replace as necessary:

CR110	C129	R150
CR123	C135	R151
	C153	R166
		R167
		R168

Microprocessor

Failure to boot may be due to failure of the microprocessor.

Before suspecting the microprocessor itself, you should verify that the microprocessor is being powered and is receiving proper clock pulses and power-on reset pulse.

To verify that the microprocessor is operating, you need to check the address lines with your oscilloscope. It is best to check the address pins on the chip (A101). To gain access to these you must expose the PC Board and remove the RF shield. If the microprocessor is operating, the least significant address bit will be pulsing at approximately 500 kHz. The pulse train will not be regular--pulses will be of different widths. Check with your oscilloscope probe on pin 5 of A101.

If pin 5 is not pulsing, turn off power to the 850, replace A101 and verify that the replacement is satisfactory by checking pin 5.

The failure of the microprocessor may be due to loss of the $\phi 2$ output from the microprocessor to the PIAs. To check this possibility, look at pin 20 of A101 with your oscilloscope probe. Pin 20 should pulse at the same frequency as the clock to the microprocessor (approximately 1.1 MHz). The clock input and the $\phi 2$ output are 180 degrees out of phase.

ROM

Failure to boot may be due to defects in the ROM (A102). Check this possibility by replacing the ROM.

Local RAM

Failure to boot may be due to defects in the local RAM in the 6532s.

The local RAM is tested as part of the boot process (see Local RAM section under WHEN THE 850 BOOTS). Generally, a failure of local RAM need not prevent booting, but if the failure is extensive or in a critical area, the 850 will not boot. If the 850 cannot retain information necessary for execution of commands, booting will be impossible.

To check the local RAM, monitor pins 3, 5 or 7 of J101 during attempted boot. A pulse on any of these pins indicates defective local RAM. If the local RAM is determined to be defective, replace A103 and/or A104.

System I/O Port Buffer

Failure to boot may be due to failure of communication through the System I/O Port, in one direction or the other, or both.

The lines between the 850 and the System I/O Port are buffered with transistors and an operational amplifier on the Vcc READY input.

If no fault is found in the power supply, the clock circuit, the power-on reset function or the microprocessor, you should check the possibility of a defect in the System I/O Port buffer. Use your oscilloscope to determine if the Command Frame data are getting through transistor A109A to pin 8 of A104, and if an ACK signal from pin 13 of A104 is getting through transistors A109B and Q103.

The Vcc READY signal may not be resetting A101, etc., because of a defective buffer, namely, Z101D. However, Z101 is checked in the process of checking the power-on reset function.

You might be inclined to check the System I/O Port as soon as you determined that the 850 does not boot, rather than using the sequence recommended here. However, these trouble shooting procedures assume that you are using a perfectly serviceable 400/800 console and I/O cables, so that you can be sure there is no I/O fault between J106 (J107) and the 400/800 console. In that case, the small probability of an I/O failure being due to defects of A106, A108 or A104 suggests that other possibilities be examined first.

Grounds

Failure to boot (and various other malfunctions) can be caused by improper grounding. The range of symptoms caused by improper grounding is so wide that it is not possible to recommend a procedure

for detecting this fault. However, any time you encounter a very noisy signal, you should strongly suspect poor grounding and you should continue to explore until you find the poor ground connection or until you can rule out that cause.

PRINTER PORT

If you have traced a malfunction to the Printer Port, consider the following:

- The handshaking signals from the Printer must be correct. The FAULT* line must be held high to signify to the 850 that a Printer is connected. The FAULT* line is pin 12 of J101. To make sure that FAULT* is high (5 v), measure it. If the FAULT* line coming from the printer is not high, the problem is with the printer. This should not occur with an ATARI 825 Printer. An apparent fault of this nature might be due to a defect with the cable to the printer, rather than the printer itself. (The asterisk in "FAULT*" is the convention used here for an active-low signal.)

If the printer is sending the correct FAULT* signal, it may not be propagating through A110, or A104 may be defective. You can check these possibilities by chip replacement.

When the Printer is printing, the BUSY line (pin 13 of J101) must be held high. When the BUSY line is high the 850 sends no more data to the printer. If the BUSY line is not held high, successive transmissions of the 850 to the printer may interfere with each other, producing garbled or missing data. If that is the symptom, the fault is in the printer or in A110 or in A104. First check the printer to verify that an appropriate signal is being sent to pin 13 of J101. Then verify that the BUSY signal is reaching A110 pin 8. If these checks fail to reveal the fault, replace A104.

- The printer may fail to print exactly the data sent to the 850. For example, the printer may print certain lower case characters as upper case characters, or may show this fault at some times and not at others. This kind of malfunction is due to dropping of bits in the buffer or in the 6532 (A103). Therefore, when you encounter this fault, first replace A110 and/or A111. If the fault persists, replace A103.

- If Printer Port problems persist even when you are satisfied that the buffers (A108, A110 and A111) and the PIAs (A103 and A104) are not responsible, the fault may lie in the ROM. Under certain operating conditions, or because of ageing changes, the ROM may exhibit small errors. While this is unlikely, it is easy to check by replacement of the ROM.
- Improper loading of address lines on the address bus may produce errors in printing. For procedures to check the address lines, see Appendix 9.

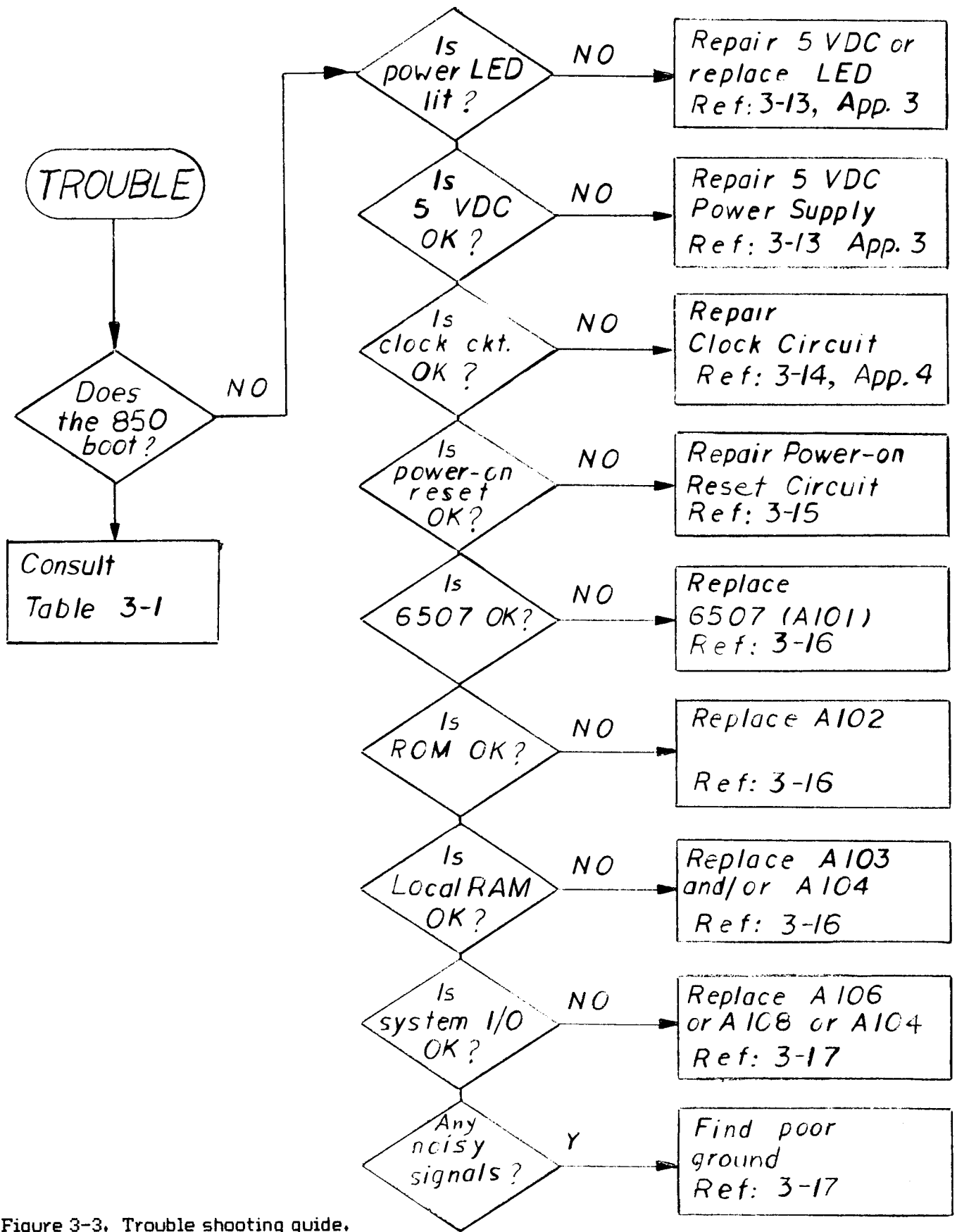

Figure 3-3. Trouble shooting guide.

Table 3-1. TROUBLE-SHOOTING WHEN THE 850 BOOTS

OBSERVED FAULT	ACTION OR PROBABLE FAULT	REFERENCE (PAGE)
No I/O instructions executed.	Check Power Supply (10 VDC and -8 VDC)	3-10
I/O instructions executed with errors.	Check all serial ports	App. 7
I/O instructions executed with errors on all serial ports.	Check Power Supply	App. 3
I/O instructions executed with errors on some serial ports, not all.	Buffers on affected ports, A105, A106, A107, A108	3-12 3-17
Printer prints during boot.	Local RAM. Replace A103 or A104	3-11
Printer prints erratically.	Buffers A103, A104	3-18
Printer does not print.	FAULT* not high, BUSY not low Bad cable	3-18 App. 2

APPENDIX 1

SYSTEM I/O BUS PROTOCOL FOR THE 850

All I/O processes are initiated from the 400/800 Operating System. The Interface Module, like all peripherals, places data on the System I/O bus only in response to commands from the 400/800. The I/O process includes error-checking routines and the current process is aborted when any error is detected.

A bus operation consists of the following elements:

Command Frame from the 400/800

Acknowledgement (ACK) from the peripheral

Data Frame (if any) to or from the peripheral, according to Command in Command Frame

Acknowledgement (DONE) from the peripheral

Command Frame

The Command Frame consists of five bytes sent from the 400/800 while the COMMAND line is held low.

These bytes have the following meanings:

Byte 1 (sent first) -- Device identifier. R1 through R4 are 50 through 53 hex, respectively.
Printer port is 40 hex.

Byte 2 -- Command.

Disk simulation, at power-on time only

STATUS	53
READ	52

At other times

Printer port:

STATUS	53
WRITE	57

RS232:

STATUS	53
TEST	20
BOOT	21
DOWNLOAD	26
POLL	3F
CONTROL	41
SET BAUD	42
WRITE	57
START CONC	58

Bytes 3 and 4 -- These bytes are used in ways that differ according to the the particular peripheral being addressed. In the case of commands for the Interface Module, bytes 3 and 4 give various specifics, such as Baud and word size.

Byte 5 -- Checksum. This is the sum, with end-around carries, of the first four bytes.

Command Frame Acknowledgement

The peripheral addressed in the Command Frame should acknowledge by sending 41 hex over the bus. The Interface Module, like all peripherals, checks the appropriateness of the command and the correctness of the checksum. If there is any error, an acknowledgement is not returned.

Data Frame

When a data transfer is called for in the command, data are sent over the bus. The contents of the Data Frame depend on the command, as shown below.

Disk simulation, at power-on time only

STATUS 4 (in)
READ 128 bytes of data and a checksum (in)

At other times

Printer port:

STATUS 2 (in)
WRITE 40 bytes of data and a checksum (out)

RS232:

STATUS 2 (in)
TEST varies (out)
BOOT approx. 300 bytes (in)
DOWNLOAD large data transfer (in)
POLL 12 (in), or no response from the polled peripheral
CONTROL 0 (out)
SET BAUD 0 (out)
WRITE 64 bytes of data (out)
START CONC 9 (in). This is folowed by an indefinite number of bytes, in or out, comprising the con-current data. These data are sent without the final checksum and the usual command frame.

Acknowledgement (DONE)

The Interface Module, like other peripherals, sends 43 hex over the bus when the operation commanded is complete.

APPENDIX 2

NOTE ON CABLES

After many insertions an I/O cable may become defective through loss of plating or metal fatigue or corrosion. Under these circumstances, rather than failing completely, the cable becomes unreliable.

You should be meticulous about cables that you use in maintenance and trouble shooting. Make sure that cables used in testing the 850 (and any other equipment for that matter) are in good condition. Examine cables for loss of plating in the connector. Discard any cable that shows evidence of loss of plating.

Periodically check the DC resistance of cables. The resistance of each conductor should not exceed 0.03 ohms. Problems may not occur so long as resistance is below approximately 2 ohms. However, a cable with a conductor having resistance of more than 0.03 ohms should be discarded.

Pins of J106 and J107 may also become defective through normal wear and tear. You should examine these for bending, loss of plating or corrosion, as mentioned in the Preventive Maintenance section. However, do not neglect the similar examination of the System I/O Port connector in the 400/800 console.

To be quite certain that there are no problems traceable to the I/O cable, you should connect J106 or J107 with the System I/O Port of the 400/800 and measure the resistance between the connectors.

The resistance should not exceed 0.03 ohms.

APPENDIX 3

POWER SUPPLY

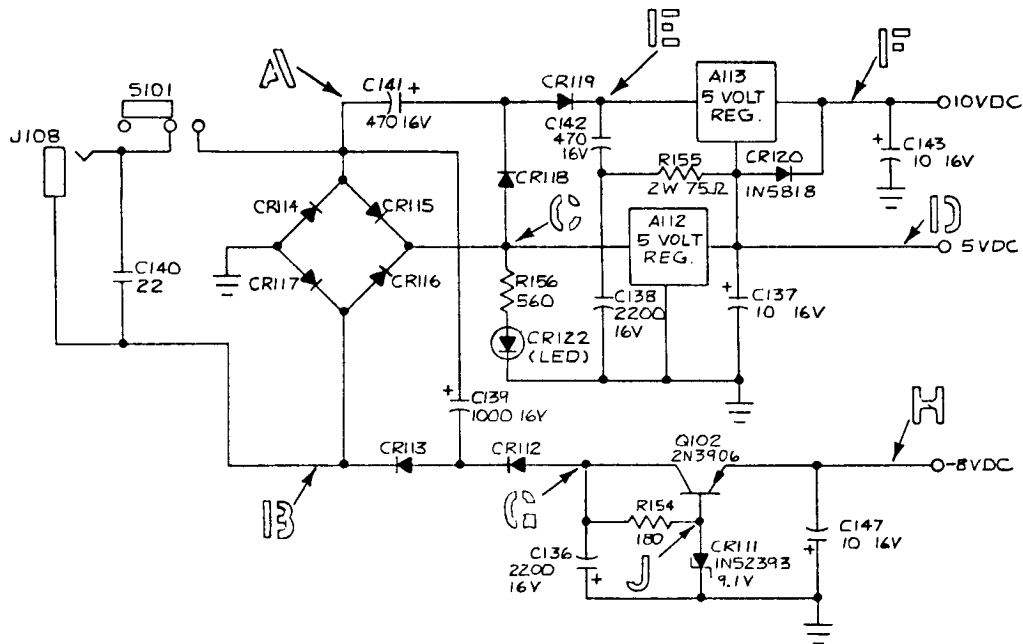

Figure A3-1. Schematic of the Interface Module power supply. All capacitor values are in uF. All diodes are 1N4001, except where marked. Test points, (A, B, etc.) are referred to in the circuit description and their positions on the PC Board are shown in Figure A3-2.

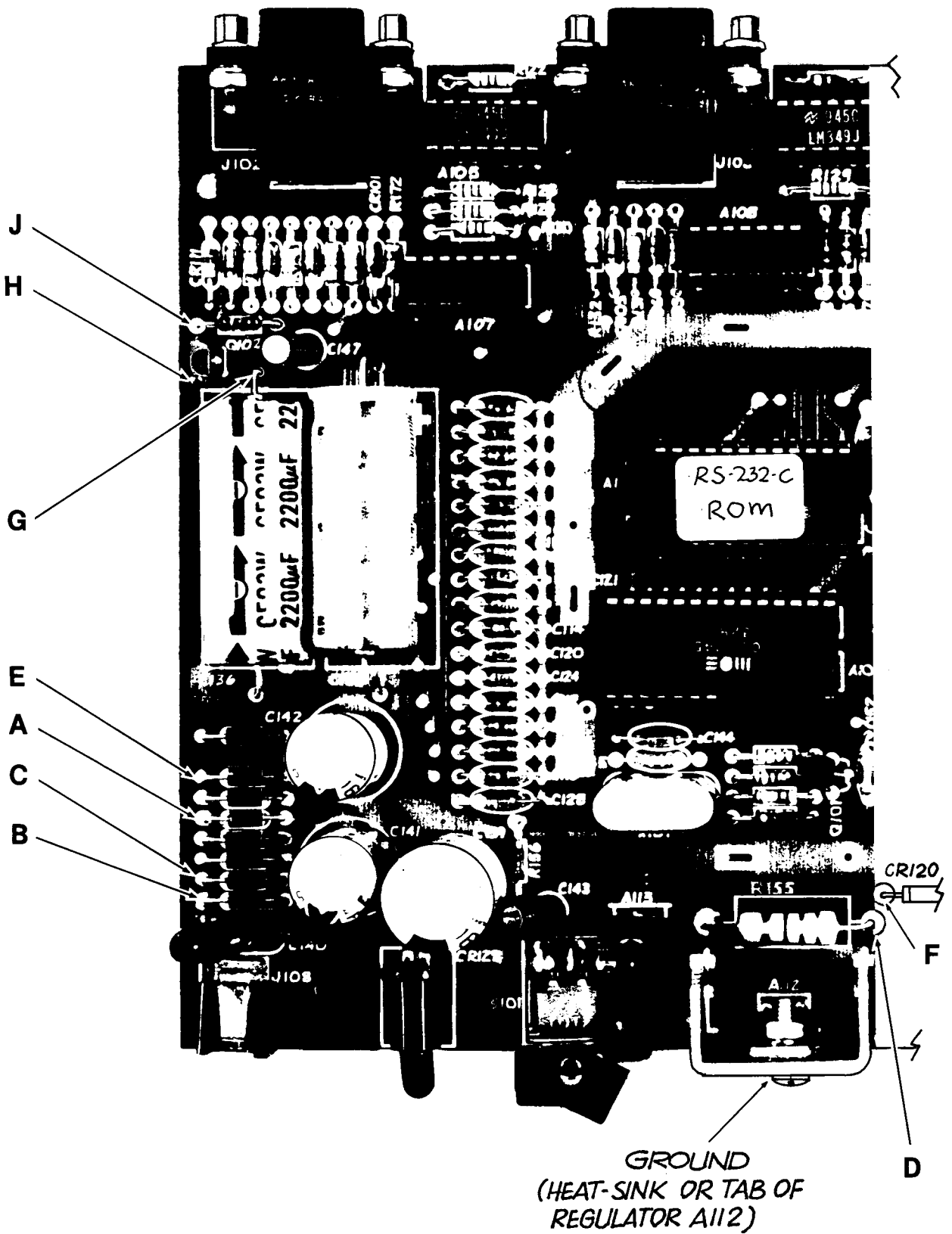

Figure A3-2. Test points for trouble shooting the power supply. See text and Figure A3-1.

POWER SUPPLY

Power for the 850 comes 110-125 VAC, which is first converted to 9 VAC then, on the 850 PC Board, to 5 VDC, 10 VDC and -8 VDC.

110-125 VAC is converted to 9VAC by the ATARI Power Adaptor (Part No. CA014748). The 9 VAC is supplied to the 850 through J108. The AC voltage is full-wave rectified (CR114 through CR117) and regulated by the power-conversion circuits in the 850. The 5 VDC is output from a 5 Volt regulator (A112). The 10 VDC is output from a second, cascaded 5 Volt regulator (A113). The -8 VDC is output from a Zener-regulated pass transistor (Q102).

5 VDC is supplied to the microprocessor, the ROM, the Peripheral Interface Adaptor (PIA) and the linear circuits and buffers.

10 VDC and -8 VDC are supplied to the linear circuits and buffers. 10 VDC is also supplied to the clock circuit.

Figure A3-1 is a schematic of the on-board power supply, and Figure A3-2 represents the PC Board. The various test points referred to here are indicated in these Figures.

In trouble-shooting the power supply in general, check progressively from J106. If you need to check only the -8 VDC supply, go directly to step 6 after step 2.

1. Verify that AB reads 9-10 VAC RMS (approximately 20-25 volts peak to peak), with 120 VAC input to the Power Adapter.
2. Measure the voltage at C. C should be a full-wave rectified source without significant loss of peak value with respect to AB. If this is not the case, one or more of the following diodes is defective: CR114, CR115, CR116, CR117.
3. Measure the voltage at D. If the voltage is outside the range 4.75 - 5.25 VDC (with respect to ground), then regulator A112 is defective, or its heat sink is loose.

4. Measure the voltage at E. It should be approximately 18.5 VDC, derived from the full-wave rectified 10 volts plus half-wave rectified 10 volts. If the voltage is below 18 VDC, then one or more of the following is defective: C142, CR118, CR119.

Measure the voltage at F. If the voltage is outside the range 9.5 – 10.5 VDC, then regulator A113 is defective.

6. Measure the voltage at G. It should be half-wave rectified 9 volts. If the voltage is below 8.8 volts, one or more of the following is defective: C136, C139, CR112, CR113.

9. Ensure that the -8 Volt supply is not being loaded. Measure the voltage at H. It should be at least 8.25 Volts negative. If it is less than 8.25 Volts, one or more of the following is defective: C147, CR111, Q102. (R154 is unlikely to be defective.)

The voltage at J should be the value of the Zener CR111 (8.7 – 9.1 VDC). If the waveform is the same at G and J, the Zener CR111 is defective.

You may be able to induce some ripple on the -8 VDC by loading the supply by operating simultaneously all serial ports and the 20 mA current loops. Small loss of regulation under these conditions is not a defect.

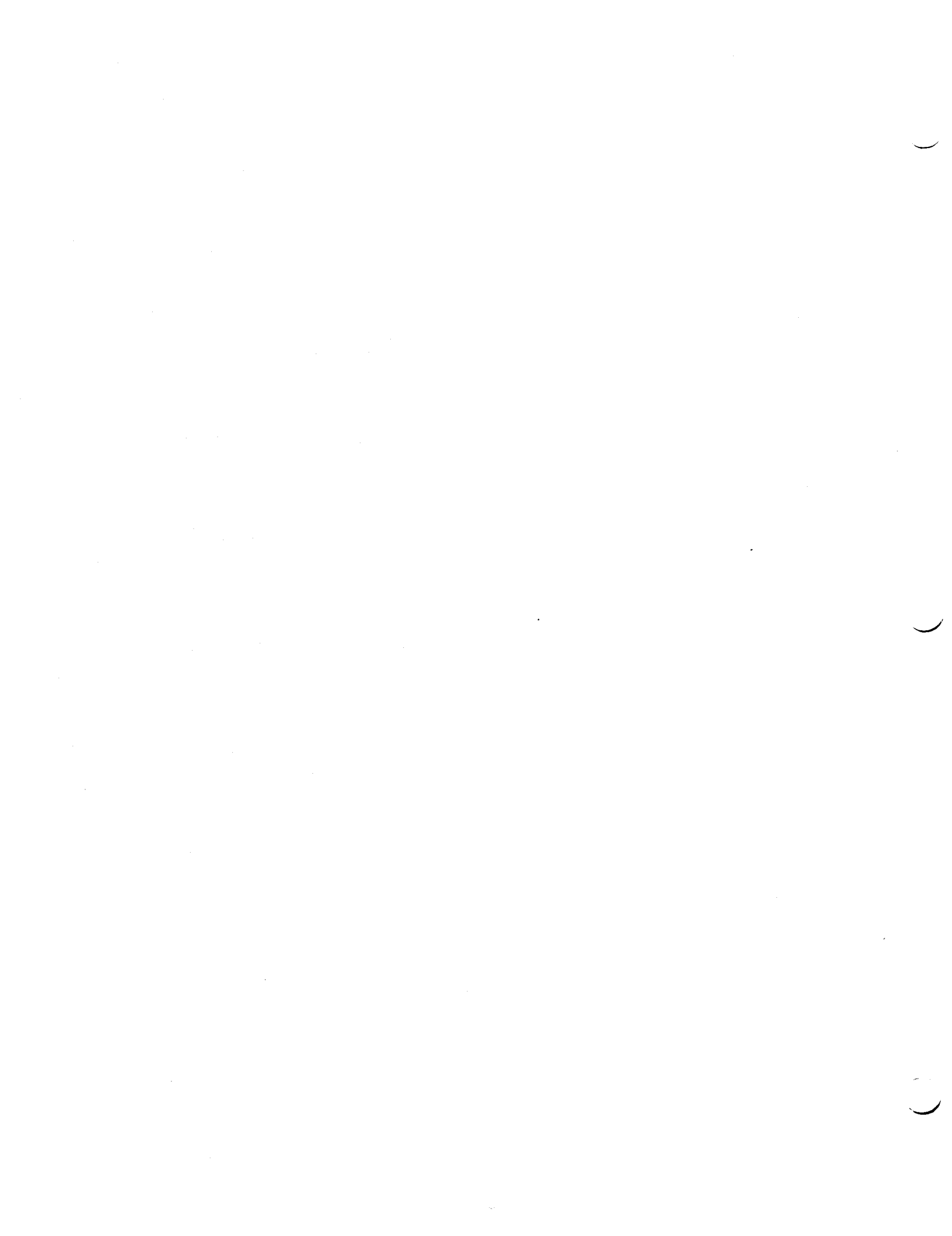

APPENDIX 4

CLOCK CIRCUIT

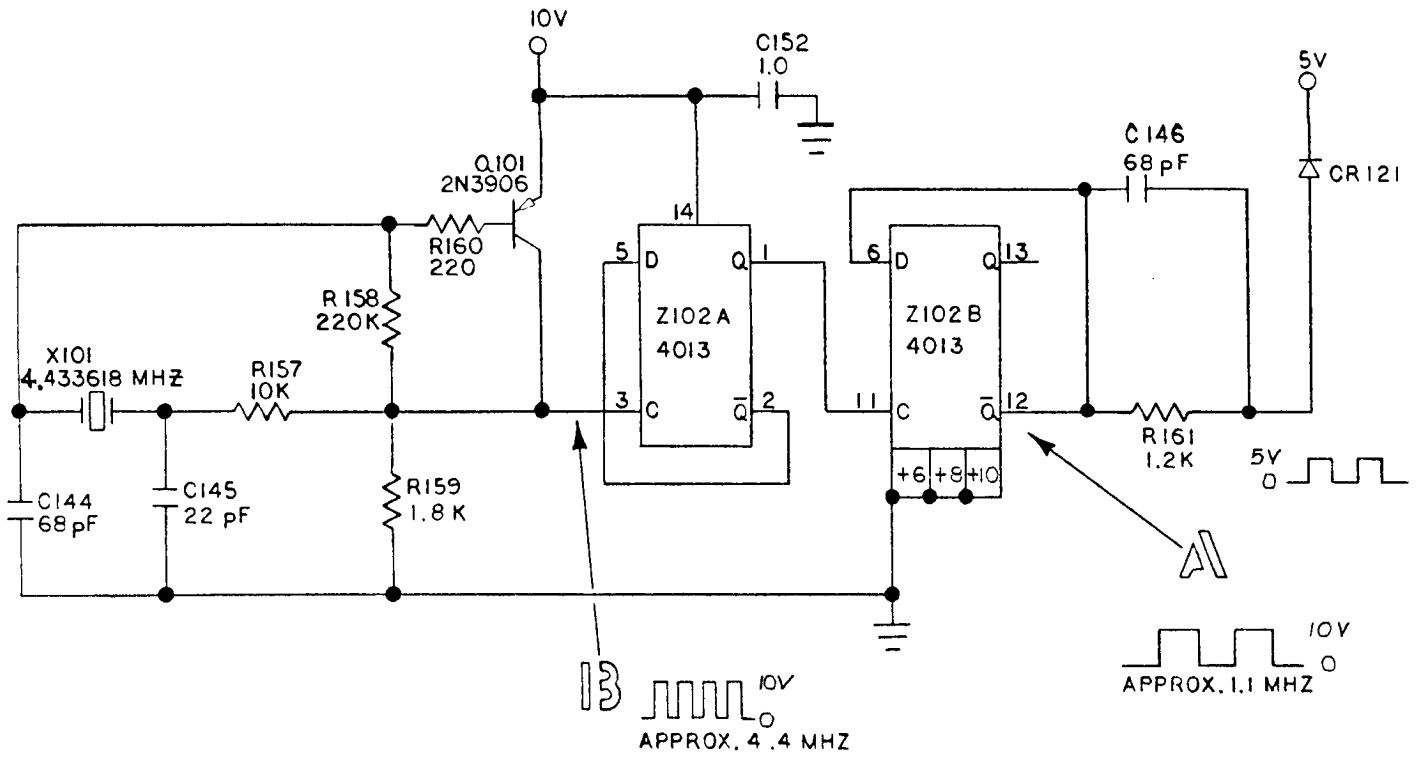

Figure A4-1. Schematic of the Interface Module clock circuit. The position of A and B on the PC Board are shown in Figure A4-2.

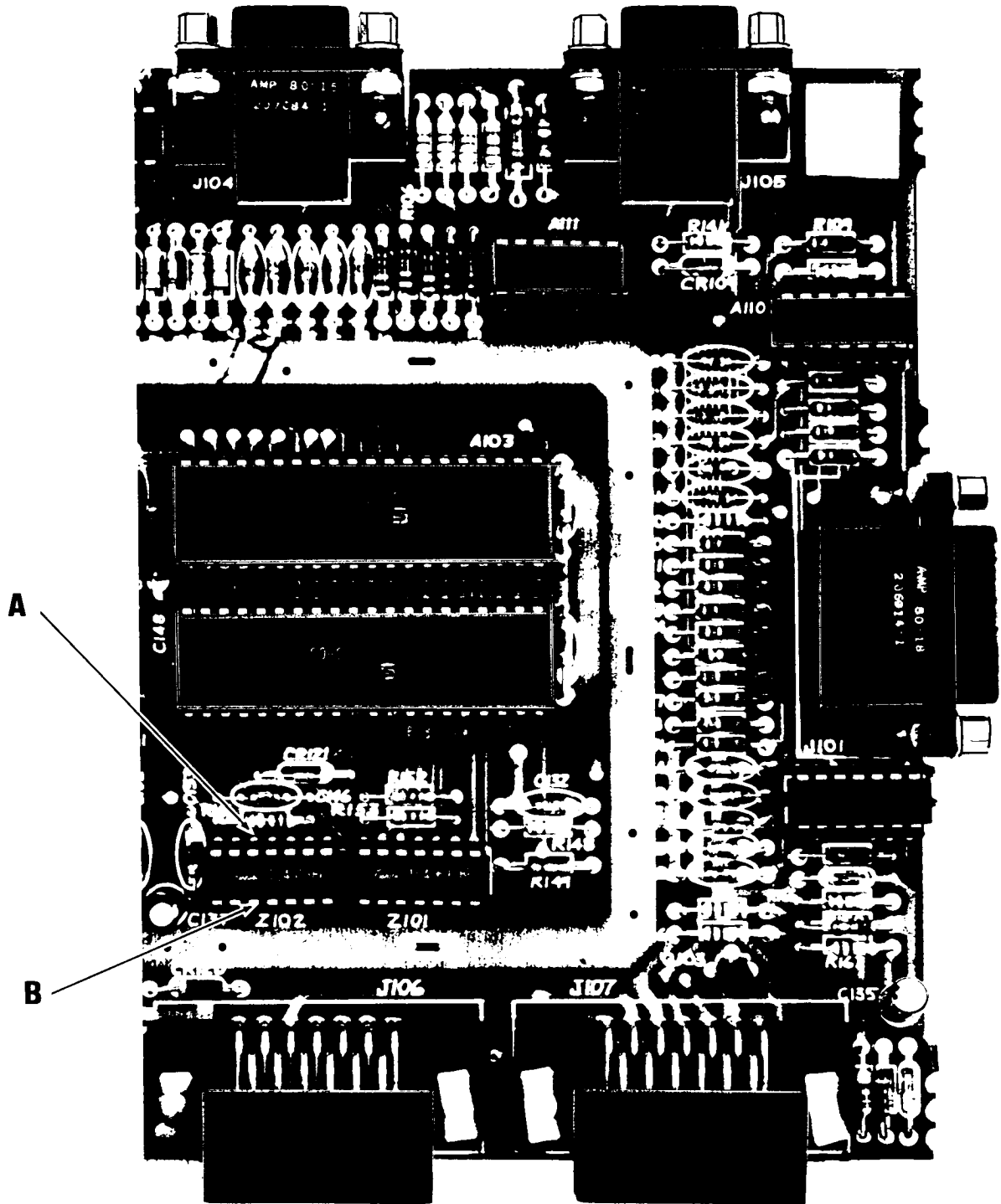

Figure A4-2. Test points for trouble shooting the clock circuit. See text and Figure A4-1.

CLOCK

The clock signal is derived from a 4.433618 MHz crystal in association with appropriate shaping and switching components.

Two D-type flip-flops are connected in a divide-by-four configuration, controlled by the clock input. The clock input comes from the collector of a PNP transistor (Q101). The frequency of pulses in the Q101 collector is driven at the frequency of the crystal X101. The output of the divide-by-four circuit is a pulse train at 1.1084045 MHz. The clock pulses out of pin 12 of Z102B go through an RC network and are applied only to pin 27 of the 6507 microprocessor.

An excessive loading of the oscillating circuit will stop oscillations. This may occur when taking measurements with an oscilloscope. Always use high impedance probes.

APPENDIX 5

PERIPHERAL INTERFACE ADAPTER (6532)

PERIPHERAL INTERFACE ADAPTER (6532)

- Address Decode and Chip Select Logic
- Data Direction Register
- Buffers
- RAM
- Programmable Interval Timer
- Interrupt Register

DIFFERENCES BETWEEN PORTS A AND B

- Only Port A can generate an Interrupt
- Port B Buffers can source Higher Current
- Read Operations Differ

PROGRAMMABLE INTERVAL TIMER

Figure A5-1. SIMPLIFIED BLOCK DIAGRAM OF THE 6532.

Figure A5-2. PIN ASSIGNMENTS OF THE 6532

Figure A5-3. BLOCK DIAGRAM OF THE PROGRAMMABLE INTERVAL TIMER

Table A5-1. ADDRESS CODING

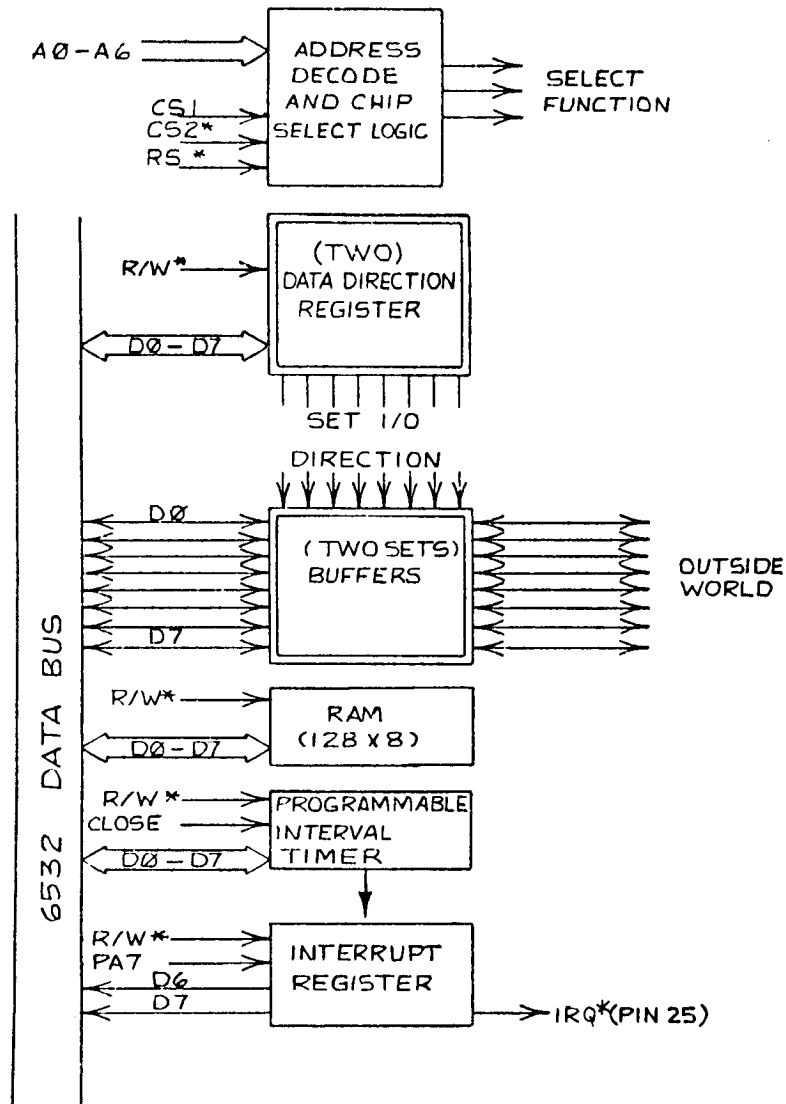

Figure A5-1. Simplified block diagram of the 6532 PIA. This diagram shows only the principal features. The 6532 has two 8-bit ports, almost identical; the diagram shows only one port, and indicates which blocks are duplicated in the second port.

Vss	1 ●	40	Address bit 6
Address bit 5	2	39	Clock input
Address bit 4	3	38	Chip Select CS1
Address bit 3	4	37	Chip Select CS2*
Address bit 2	5	36	RAM Select RS*
Address bit 1	6	35	Read or Write R/W*
Address bit 0	7	34	Reset input RES*
Port A bit 0	8	33	Data bit 0
Port A bit 1	9	32	Data bit 1
Port A bit 2	10	31	Data bit 2
Port A bit 3	11	30	Data bit 3
Port A bit 4	12	29	Data bit 4
Port A bit 5	13	28	Data bit 5
Port A bit 6	14	27	Data bit 6
Port A bit 7	15	26	Data bit 7
Port B bit 7	16	25	Interrupt output IRQ*
Port B bit 6	17	24	Port B bit 0
Port B bit 5	18	23	Port B bit 1
Port B bit 4	19	22	Port B bit 2
Vcc (5 VDC)	20	21	Port B bit 3

Figure A5-2. Pin assignments of the 6532.

Table A5-1. ADDRESS CODING

Function	RS*	R/W*	A4	A3	A2	A1	A0
Write RAM	0	0	r	r	r	r	r
Read RAM	0	1	r	r	r	r	r
Set Port A DDR	1	0	x	x	0	0	1
Read Port A DDR	1	1	x	x	0	0	1
Set PORT B DDR	1	0	x	x	0	1	1
Read Port B DDR	1	1	x	x	0	1	1
Write Port A	1	0	x	x	0	0	0
Read Port A	1	1	x	x	0	0	0
Write Port B	1	0	x	x	0	1	0
Read Port B	1	1	x	x	0	1	0
Set Timer ratio							
1:1	1	0	1	a	1	0	0
1:8	1	0	1	a	1	0	1
1:64	1	0	1	a	1	1	0
1:1024	1	0	1	a	1	1	1
Read Timer	1	1	x	a	1	x	0
Read Interrupt Register	1	1	x	x	1	x	1
Set Edge Detect	1	0	0	x	1	b	c

Notes:

r - RAM addresses. Address bits A5 and A6, being irrelevant to the remainder, are not shown in this table. In addition, to address RAM, CS1 must be high and CS2* must be low.

x - Don't care

a - 0 disables interrupt from timer to IRQ*; 1 enables interrupt.

b - 0 disables interrupt from Port A bit 7 to IRQ*; 1 enables interrupt.

c - 0 sets Port A bit 7 for negative-going edge detection, 1 for positive-going.

PERIPHERAL INTERFACE ADAPTER (6532)

The information in the Appendix is included for reference purposes and to permit insight into the operation of the Interface Module. The operation of the 6532 is described in general and its particular operation in the Interface Module is not described.

The 6532 comprises two bi-directional, 8-bit ports, 128 bytes of RAM, and a programmable interval timer producing a maskable interrupt. (The maskable interrupt is not used by the 850.)

The 6532 is a 40-pin device. Pin numbers and descriptions are given in Figure A5-2. A simplified block diagram is given in Figure A5-1. In these diagrams and in the following descriptions, an active-low signal is indicated by an asterisk. For example, the Reset pin is effective when low, and is therefore named RES*.

A general description of the elements of Figure A5-1 follows.

Address Decode and Chip Select Logic

All the functions of the 6532 are selected by the address lines A0 through A6, the Register Select pin, RS*, and the Chip Select pins CS1 and CS2*. (In addition, direction of data transfer is controlled by the R/W* pin.) The "SELECT FUNCTION" outputs of the block in Figure A5-1 are implicit control signals that go to the Data Direction Registers, the RAM, the Programmable Interval Timer and the Interrupt Register.

Data Direction Register

The Data Direction Register is programmed from the 6532 data bus (R/W* low). The function of the Data Direction Register is to set the direction of the input/output pins. Each input/output pin is programmed as an input or an output. Writing 0 (1) to the Data Direction Register programs the corresponding pin as an input (output).

Buffers

The Buffers in Figure A5-1 are complex I/O logic. A buffered input connected to a TTL-compatible source will be read as high or low appropriately. However, a buffered input is normally pulled high, so an unconnected input will be read as a high.

On output, a buffered output line is latched to the value of the corresponding data bit on the 6532 data bus at the time of addressing the port.

RAM

The 6532 has 128 bytes of RAM.

Programmable Interval Timer

The Programmable Interval Timer is a count-down timer. It can be programmed with an 8-bit count.

The count is decremented at one of four programmable frequencies. When the count reaches zero the timer sets a bit in the Interrupt Register and, if the IRQ* is enabled, also generates an IRQ* signal.

See the fuller description, below.

Interrupt Register

The 2-bit Interrupt Register has two inputs (possible sources of interrupt). Reading the Interrupt Register places its contents in Bits 6 and 7 on the 6532 Data Bus.

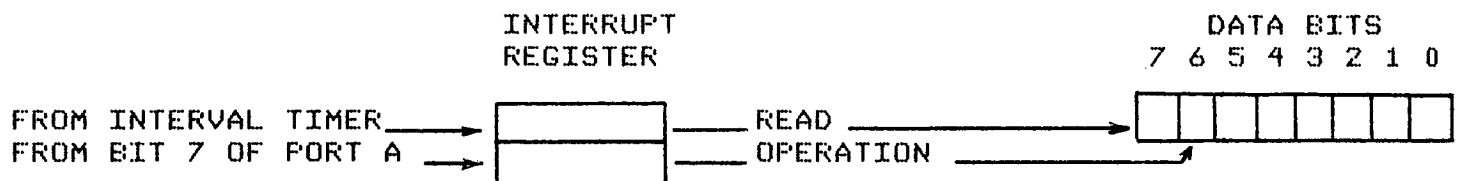

Pin 15 can be programmed as an edge-sensitive input (see Table A5-3). When the outside world connection of pin 15 changes (either 1 to 0 or 0 to 1, according to programming), bit 0 of the Interrupt Register is set and IRQ* will also go low if IRQ* is enabled.

DIFFERENCES BETWEEN PORTS A AND B

There are two 8-bit ports, called Port A and Port B. The ports are almost identical. The differences are listed below.

Only Port A can generate an interrupt

The interrupt from pin 7 of Port A is described above, under Interrupt Register. There is no corresponding function for Port B. The Port A interrupt is not used in the 850.

Port B Buffers can source higher current.

Port B Buffers can source 3 mA at 1.5 Volts. Port A Buffers can source -100 uA at 2.4 Volts.

Read operations differ

When you read Port A, you read the values of the pins (pins 8 through 15). This is the case regardless of whether any pins are programmed as inputs or outputs. When you read Port B, you do not read the pins of bits that are programmed as outputs; instead, these bits always appear to be 1.

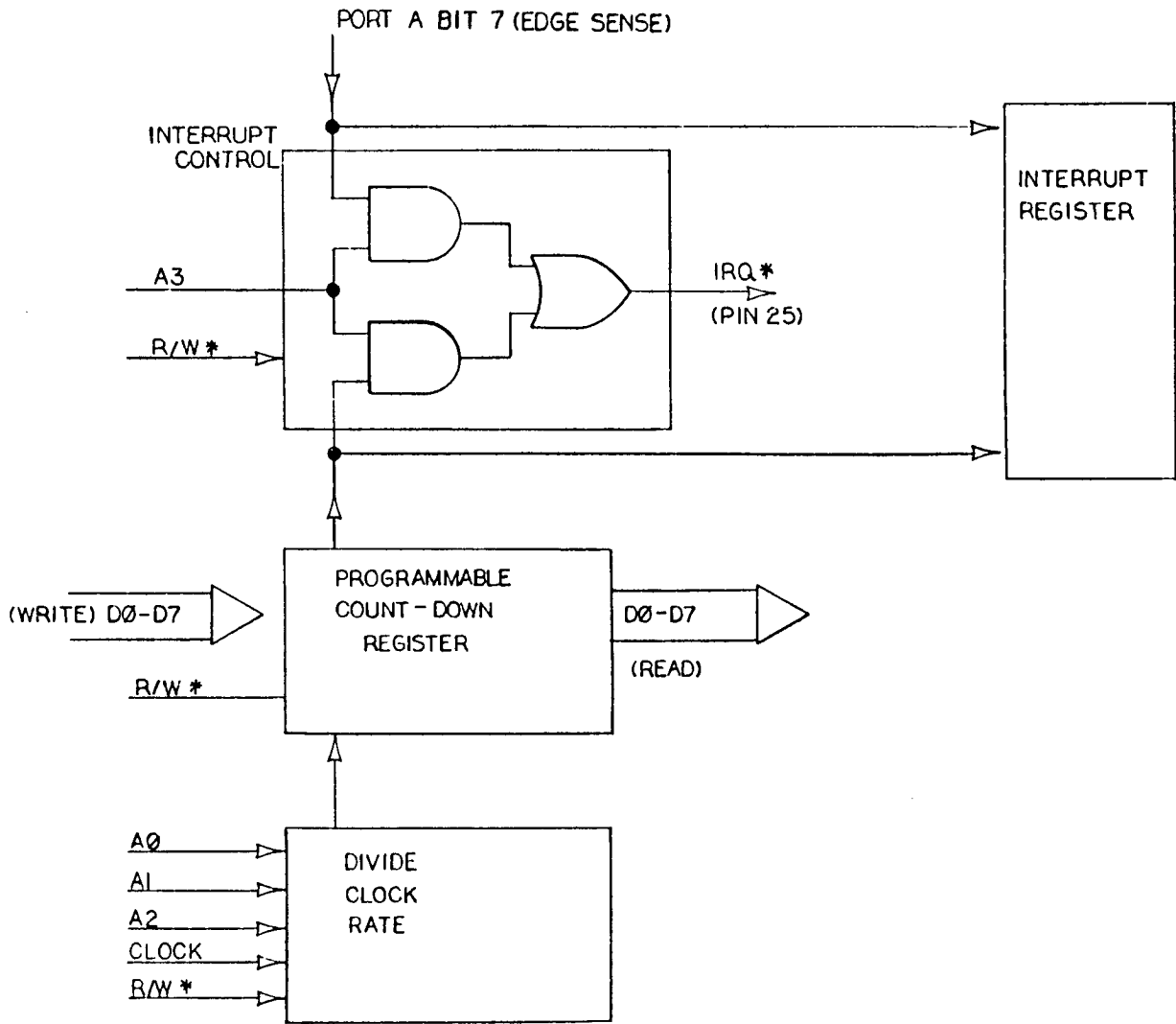

Figure A5-3. Block diagram of the programmable Interval Timer. See text.

PROGRAMMABLE INTERVAL TIMER

The Programmable Interval Timer is described briefly above. A block diagram is given in Figure A5-3.

Three programmable functions are represented in Figure A5-3. These are described below.

1. The 8-bit number to be decremented is written into the Count-Down Register.
2. The ratio of clock pulses to decrement pulses (1, 8, 64 or 1024) is written into the Divide Clock Rate. The ratio is set at the same time as the count-down number described in 1, above.
3. IRQ* is enabled (A3=1) or disabled (A3=0).

Reading the timer gives the number left in the Count-Down Register. After 0, the number wraps around to 11111111 and decrements at the default ratio of 1:1 (clock pulses:decrement pulses).

When the count reaches zero, the Timer Flag of the Interrupt Register is set. In addition, IRQ*, if enabled, is made active (low).

IRQ* is reset by setting or reading the timer.

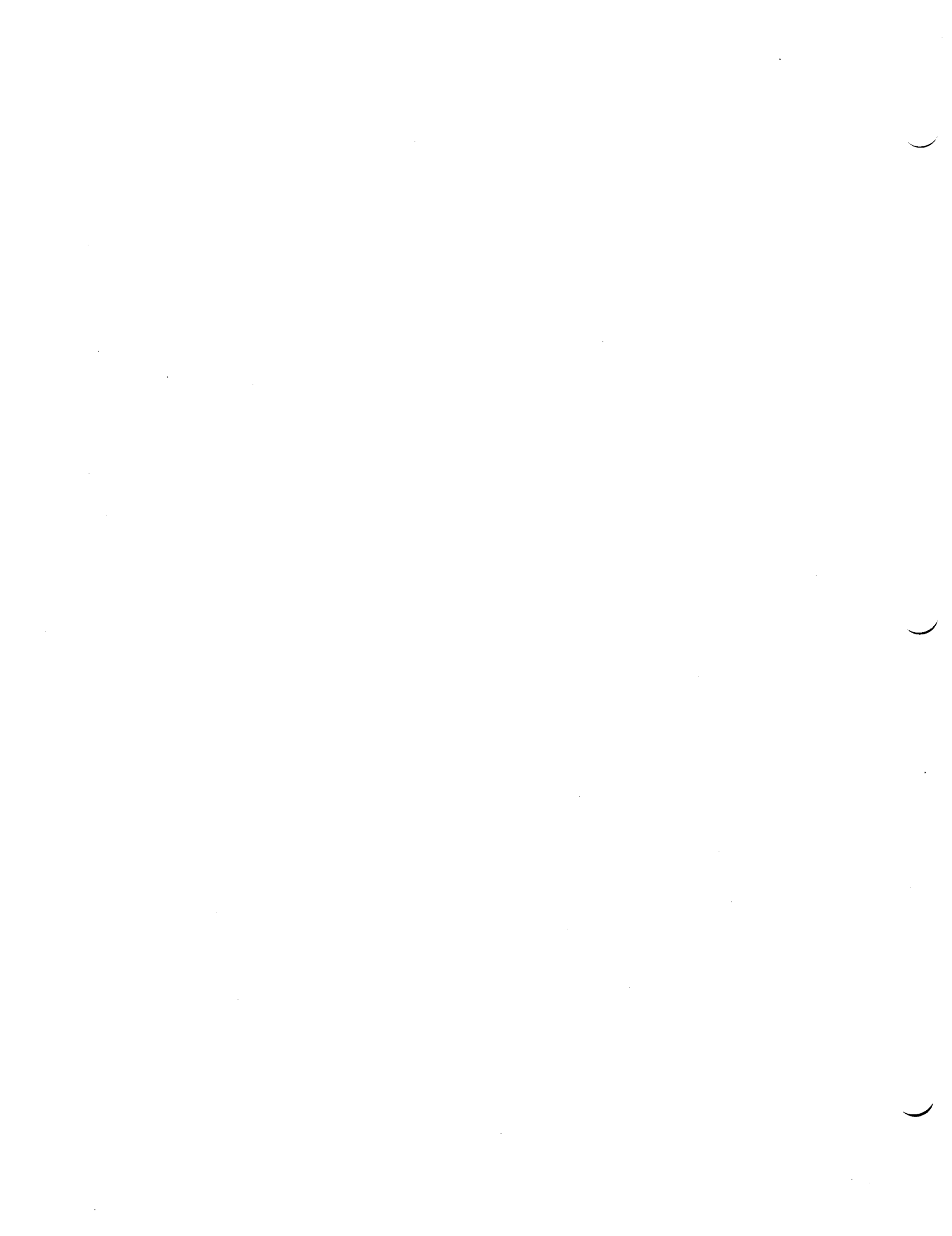

APPENDIX 6

HOW TO DETERMINE REVISION LEVEL

There are two kinds of design revisions--hardware revisions and software revisions.

In general, later revisions are compatible with earlier revisions.

The only hardware revisions of concern to the service technician are those that change the PC Board.

The revision level of the PC Board is printed on the solder side of the PC Board.

The software revision level is printed directly on the ROM itself. The ATARI Part Number terminates with the revision level. For example, a ROM stamped "CO12099-03" contains Revision 3 software.

To find the revision level of the ROM, proceed as follows:

1. Expose the PC Board and remove the top cover of the RF shield.
2. Slide off the metal window in the RF shield and read the Part Number.

To find the revision level of the PC Board, you have to remove the Board from the shell to read the revision level on the solder side.

APPENDIX 7

PORT TEST PROGRAM

PORT TEST PROGRAM

Before using this program, you should make up a DB9 connector with pins 3 and 4 connected. Make this connector from parts S1, S2 and S3 in the spare parts kit (see Appendix 8).

This program tests any serial port. When RUN, the program waits for you to input a line of text (IN\$) after line 60. It then sends IN\$ out of the serial port in use (line 70). The serial port in use is configured (line 30) for concurrent input. The IN\$ sent out of the port can be received by the same port if the output is connected to the input. Do this, before running the program, by connecting pins 3 and 4 of the port. Plug in to the Port being tested (J102, etc.) the special DB9 connector made with the parts supplied in the spare parts kit (see Appendix 8). In an emergency, you may connect pins 3 and 4 of J102, etc. with 18 gauge hook-up wire, or a paper clip, taking care not to damage the jack.

You may also change the BAUD before RUNning the program. Do so by changing the value of BAUD in line 20. The Baud rates corresponding to numbers 0 through 15 are given in Table A7-1. The default BAUD is 300.

Variation of Baud will affect the rate of display up-dating. You can use this to verify that Baud rate is being controlled appropriately.

In varying Baud you may also find that a particular port is functioning perfectly at all but the highest Baud rates. You should in that case replace the appropriate buffer IC.

The IN\$ is received by line 80 and displayed, as OK\$, by line 90. The original IN\$ stays on the screen, so you can compare the two versions for transmission errors.

In using variations of this program, remember that the Interface Module in its default configuration imposes "light" translation. (Refer to the Operator's Manual for a description). Thus, 13 decimal received at a port is translated to 155 decimal internally.

This port test does not test all the functions of a serial port. In particular, it does not test handshaking signals. However, most problems involving these signals are solved by replacement of port buffers or PIAs. If you suspect that a control signal is not being properly transmitted, you can examine that control line with your oscilloscope, while exercising it with a small BASIC program. Also, you can read an outgoing control line by connecting it to an incoming line, again using a small BASIC program to read the incoming line.

```

10 DIM IN$(30),OK$(30)
20 BAUD=1:REM Make BAUD 0, 1, 2, ..., 15. See Table A7-1
30 XIO 36,#2,BAUD,0,"R2:":REM or R1 or R3 or R4
40 OPEN #2,13,0,"R2:"
50 XIO 40,#2,0,0,"R2:" :REM No configuration commands after XIO 40
60 INPUT IN$
70 PRINT #2;IN$: REM Output IN$ though Port 2
80 INPUT #2,OK$: REM Input IN$ through Port 2, and rename it OK$
90 PRINT OK$
95 CLOSE #2
99 END

```

Table A7-1. Baud rates corresponding to values of BAUD in line 30 of the Port Test Program

BAUD	Baud Rate (bits per second)
0	300
1	45.5
2	50
3	56.875
4	75
5	110
6	134.5
7	150
8	300
9	600
10	1200
11	1800
12	2400
13	4800
14	9600
15	9600

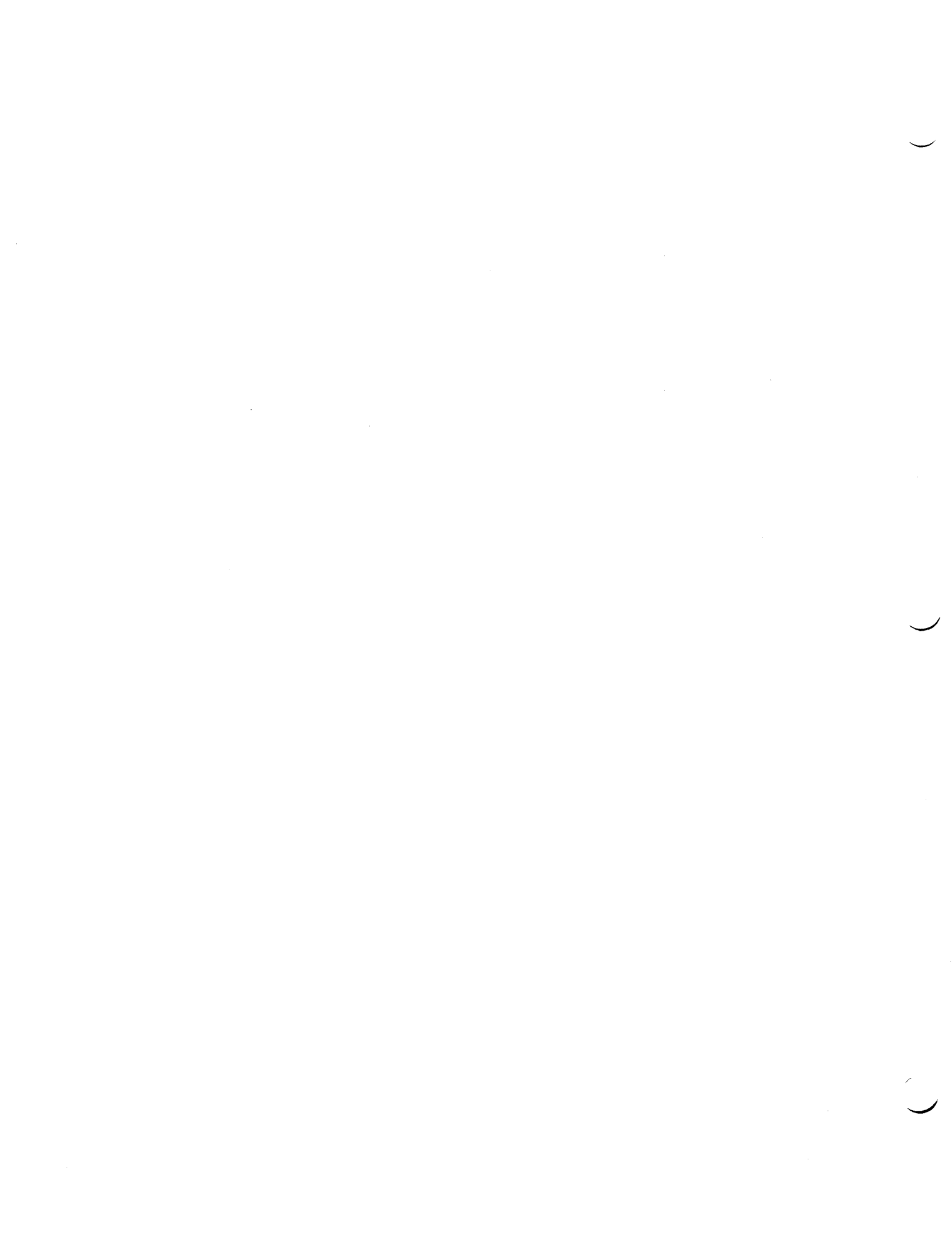

APPENDIX 8

**COMPLETE PARTS LIST AND
PARTS LIST OF SERVICE AND REPAIR KIT**

The complete parts list and Service Kit parts list is given in the next three pages. The short list (18 items) is mainly for the PC Board and its assembled components, mostly ICs. The long list (56 items) is for all the other components on the PC Board. The S list (S1 through S3) are the parts for making the special DB9 connector (see Appendix 7). The complete list of parts is given under the heading "Qty". The parts included in the Repair and Service Kit are given under the heading "Kit".

Table A8-1. Complete Parts List and Kit Parts List (part a).

Item	Part No.	Kit	Qty.	Description
1	CO10174	8	5	CA3086 IC A107-A111
2	CO12099	2	1	4K X 8 Bit Rom A102
3	CO10750	4	2	6532 A103, A104
4	CO10745	4	1	6507 MPU A101
5	CO14334	8	1	4013B Dual D Flip Flop CMOS Z102
6	CO11465-01	8	1	4069 CMOS Hex Inverter Z101 (ALTERNATE LISTED)
7	CO15769	8	2	LM349 Quad OP-AMP A105, A106
8				
9	CO15521	4	1	Top Shield
10	CO15522	4	1	Bottom Shield
11	CO15523	4	1	Rom Access Door
12	CA015546		1	PCB Sub-Assembly
13	CO11465-04		-	ALTERNATE FOR ITEM 6
14	CO15945	8	10	SCREW LOCK STAND-OFF KIT
15	CO14641-12		1	PCB SERIALIZATION LABEL
16	CO15970	4	1	TOP HOUSING
17	CO15971	4	1	BOTTOM HOUSING
18	CO15972	4	1	NAMEPLATE LABEL
S1	CO15578-09	1		DB9 Connector body
S2	CO15579-09	1		DB9 Connector shield clamp
S3	CO15583	2		DB9 Connector pins

Table A8-1. Complete Parts List and Kit Parts List (part b).

Item	Part No.	Kit	Qty.	Description
1	C014179-12	4	2	68pf + 5% CERAMIC AXIAL 50WVDC, C144,146
2	C014179-01	4	1	22pf + 5% CERAMIC AXIAL 50WVDC, C145
3	C014180-03	12	12	100pf + 20% CERAMIC AXIAL 50WVDC, C114,115,120,121, C124,125,127,128,130,132,133,134
4	C014181-01	12	22	.001uf +80%-20% CERAMIC AXIAL 25WVDC, C101-113,116-119 C122,123,126,129,131
5	C014181-03	12	6	.1uf +80%-20% CERAMIC AXIAL 25WVDC, C148-153
6	C010394	4	1	.22uf +20% POLYESTER FILM 100V, C140
7	C014773	4	1	1uf +50%-10% ELECTROLYTIC RADIAL 16V, C135
8	C014392	4	3	10uf +50%-10% " " " C137,143,147
9	C014368	4	2	470uf +50%-10% " " " C141,142
10	C015999	4	1	1000uf +50%-10% " " " C139
11	C014373	4	2	2200uf +50%-10% " AXIAL " C136,138
12				
13	C015386		1	P.C. BOARD
14	C014386-02		9	14 PIN SOCKETS, A105-111,Z101,102
15	C015795-01		1	24 PIN ZERO INSERTION FORCE SOCKET, A102
16	C014386-08		1	28 PIN SOCKET, A101
17	C014386-09		2	40 PIN SOCKET, A103,104
18	C015581-09	4	4	9 PIN CONNECTORS, RIGHT ANGLE, FEMALE, J102-105
19	C012995	4	2	13 PIN I/O CONNECTORS, RIGHT ANGLE, MALE, J106,107
20	C015581-15	2	1	15 PIN CONNECTOR, RIGHT ANGLE, FEMALE, J101
21	CA015325	2	1	LED AND STANDOFF ASSEMBLY, CR122
22	C014397-01	4	1	SWITCH POWER-ON, ROCKER, RIGHT ANGLE, S101, (ALTERNATE LISTED)
23	C014715	2	1	POWER JACK, J108
24	CA016075	4	1	SUB-ASSEMBLY HEATSINK AND REGULATOR, A112
25	C012284	4	1	CRYSTAL 4.433618 MHZ, X101
26				
27	C014348	4	1	7805 5V 3 TERMINAL REGULATOR, A113
28	33-2N3906	8	2	2N3906 TRANSISTOR, Q101,102
29	34-2N3904	4	1	2N3904 " Q103
30	31-1N4001	12	8	1N4001 RECTIFIER DIODE, CR112-119
31	31-1N914	12	12	1N914 LOGIC DIODE, CR101-110,121,123
32	C014808-05	12	1	1N5239B 9.1 ZENER DIODE, CR111
33	C016364	12	1	1N5818 RECTIFIER, (SCHOTTKY) DIODE, CR120
34	14-5101		2	100 ohm, 1/4W, 5%, RESISTOR, R169,170

Item	Part No.	Kit	Qty.	Description
35	14-5151		1	150 ohm, 1/4W, 5%, RESISTOR, R143
36	14-5221		1	220 ohm, 1/4W, 5%, RESISTOR, R160
37	14-5391		1	390 ohm, 1/4W, 5%, RESISTOR, R139
38	14-5561		1	560 ohm, " " " R156
39	14-5102		2	1K ohm, " " " R150,151
40	14-5122		2	1.2K ohm, " " " R161,165
41	14-5182		4	1.8K ohm, " " " R133,138,159,172
42	14-5302		2	3K ohm, " " " R152,153
43	14-5472		12	4.7K ohm, " " " R101,125-128,131,132, R136,137,141,148,166
44	14-5103		23	10K ohm, 1/4W, 5%, RESISTOR, R102-121, 157,164,171
45	14-5473		1	47K ohm " " " R149
46	14-5104		3	100K ohm " " " R146,147,167
47	14-5224		1	220K ohm " " " R158
48	14-5105		1	1M ohm " " " R168
49	C015728		1	75 ohm 2W RESISTOR R155
50	15-5681		1	680 ohm, 1/2W RESISTOR R142
51	C014397 -02		-	ALTERNATE FOR ITEM 22
52	C014796		-	LATCHING FASTENER (ALTERNATE FOR ITEM 53)
53	C015344		14	RIVET,NYLON (SEE ITEM 52 FOR ALTERNATE)
54				
55	14-5100		8	10 ohm, 1/4W,5%, RESISTOR, R122-124,129,130,134,135, 140
56	14-5181		1	180 ohm, 1/4W,5%,RESISTOR, R154

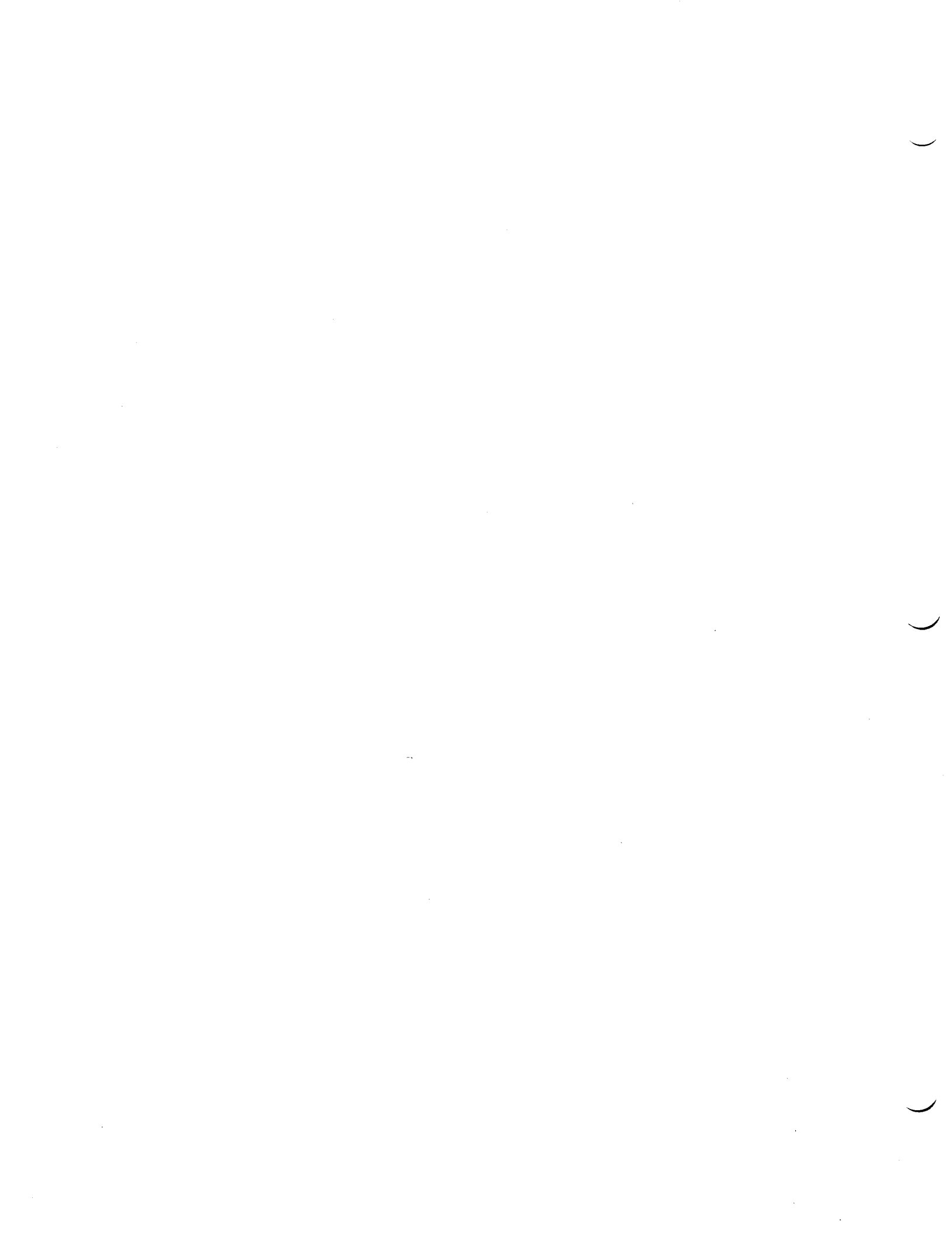

APPENDIX 9

CHECKING ADDRESS LINES

CHECKING ADDRESS LINES

You can check the electrical integrity of the address lines with an oscilloscope while the microprocessor is operating. Proceed as follows:

1. Expose the PC Board and remove the top cover of the RF shield.
2. Connect the 850 to the System I/O Port of your 400/800.
3. Connect a power adapter to the 850.
4. Power on the 850, then the 400/800.
5. Examine the low-order address line (pin 5 of A101). If the microprocessor is operating, whether the 850 booted or not, pin 5 should show 5 volt pulses at approximately 500 kHz. The waveform is not completely regular.
6. Examine the higher-order address lines. When the 850 is properly booted and monitoring the Command line of the System I/O Port, pins 6 through 10 of A101 should all show irregular 5 volt pulses at frequencies of approximately 500 kHz and lower.

The address lines should be at 0 or 5 volts (ignoring the rapid transitions). Faults are revealed by patterns showing intermediate levels. Crossed address lines have values intermediate between 0 and 5 volts when their values should be different (one at 0 and one at 5 volts). These crossed traces, therefore, show three voltage levels rather than two. Unterminated address lines show a constant, indeterminate value between 0 and 5 volts.

APPENDIX 10

ORDERING AND REPORTING INFORMATION

ORDERING AND REPORTING INFORMATION

Parts must be ordered by part numbers. The part numbers of components are given in Appendix 8.

The Spare Parts Kit for the 950 Interface Module is Part Number CS016681

Authorized Dealer/Service Centers should send orders to:

Customer Service
ATARI, Inc.
1346 Bordeaux
Sunnyvale, Ca 94086

The Dealer Service Center is required to report information to ATARI on the incidence of defects.

The procedures to follow are described in the Field Service Administration Manual.

APPENDIX 11

SCHEMATIC, TIMING DIAGRAM, PIN FUNCTIONS AND PLACEMENT OF ICs

FIGURE A11-1. SCHEMATIC

FIGURE A11-2. PRINTER PORT TIMING DIAGRAM

FIGURE A11-3. PIN FUNCTIONS OF THE PRINTER PORT (15-PIN FEMALE CONNECTOR)

FIGURE A11-4. PIN FUNCTIONS OF SERIAL PORT NO. 1 (9-PIN FEMALE CONNECTOR)

FIGURE A11-5. PIN FUNCTIONS OF SERIAL PORTS NOS. 2 AND 3 (9-PIN FEMALE CONNECTORS)

FIGURE A11-6. PIN FUNCTIONS OF SERIAL PORT NO. 4 (9-PIN FEMALE CONNECTOR)

FIGURE A11-7. HOOK-UP OF SERIAL PORT NO. 4 WITH A 20 mA CURRENT LOOP

FIGURE A11-8. PIN FUNCTIONS OF SYSTEM I/O PORT (13-PIN MALE CONNECTOR)

FIGURE A11-9. PLACEMENTS OF ICs ON THE PC BOARD

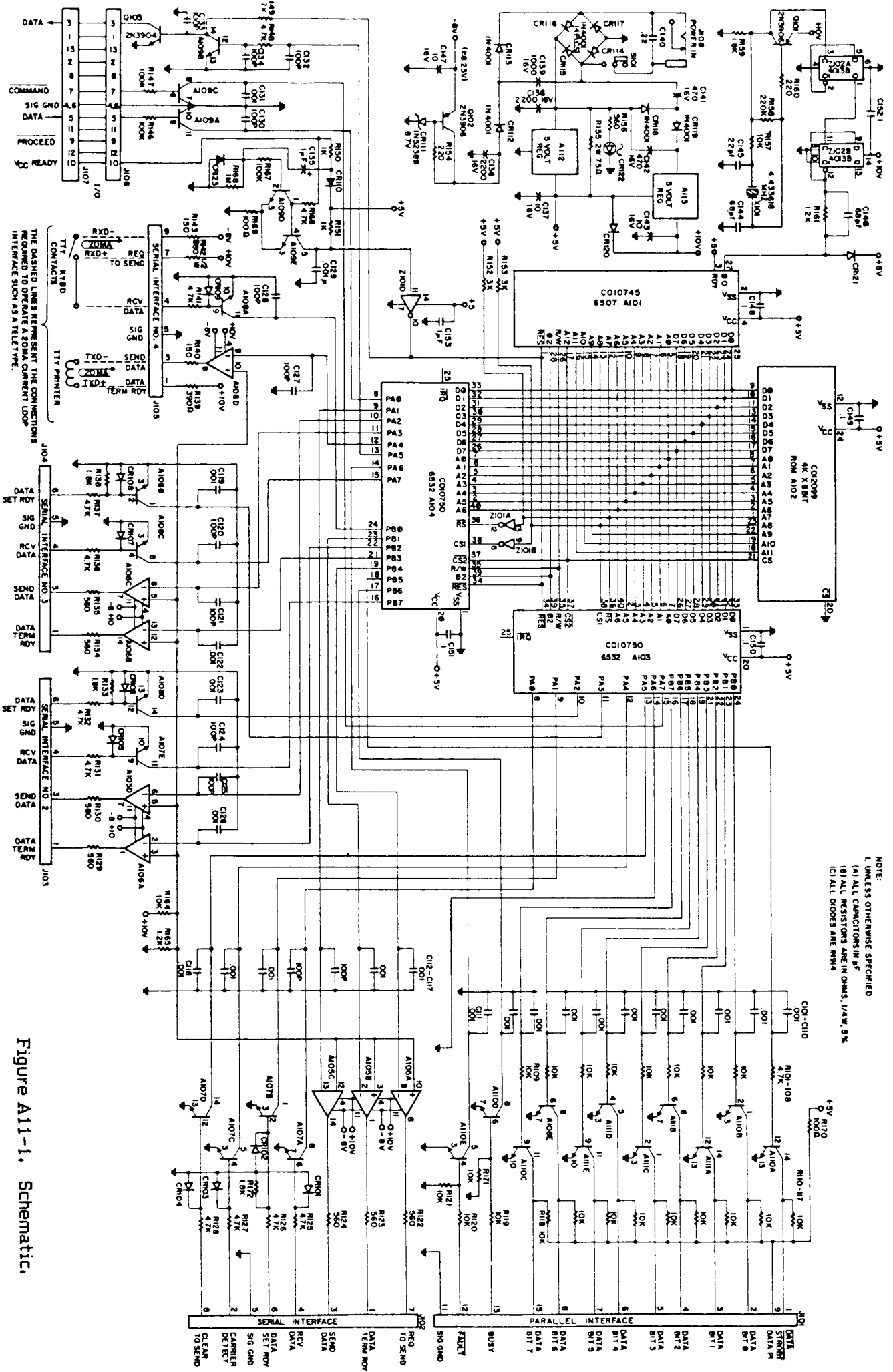
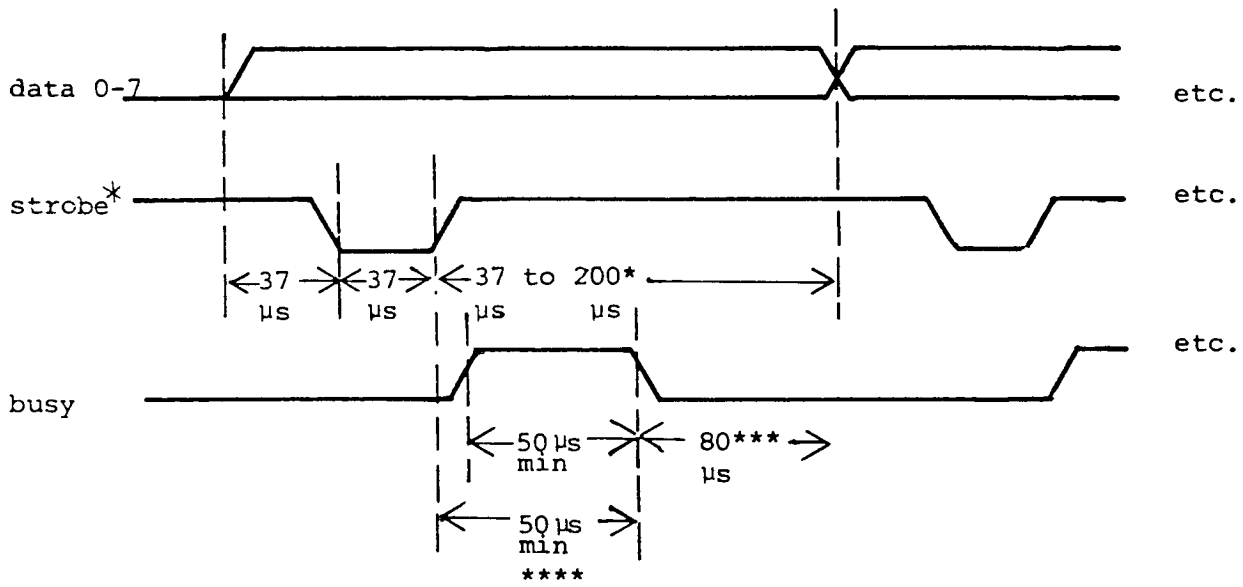

Figure A11-1, Schematic



* one byte sent every 280 μs without Busy

** pulse must be $\geq 50 \mu\text{s}$, no maximum. However, 40 characters must be accepted by printer in 4 sec.

*** approximate

**** Busy may follow either leading or trailing edge of strobe, but it must remain at least 50 μs after trailing edge of strobe.

Figure A11-2. Printer Port timing diagram.

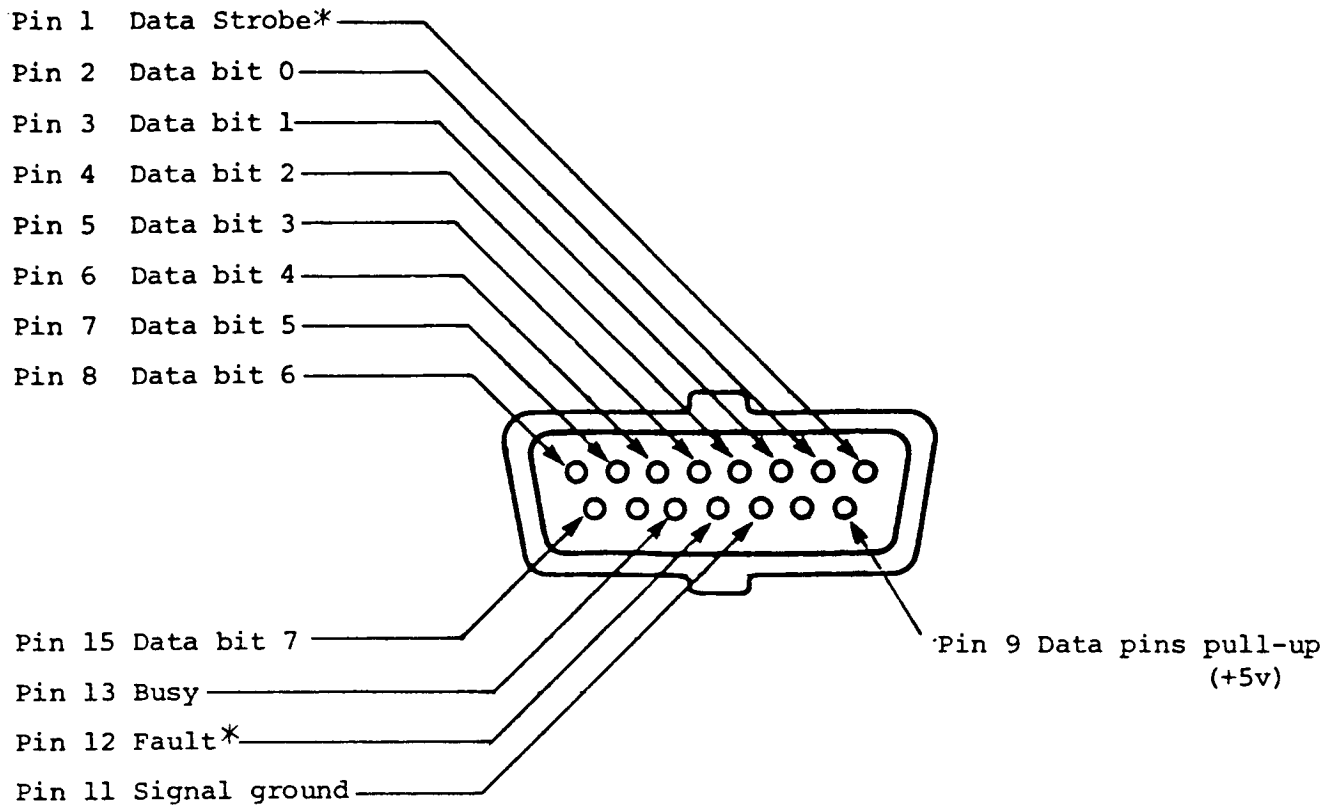

Figure A11-3, Pin functions of the Printer Port (15-pin female connector).

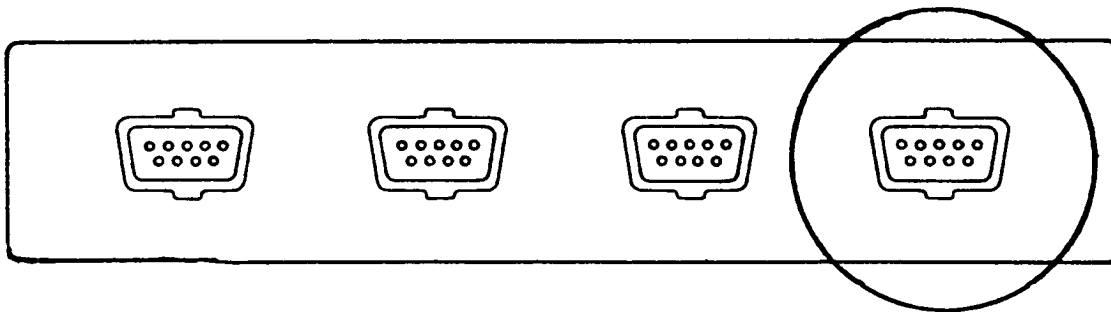
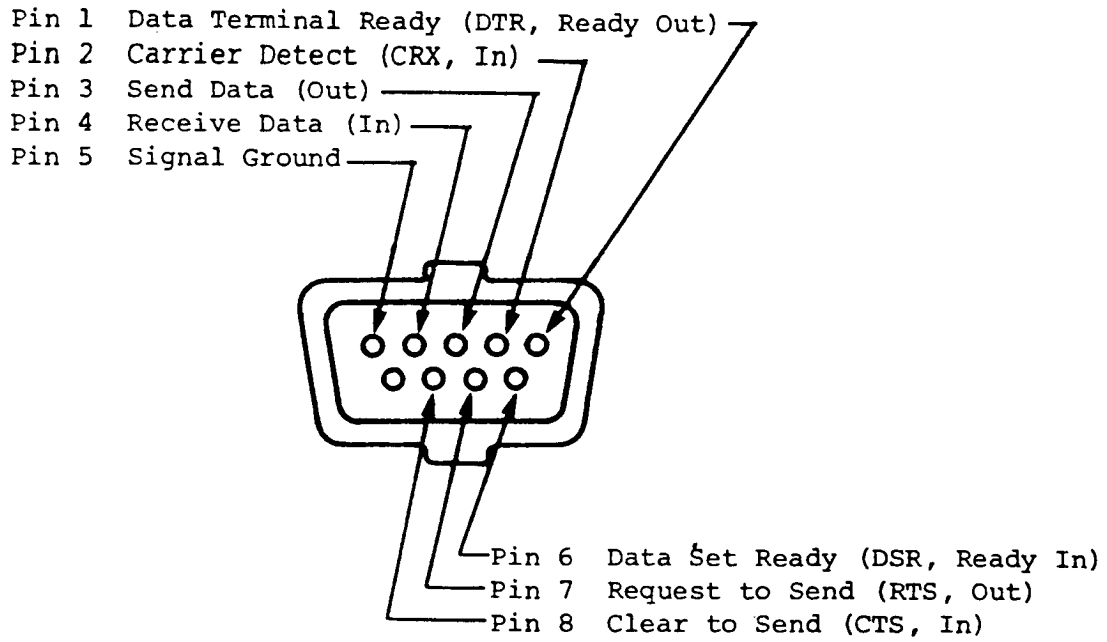

Figure A11-4. Pin functions of Serial Port No. 1 (9-pin female connector).

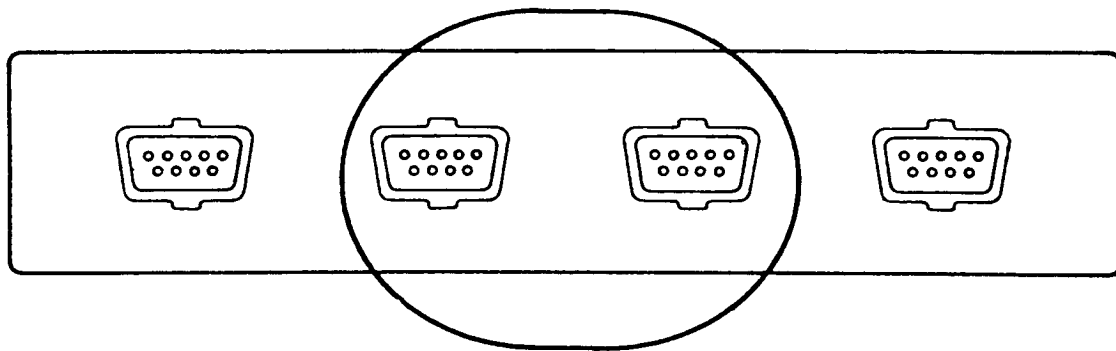
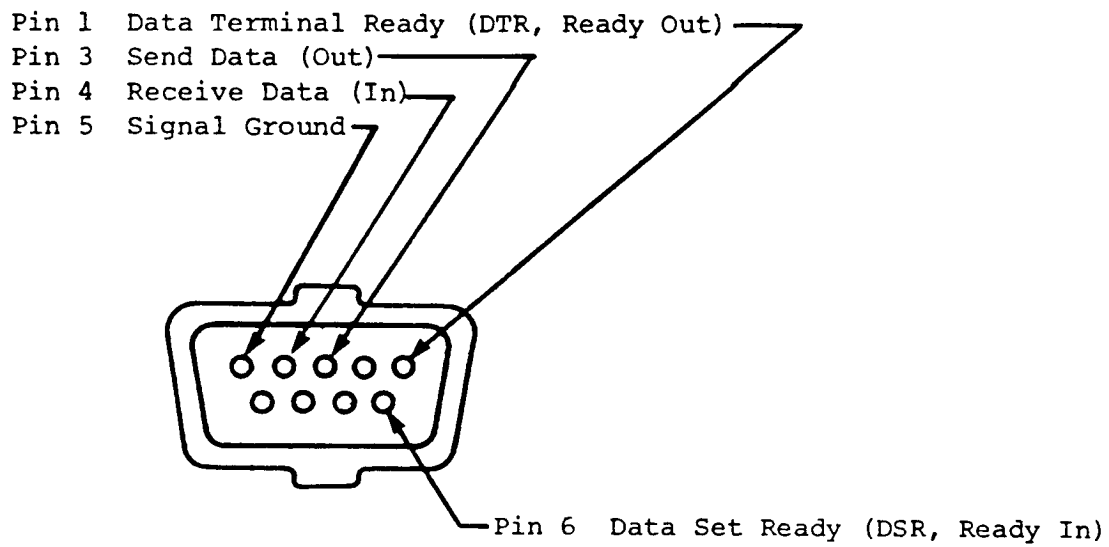

Figure A11-5. Pin functions of Serial Ports Nos. 2 and 3 (9-pin female connectors).

*These pins are not computer-controlled and are always ON (+10v).

- Pin 1 Data Terminal Ready (DTR, Ready Out)*
- Pin 3 Send Data (Out)
- Pin 4 Receive Data (In)
- Pin 5 Signal Ground

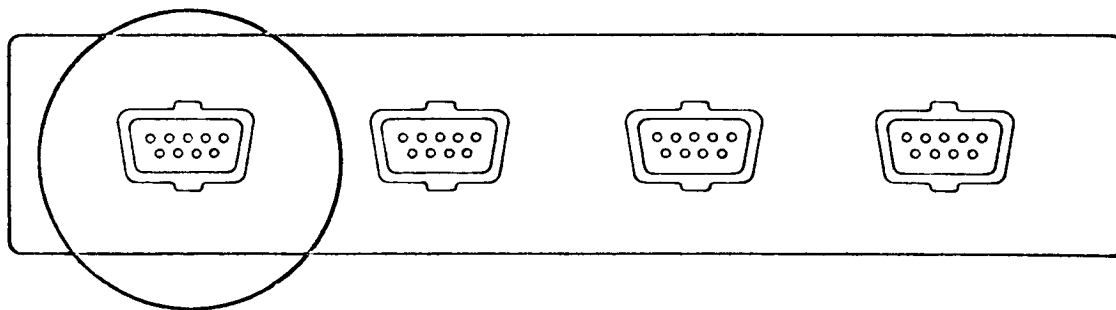
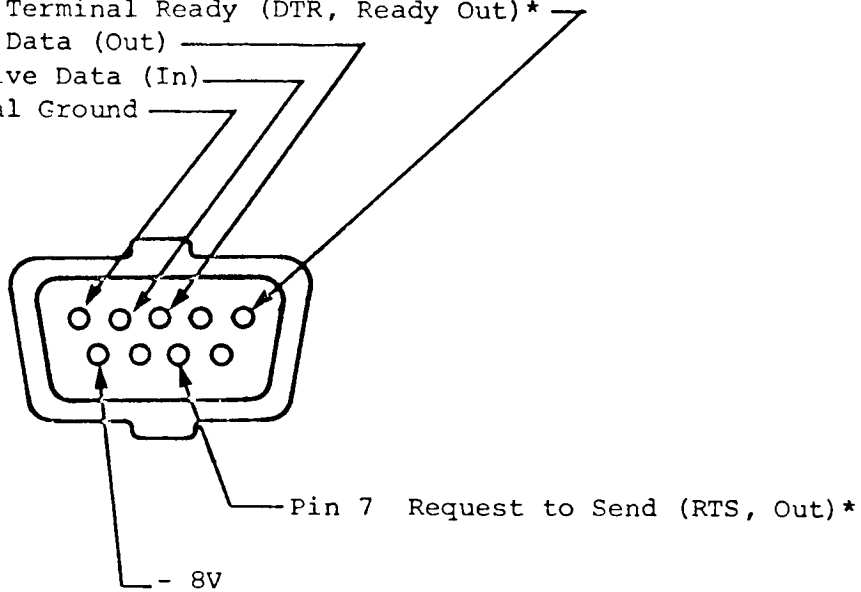

Figure A11-6. Pin functions of Serial Port No. 4 (9-pin female connector).

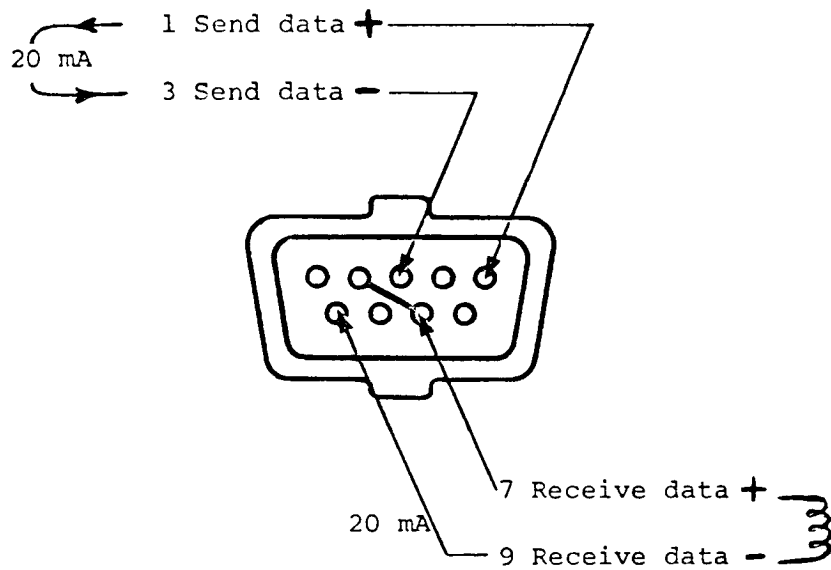

Figure A11-7. Hook-up of Serial Port No. 4 with 20 mA current loop.

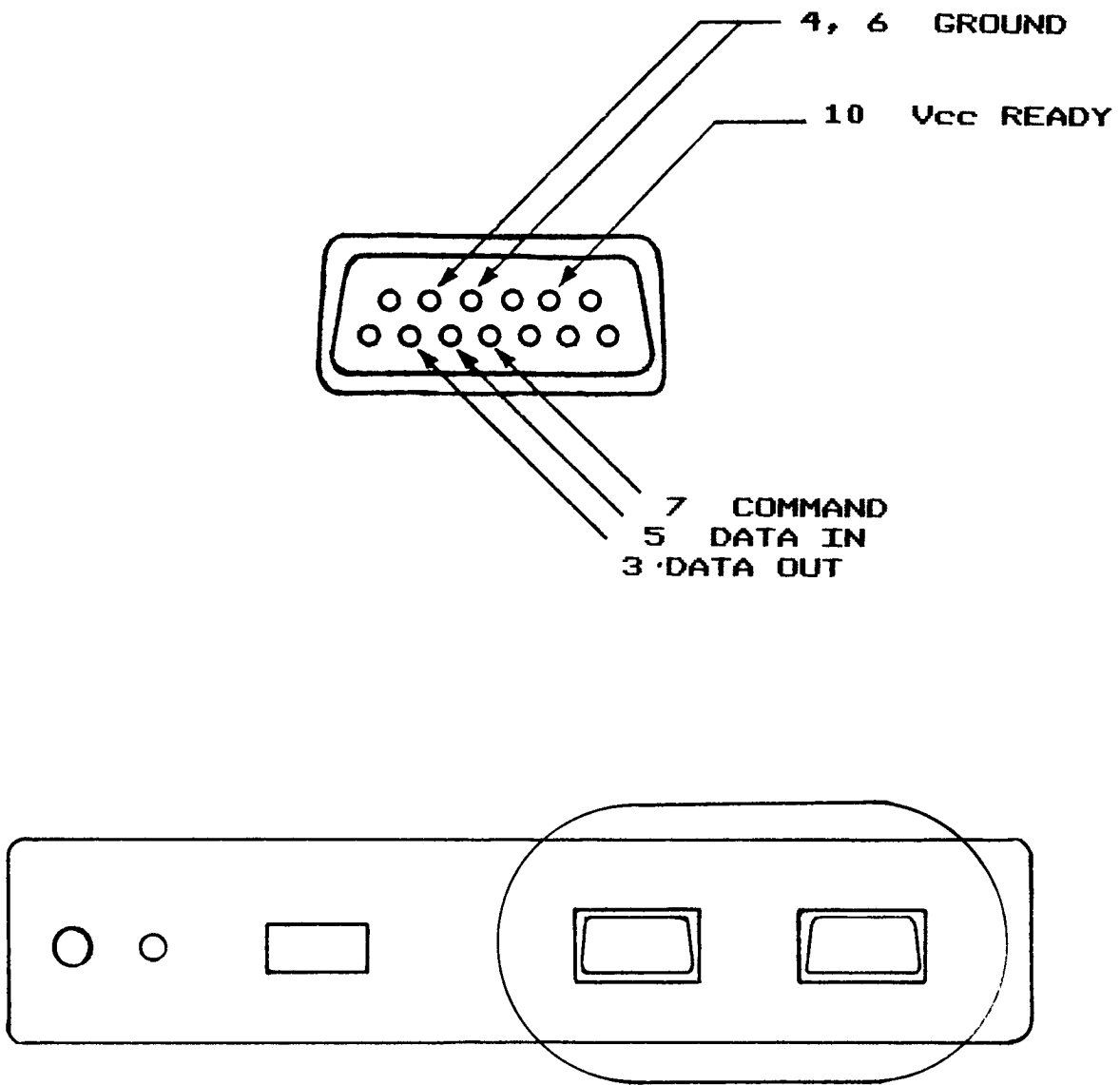

Figure A11-8. Pin functions of the System I/O Port which are used by the Interface Module (13-pin male connector--J106 and J107).

T O P V I E W

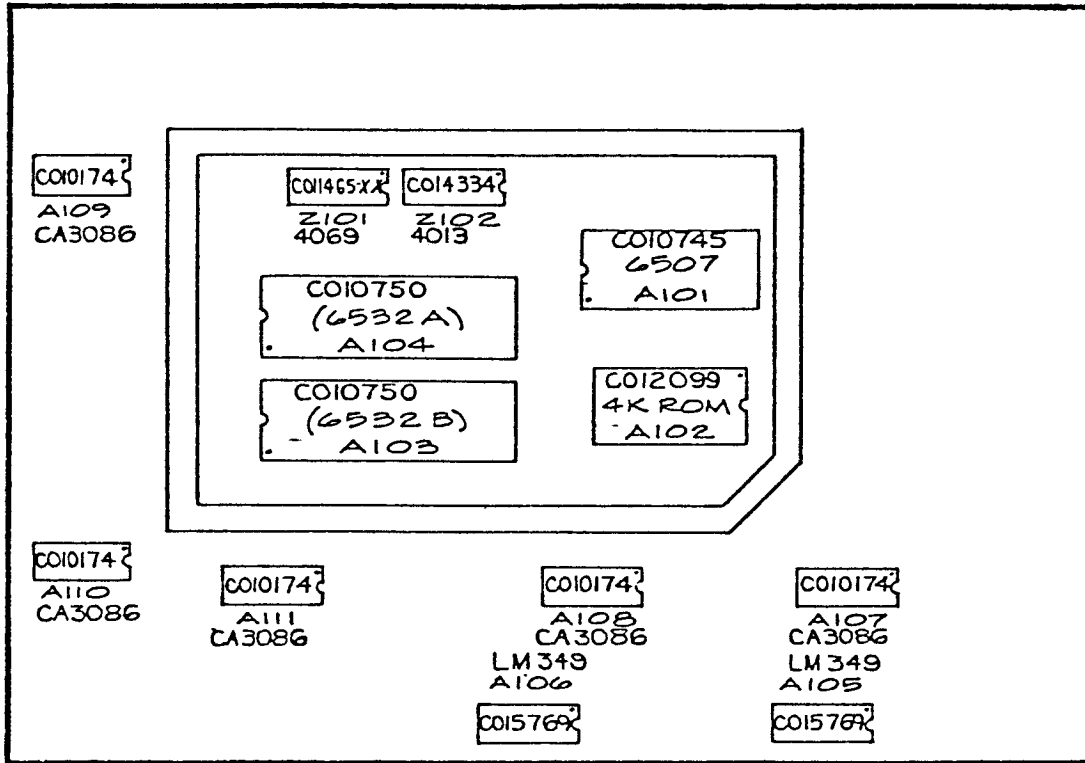

Figure A11-9. Placement of ICs on the PC Board.



A Warner Communications Company 