

6502 GAMES

Learn how to play sophisticated games in the powerful 6502 assembly-level language—and learn the assembly language as well.

6502 Games lets you play the ten games shown below, but it does much more: it teaches assembly language programming in a straightforward and enjoyable manner. You will learn the techniques of algorithm design and data structures so you can program your 6502 not only to play games but also to perform a variety of tasks, from home applications to industrial controls.

With a minimum of external hardware, you will be able to play:

| | | |
|---------------|--------------|-----------|
| Magic Squares | Slot Machine | Music |
| Hexguess | Spinner | Translate |
| Echo | Mindbender | Blackjack |
| Tic-Tac-Toe | | |

THE AUTHOR

Dr. Rodney Zaks has taught courses on programming and microprocessors to several thousand people worldwide. He received his Ph.D. in Computer Science from the University of California, Berkeley, developed a microprogrammed APL implementation, and worked in Silicon Valley, where he pioneered the use of microprocessors in industrial applications. He has authored several best-selling books on microcomputers, now available in ten languages. This book, like the others in the series, is based on his technical and teaching experience.



GHP: 41 TZA1916

RODNEY
ZAKS

P
41

6502 GAMES

TZA
1916

SYBEX

6502 GAMES



rodney zaks

6502
SERIES
VOLUME IV

SYBEX

36
561005

6502 GAMES

RODNAY ZAKS



6502 SERIES — VOLUME 4

ACKNOWLEDGEMENTS

The author would like to acknowledge the contributions of Chris Williams and Eric Novikoff, who thoroughly checked all of the games programs and contributed numerous ideas for improvements.

The author is particularly indebted to Eric Novikoff for his valuable assistance throughout all phases of the manuscript's production, and for his meticulous supervision of the final text.



41
TZA
1816

8115634

Notice

SYM is a trademark of Synertek Systems, Inc.
KIM is a trademark of MOS Technology, Inc.
AIM65 is a trademark of Rockwell International, Inc.
"COMPUTEACHER" and "GAMES BOARD" are trademarks of Sybex, Inc.

Cover Design by Daniel Le Noury

Technical Illustrations by Guy S. Orcutt and J. Trujillo Smith

Every effort has been made to supply complete and accurate information. However, Sybex assumes no responsibility for its use, nor for any infringements of patents or other rights of third parties which would result. No license is granted by the equipment manufacturers under any patent or patent rights. Manufacturers reserve the right to change circuitry at any time without notice.

Copyright © 1980 SYBEX Inc. World rights reserved. No part of this publication may be stored in retrieval system, transmitted, or reproduced in any way, including but not limited to photocopy, photograph, magnetic or other record, without the prior agreement and written permission of the publisher.

Library of Congress Card Number: 80-50896
ISBN 0-89588-022-9
Printed in the United States of America
Printing 10 9 8 7 6 5 4 3 2 1

CONTENTS

PREFACE ix

1. INTRODUCTION 1

The Games Board.

2. MUSIC PLAYER 20

Play a sequence of up to 255 notes (13 different notes) and record it automatically.

3. TRANSLATE 41

The computer displays a binary number. Each player in turn must press the hexadecimal equivalent as quickly as possible. The first to score 10 wins. Designed for two players.

4. HEXGUESS 59

Guess a 2-digit hex number generated by the computer. The computer will tell you how far off your guess is. You are allowed up to 10 guesses.

5. MAGIC SQUARE 73

Light up a perfect square on the board. Each key inverts some LED pattern. Skill and logic are required.

6. SPINNER 87

A light is spinning around a square. You must catch it by hitting the corresponding key. Every time you succeed, it will spin faster. A game of skill.

7. SLOT MACHINE 99

A Las Vegas type slot machine is simulated, with three spinning wheels. Try your luck.

8. ECHO..... 137

Recognize and duplicate a sound/light sequence (also known as SIMON—a manufacturer trademark).

9. MINDBENDER 162

Play against the dealer (the computer) with a deck of 10 cards. You may hit or stay. Don't bust!

10. BLACKJACK 189

Guess a sequence of numbers generated by the computer. It will tell you how many digits are correct and in the right position (also known as MASTER-MIND—a manufacturer trademark).

11. TIC-TAC-TOE 218

Try to achieve three in a row before the computer does in this favorite game of strategy. The computer's ability improves with yours. Can you outsmart it?

APPENDICES 287

- A. 6502 Instructions—Alphabetic
- B. 6502—Instruction Set: Hex and Timing

INDEX 290

ILLUSTRATIONS

| | | |
|--------------|---|----|
| Figure 1.1: | The Games Board | 3 |
| Figure 1.2: | Speaker Has Been Mounted in Enclosure | 3 |
| Figure 1.3: | Two Wires Must Be Connected to the Power Supply | 5 |
| Figure 1.4: | The Games Board is Connected to the SYM with 2 Connectors | 5 |
| Figure 1.5: | Connecting the Cassette Recorder | 6 |
| Figure 1.6: | The System is Ready to be Used | 6 |
| Figure 1.7: | Games Board Elements | 7 |
| Figure 1.8: | The LEDs | 8 |
| Figure 1.9: | Decoder Connection to Keyboard | 9 |
| Figure 1.10: | Detecting a Key Closure | 10 |
| Figure 1.11: | LED Connection | 11 |
| Figure 1.12: | LED Arrangement on the Board | 11 |
| Figure 1.13: | Detail for LED Connection to the Ports | 12 |
| Figure 1.14: | Games Board Detail | 13 |
| Figure 1.15: | VIA Connection to Keyboard Decoder | 14 |
| Figure 1.16: | GETKEY Flowchart | 15 |
| Figure 1.17: | GETKEY Program | 17 |
| Figure 1.18: | “Production” Games Board | 19 |
| Figure 1.19: | Removing the Cover | 19 |
| Figure 2.1: | Playing Music on the Keyboard | 20 |
| Figure 2.2: | Simple Tunes for Computer Music | 21 |
| Figure 2.3: | Generating a Tone | 22 |
| Figure 2.4: | Low Memory: The Tables | 24 |
| Figure 2.5: | Frequency for the Middle C Octave | 25 |
| Figure 2.6: | Note Constants | 27 |
| Figure 2.7: | Music Flowchart | 28 |
| Figure 2.8: | PLAYIT Flowchart | 30 |
| Figure 2.9: | Music Program | 31 |
| Figure 2.10: | Entering a Note in the List | 37 |
| Figure 3.1: | Prompt Signals the Right Player to Play | 42 |
| Figure 3.2: | Bottom Row of LEDs Displays Number to be Guessed | 42 |
| Figure 3.3: | It is Player 2's Turn (Left Player) | 42 |
| Figure 3.4: | Translate Flowchart | 44 |
| Figure 3.5: | LED Connections | 45 |
| Figure 3.6: | Translate Program | 49 |
| Figure 3.7: | Random Number Generation | 58 |
| Figure 4.1: | Hexguess Flowchart | 61 |
| Figure 4.2: | Hexguess Program | 63 |
| Figure 4.3: | 6522 VIA Memory Map | 66 |
| Figure 4.4: | Collecting the Player's Guess | 67 |
| Figure 4.5: | Creating the LED Pattern | 70 |
| Figure 5.1: | Magic Square Flowchart | 79 |
| Figure 5.2: | Complementation Table | 80 |
| Figure 5.3: | Magic Square Program | 81 |

| | | |
|---------------|--|-----|
| Figure 6.1: | Spinner Flowchart | 90 |
| Figure 6.2: | Dual Counter | 92 |
| Figure 6.3: | Spinner Program | 93 |
| Figure 7.1: | The Slot Machine | 100 |
| Figure 7.2: | A Win Situation | 101 |
| Figure 7.3: | Slots Flowchart | 102 |
| Figure 7.4: | DISPLAY Flowchart | 104 |
| Figure 7.5: | EVAL Flowchart | 108 |
| Figure 7.6: | Evaluation Process on the Board | 110 |
| Figure 7.7: | An Evaluation Example | 110 |
| Figure 7.8: | The Score Table | 111 |
| Figure 7.9: | Slot Machine Program | 113 |
| Figure 7.10: | Spinning the Wheels | 121 |
| Figure 7.11: | Evaluating the End of a Spin | 125 |
| Figure 7.12: | Creating the LED Pattern | 134 |
| Figure 8.1: | Specify Length of Sequence to Duplicate | 140 |
| Figure 8.2: | Enter Your Guess | 140 |
| Figure 8.3: | Follow Me | 140 |
| Figure 8.4: | Echo Flowchart | 142 |
| Figure 8.5: | Echo Program | 145 |
| Figure 8.6: | Frequency and Duration Constants | 161 |
| Figure 9.1: | Enter Length of Sequence | 163 |
| Figure 9.2: | Enter Your Guess | 163 |
| Figure 9.3: | Player Enters Wrong Guess | 164 |
| Figure 9.4: | One Correct Digit in the Correct Position | 164 |
| Figure 9.5: | Mindbender Flowchart | 166 |
| Figure 9.6: | Low Memory Map | 168 |
| Figure 9.7: | High Memory Map | 169 |
| Figure 9.8: | 6522 VIA Memory Map | 170 |
| Figure 9.9: | Detailed Mindbender Flowchart | 172 |
| Figure 9.10: | Interrupt Registers | 174 |
| Figure 9.11: | 6522 Auxiliary Control Register Selects Timer 1 Operating Modes | 174 |
| Figure 9.12: | Timer 1 in Free Running Mode | 175 |
| Figure 9.13: | Mindbender Program | 184 |
| Figure 10.1: | Indicating the Winner | 190 |
| Figure 10.2: | First Hand | 191 |
| Figure 10.3: | Player Receives A Second Card: Blackjack | 191 |
| Figure 10.4: | End of Turn: Dealer Loses | 192 |
| Figure 10.5: | Second Hand | 193 |
| Figure 10.6: | Blackjack Again | 193 |
| Figure 10.7: | Dealer Busts | 193 |
| Figure 10.8: | Final Score Is 7 | 194 |
| Figure 10.9: | Blackjack Flowchart | 195 |
| Figure 10.10: | Low Memory Map | 196 |
| Figure 10.11: | High Memory Map | 197 |
| Figure 10.12: | Blackjack Program | 212 |
| Figure 11.1: | Tic-Tac-Toe Winning Combinations For a Player | 219 |
| Figure 11.2: | First Computer Move | 219 |

| | | |
|---------------|-------------------------------------|-----|
| Figure 11.3: | Our First Move | 220 |
| Figure 11.4: | Second Computer Move | 220 |
| Figure 11.5: | After the Computer's Third Move | 220 |
| Figure 11.6: | After the Computer's Fourth Move | 221 |
| Figure 11.7: | After the Computer's Fifth Move | 221 |
| Figure 11.8: | Move 1 | 222 |
| Figure 11.9: | Move 2 | 222 |
| Figure 11.10: | Move 3 | 222 |
| Figure 11.11: | Move 4 | 223 |
| Figure 11.12: | Move 1 | 223 |
| Figure 11.13: | Move 2 | 223 |
| Figure 11.14: | Move 3 | 224 |
| Figure 11.15: | "We Win!" | 224 |
| Figure 11.16: | The Six Combinations | 227 |
| Figure 11.17: | Evaluation Grid | 227 |
| Figure 11.18: | Test Case 1 | 228 |
| Figure 11.19: | Evaluation Grid: Row 1 Potential | 229 |
| Figure 11.20: | Evaluating the Horizontal Potential | 229 |
| Figure 11.21: | Evaluating the Vertical Potential | 230 |
| Figure 11.22: | Evaluating the Diagonal Potential | 230 |
| Figure 11.23: | The Final Potential | 230 |
| Figure 11.24: | Evaluation for "O" | 231 |
| Figure 11.25: | Potential Evaluation | 232 |
| Figure 11.26: | Move for Highest Score | 232 |
| Figure 11.27: | Finishing the Game | 232 |
| Figure 11.28: | An Alternative Ending for the Game | 233 |
| Figure 11.29: | Test #1 Evaluation for "X" | 234 |
| Figure 11.30: | Test #1 Evaluation for "O" | 234 |
| Figure 11.31: | Test #2 | 234 |
| Figure 11.32: | Moving to the Center | 235 |
| Figure 11.33: | A Simple Situation | 236 |
| Figure 11.34: | A Reverse Situation | 236 |
| Figure 11.35: | Trap 3 | 237 |
| Figure 11.36: | End of Game | 237 |
| Figure 11.37: | A Correct Move | 238 |
| Figure 11.38: | Row-sums | 240 |
| Figure 11.39: | A Trap Pattern | 241 |
| Figure 11.40: | Board Analysis Flowchart | 242 |
| Figure 11.41: | The Diagonal Trap | 244 |
| Figure 11.42: | Falling Into the Diagonal Trap | 244 |
| Figure 11.43: | Playing to the Side | 245 |
| Figure 11.44: | Actual Game Sequences | 246 |
| Figure 11.45: | Tic-Tac-Toe Flowchart | 248 |
| Figure 11.46: | Tic-Tac-Toe Row Sequences in Memory | 251 |
| Figure 11.47: | Tic-Tac-Toe: Low Memory | 253 |
| Figure 11.48: | Tic-Tac-Toe: High Memory | 254 |
| Figure 11.49: | FINDMV Flowchart | 270 |
| Figure 11.50: | Tic-Tac-Toe Program | 280 |

THE 6502 SERIES

BOOKS

- Vol. 1—Programming the 6502 (Ref. C202)*
- Vol. 2—Programming Exercises for the 6502 (Ref. C203)*
- Vol. 3—6502 Applications Book (Ref. D302)*
- Vol. 4—6502 Games Book*

SOFTWARE

- 6502 Assembler in BASIC*
- Games Cassette for SYM*
- Application Programs*
- 8080 Simulator for 6502 (KIM and APPLE versions)*

EDUCATIONAL SYSTEM

- Computeacher™*
- Games Board™*

PREFACE

“Complex algorithms can be fun!”

Programming is often treated by programmers as a game, although they may not readily admit it. In fact, using and programming a computer may well be one of the ultimate intellectual games devised to date.

A program is a projection of one's intelligence and skills. Writing games programs adds an essential ingredient to it: fun. However, most interesting games are fairly complex to program, and demand specific programming skills.

This book will teach you how to program a complete array of games ranging from passive ones (Music) to strategic ones (Tic-Tac-Toe). In the process of learning how to program these games, you will sharpen your skills at using input/output techniques, such as timers and interrupts. You will also use various data structures, and improve or develop your assembly-level programming skills.

This book has been designed as an *educational text*. After reading it you should be able to create programs for additional games and to use your programming skills for other applications.

If you have access to a microcomputer board, you can also enjoy the results of your work in a very short time. The programs presented in this book are listed for the SYM board (from Synertek Systems), but can be adapted to other 6502-based microcomputers. Playing the games will require building a simple, low-cost “Games Board,” which is described in Chapter 1. To facilitate game playing, a “Games Cassette” is also available in SYM format.

The many games studied in this book include: musical games (MUSIC), educational games (TRANSLATE and HEXGUESS will teach you hexadecimal), games involving the use of logic (MAGIC SQUARES), games involving coordination (SPINNER), memory games (ECHO), games of chance (SLOT MACHINES), games involving strategy (TIC-TAC-TOE), and games involving various combinations of skills (BLACKJACK).

A basic format has been followed in presenting each game program. It includes:

1. The rules of the game
2. Instructions for playing a typical game

3. The algorithm(s) (theory of operation)
4. The program: data structures, programming techniques, subroutines.

Variations and exercises are also suggested throughout the book.

Thus, you will first learn how to play the game, and then how to devise a possible solution (the algorithm). Finally, you will actually implement a complete, programmed version of the algorithm in 6502 assembly-level language, paying specific attention to the required data structures and techniques used for efficient programming.

Learning to program in assembly-level language has traditionally been unappealing or difficult. It need not be. It can be fun. If you are familiar with elementary programming techniques on the level of reference text C202—*Programming the 6502*, this book will teach you practical programming techniques in a game context. It will both integrate theoretical concepts into complex programs and present a simple step-by-step analysis of program development. These same concepts and techniques can be applied to any programming problem, from industrial control to business applications.

It is hoped that you will have as much fun learning how to program as you will have playing the games. If you have invented, developed, or know of other games that you would like to see included in a games book, please write to me.

RODNAY ZAKS

1

INTRODUCTION

PURPOSE

This book has been designed for the programmer who wants to learn advanced programming techniques by using the 6502. It can, of course, also be used by those who simply wish to play games with their 6502-based board. When using this book for educational purposes, the reader should be familiar with the 6502 instruction-set as well as basic programming techniques on the level of the reference text C202 — *Programming the 6502*. A basic knowledge of input/output techniques is also recommended. (See reference D302 — *6502 Applications Book*.)

The games presented in this book range from simple programs to highly complex ones. In order to implement game programs, algorithms will be proposed, and data structures will be designed. This is the process any disciplined computer programmer must go through when designing a programmed solution for a given problem. Game programs usually do not present any serious input/output problems, as some industrial control programs might; however, they often represent a serious intellectual challenge in terms of devising an efficient solution strategy. In addition, all the algorithms and programs presented in this book have been designed to be terse so that they can reside within less than 1K of available memory.

All of the programs presented in this book have been tested on actual hardware by several users and have been found to be error-free in the conditions under which they were tested. As in any large program, however, inadequacies or improvements may be found. The author will be grateful for any comments or suggestions from interested readers.

The programs in this book can be used to play real games. They require using a 6502-based board such as the SYM board (manufactured and trademarked by Synertek Systems) and they require building a simple "Games Board." A complete description of the Games Board will be provided in this chapter. The Games Board is shown in Figure 1.1.

The programs in this book will all run as they are presented on a SYM board, but they can easily be adapted to any other 6502-based computer. The input/output lines available, however, are usually specific to the microcomputer used. The input/output segments of the various programs must then be modified accordingly. Naturally, the algorithms themselves as well as the programming techniques used to implement them normally remain unchanged.

After reading this book, especially if you should try to run the programs on the Games Board, you will probably agree that:

"Complex algorithms can be fun!"

HARDWARE REQUIRED

In order to run the programs presented in this book on an actual microcomputer, a SYM or other 6502-based board should be used. Additionally, a Games Board will be required to play the games. A photograph of the Games Board is shown in Figure 1.1. The Games Board is the input/output board on which the games will be played. The keyboard on the right is used to provide an input to the microcomputer board, while the LEDs on the left are used to display the information sent by the program. The use of the keys and the LEDs will be explained for each game in this book. A speaker is also attached for sound effects. It has been mounted in an enclosure (box), for improved sound quality. (See Figure 1.2.)

The Games Board may easily be built at home from a small number of low-cost components, or may be obtained from Sybex. Since its assembly is quite simple, the reader interested in obtaining a better understanding of the hardware is strongly encouraged to purchase the parts and build the board. On the other hand, building the Games Board is not a required action in order to use this text. It simply offers additional depth of understanding.

CONNECTING THE SYSTEM

It is assumed here that you own a 6502-based microcomputer board, such as a SYM board, and that you have built or obtained a

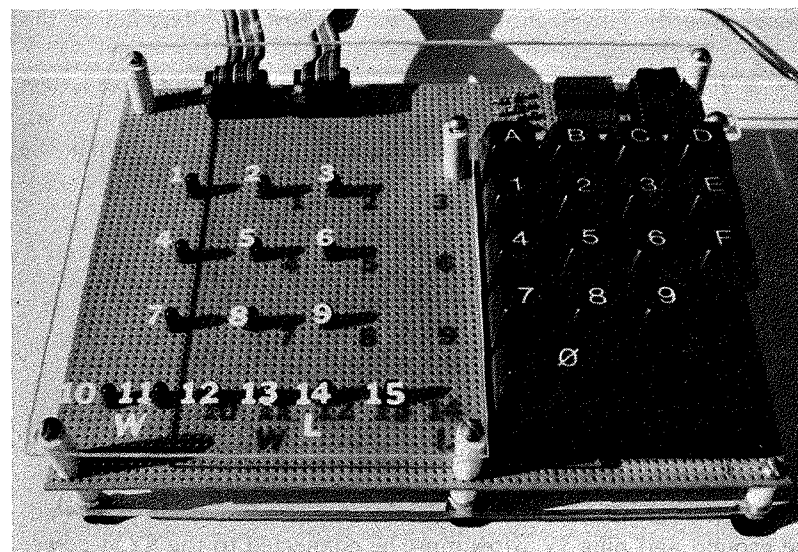

Fig. 1.1: The Games Board



Fig. 1.2: Enclosure May Be Used for Improved Sound

Games Board. This section will describe how to interconnect the elements of the system so that you can actually play the games which will be described in the following chapters. If you do not have access to this hardware, it is not essential that you read through this section. However, you may wish to refer to it later, in order to implement the games described in this book, or to understand the interfacing and input/output techniques.

Four essential components are required:

- 1 - the power supply
- 2 - the SYM board
- 3 - the Games Board
- 4 - (preferably) a cassette recorder

The first requirement is to connect the wires to the power supply. If it is not already so equipped, two sets of wires must be connected to it. (See Figure 1.3.) First, it must be connected to a power cord. Second, the ground and plus 5V wires must be connected to the SYM power connector, as per the manufacturer's specifications.

Next, the Games Board should be physically connected to the SYM. Two edge connectors are required for the SYM: both the A connector and the AA connector are used. (See Figure 1.4.) There is also a power source connector.

Always be careful to insert the connectors with the proper side up (usually the printed side). An error in inserting the power connector, in particular, will have highly unpleasant results. Errors in inserting the I/O connectors are usually less damaging.

Finally, if a cassette recorder is to be used (highly recommended), the SYM board must be connected to a tape recorder. At the minimum, the "monitor" or "earphone" wires should be connected, and preferably the "remote" wire as well. If new programs are going to be stored on tape, the "record" or "microphone" wire should also be connected. (See Figure 1.5.) Details for these connections are given in the SYM manual.

At this point the system is ready to be used. (See Figure 1.6.) If you have one of the games cassettes (available separately from Sybex), simply load the cassette into the tape recorder. Press the RST key after powering up your SYM, and load the appropriate game into your SYM. You are ready to play.

Otherwise, you should enter the hexadecimal object code of the game on the SYM keyboard. All games are started by jumping to location 200 ("GO 200").

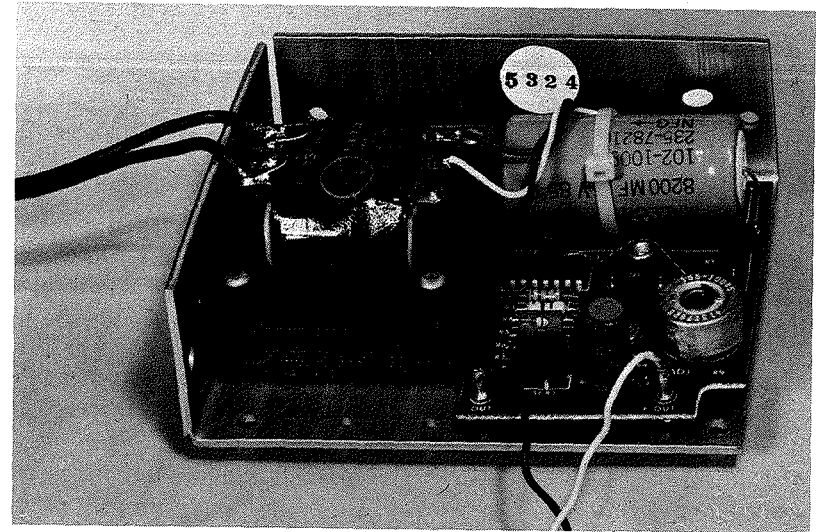

Fig. 1.3: Two Wires Must Be Connected to the Power Supply

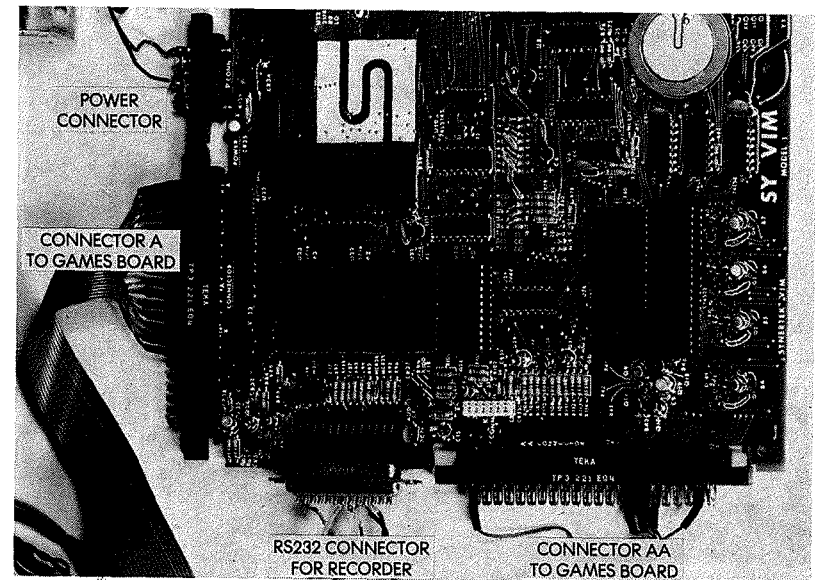

Fig. 1.4: The Games Board is Connected to the SYM with 2 Connectors (Note also Power and Cassette Connectors)

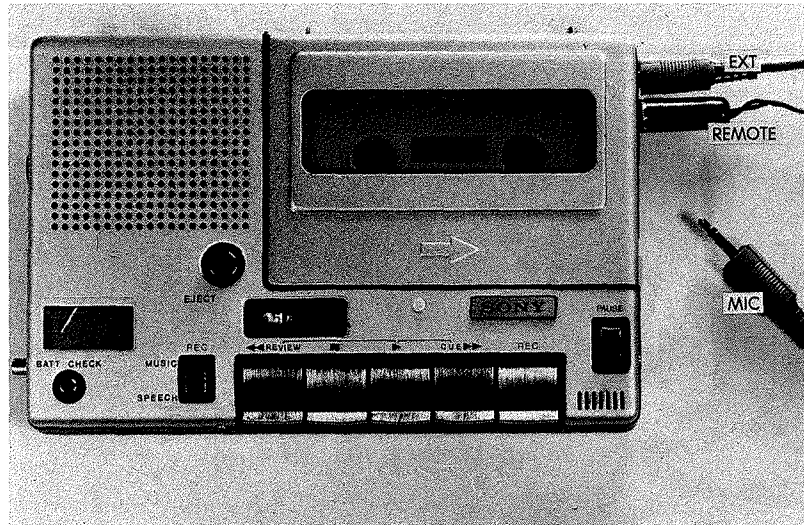

Fig. 1.5: Connecting the Cassette Recorder

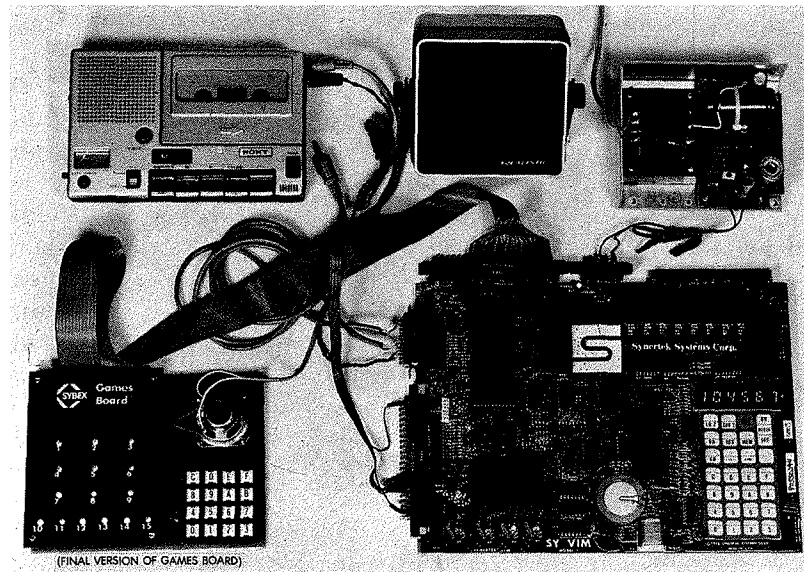

Fig. 1.6: The System is Ready to be Used

GAMES BOARD INTERCONNECT

The Keyboard

The board's components are shown in Figure 1.7. The LED arrangement used for the games is shown in Figure 1.8. The keyboard used here is of the "line per key" type, and does not use a matrix arrangement. Sixteen keys are required for the games, even though more keys are often provided on a number of "standard keyboards," such as the one used in the prototype of Figure 1.7. On this prototype, the three keys at the bottom right-hand corner are not used (keys H, L, and "shift").

Figure 1.9 shows how a 1-to-16 decoder (the 74154) is used to identify the key which has been pressed, while tying up only four output lines (PB0 to PB3) — four lines allow 16 codes. The keyboard scanning program will send the numbers 0-15 in succession out on lines PB0-PB3. In response, the 74154 decoder will decode its input (4 bits) into each one of the 16 outputs in sequence. For example, when the number "0000" (binary) is output on lines PB0 to PB3, the 74154 decoder grounds line 1 corresponding to key "0". This is illustrated in Figure 1.9. After outputting each four-bit combination, the scanning program reads the value of PA7. If the key currently grounded was not pressed, PA7 will be high. If the corresponding key was pressed, PA7 will be grounded and a logical "0" will be read. For example, in

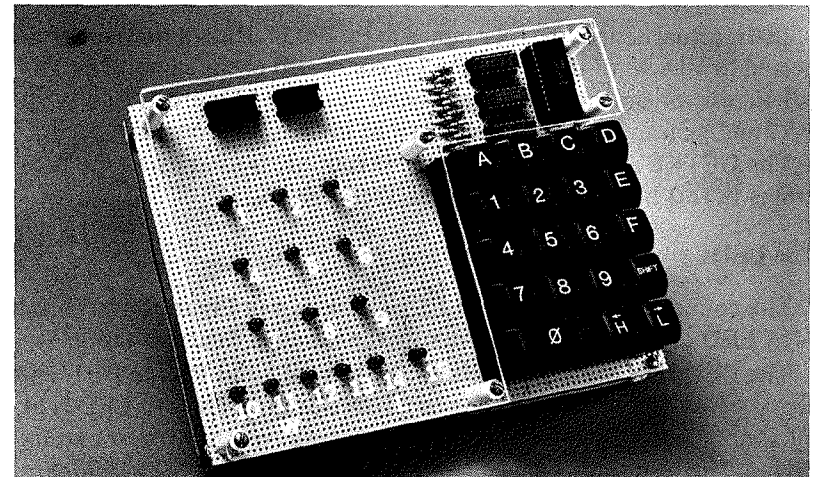

Fig. 1.7: Games Board Elements (Prototype)

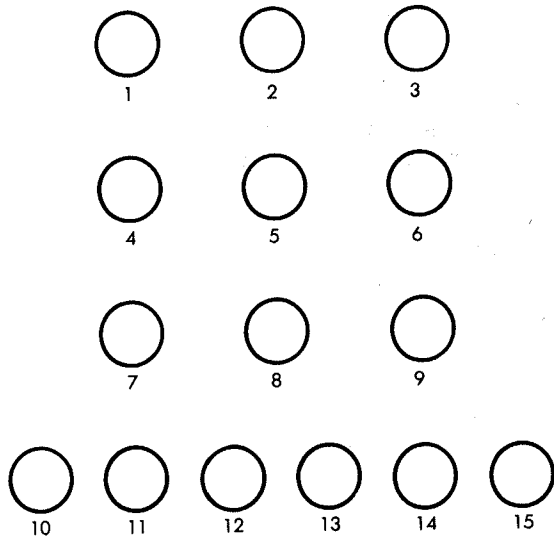

Fig. 1.8: The LEDs

Figure 1.10, a key closure for key 1 has been detected. As in any scanning algorithm, a good program will debounce the key closures by implementing a delay. For more details on specific keyboard interfacing techniques, the reader is referred to reference C207 — *Microprocessor Interfacing Techniques*.

In the actual design, the four inputs to the 74154 (PB0 to PB3) are connected to VIA #3 of the SYM. PA7 is connected to the same VIA. The 3.3 K resistor on the upper right-hand corner of Figure 1.9 pulls up PA7 and guarantees a logic level "1" as long as no grounding occurs.

The GETKEY program, or a similar routine, is used by all the programs in this book and will be described below.

The LEDs

The connection of the fifteen LEDs is shown in Figure 1.11. Three 7416 LED drivers are used to supply the necessary current (16 mA).

The LEDs are connected to lines PA0 to PA7 and PB0 to PB7, excepting PB6. These ports belong to VIA #1 of the SYM. An LED is lit by simply selecting the appropriate input pin of the corresponding driver. The resulting arrangement is shown in Figure 1.12 and Figure 1.13.

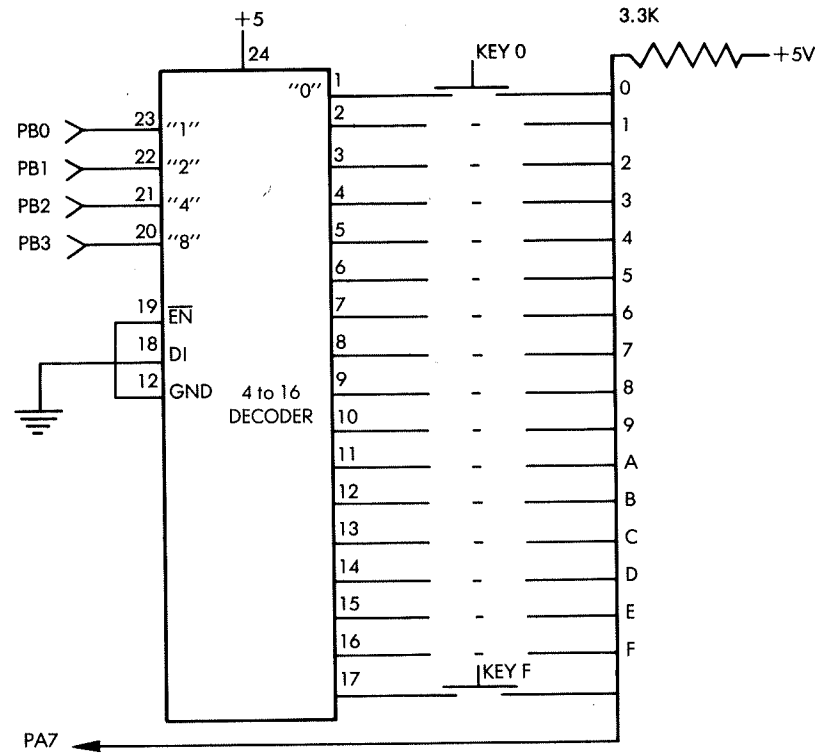

Fig. 1.9: Decoder Connection to Keyboard

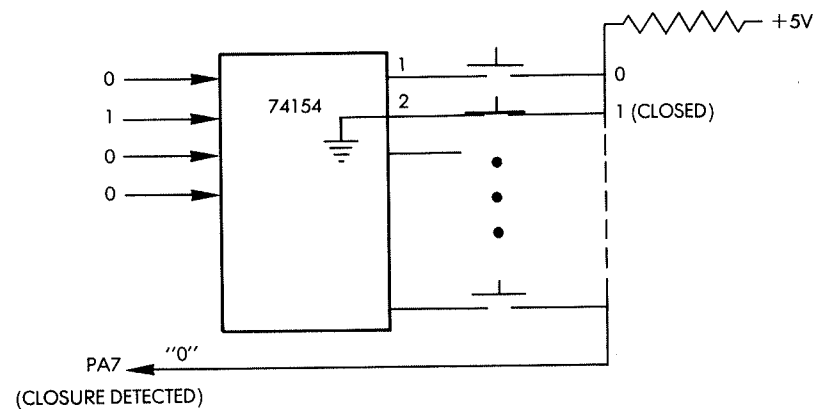

Fig. 1.10: Detecting a Key Closure

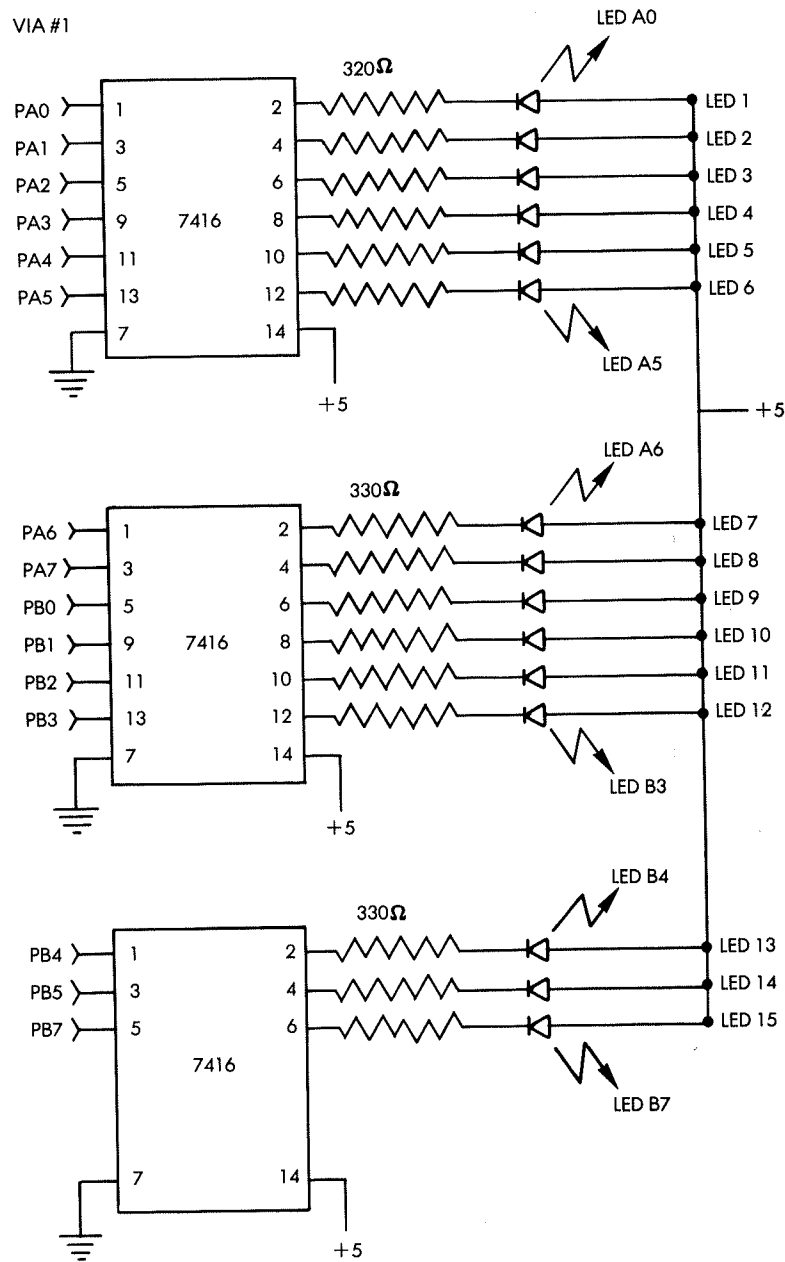

Fig. 1.11: LED Connection

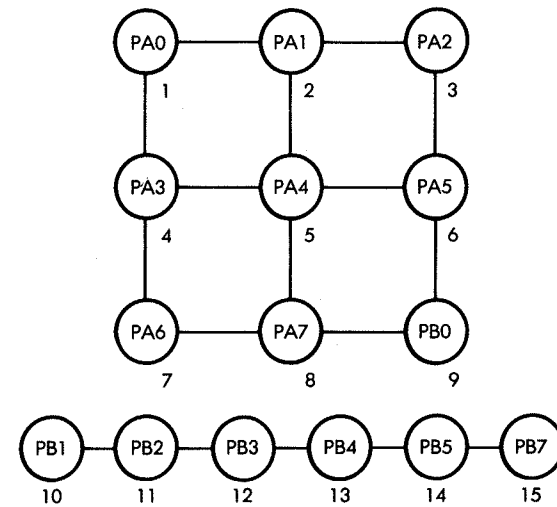

Fig. 1.12: LED Arrangement on the Board

The resistors shown in Figure 1.11 are 330-ohm resistors designed as current limiters for the 7416 gates.

The output routines will be described in the context of specific games.

Required Parts

- One 6" × 9" vector-board
- One 4-to-16 decoder (74154)
- Three inverting hex drivers (7416)
- One 24-pin socket
- Three 14-pin sockets (for the drivers)
- One 16-key keyboard, unencoded
- Fifteen 330-ohm resistors
- One 3.3 K-ohm resistor
- One decoupling capacitor (.1 mF)
- Fifteen LEDs
- One speaker
- One 50-ohm or 110-ohm resistor (for the speaker)
- Two 15"-20" long 16-conductor ribbon cables
- One package of wire-wrap terminal posts
- Wire-wrap wire
- Solder

A soldering iron and a wire-wrapping tool will also be required.

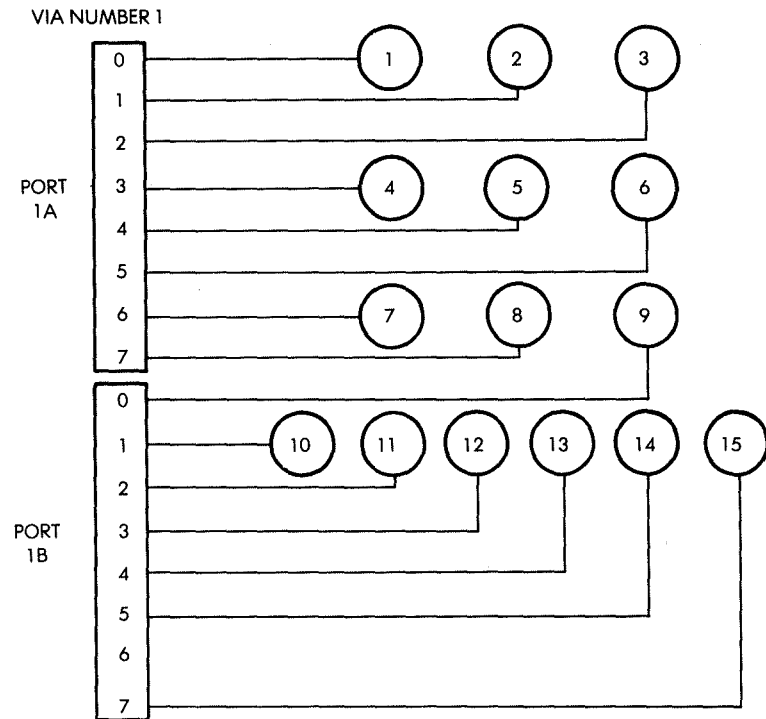

Fig. 1.13: Detail of LED Connection to the Ports

Assembly

A suggested assembly procedure is the following: the keyboard can be glued directly to the perf board. Sockets and LEDs can be positioned on the board and held in place temporarily with tape. All connections can then be wire-wrapped. In the case of the prototype, the connections to the keyboard were soldered in order to provide reliable connections since they were not designed as wire-wrap leads. Wire-wrap terminal posts were used for common connections.

Additionally, on the prototype two sockets were provided for convenience when attaching the ribbon cable connector to the Games Board. They are not indispensable, but their use is strongly suggested in order to be able to conveniently plug and unplug cables. (They appear in the top left corner of the photograph in Figure 1.14.) A 14-pin socket and a 16-pin socket are used for this purpose. Wire-wrap terminal posts can be used instead of these sockets to attach the ribbon cable directly to the perf board. The other end of the ribbon cable is

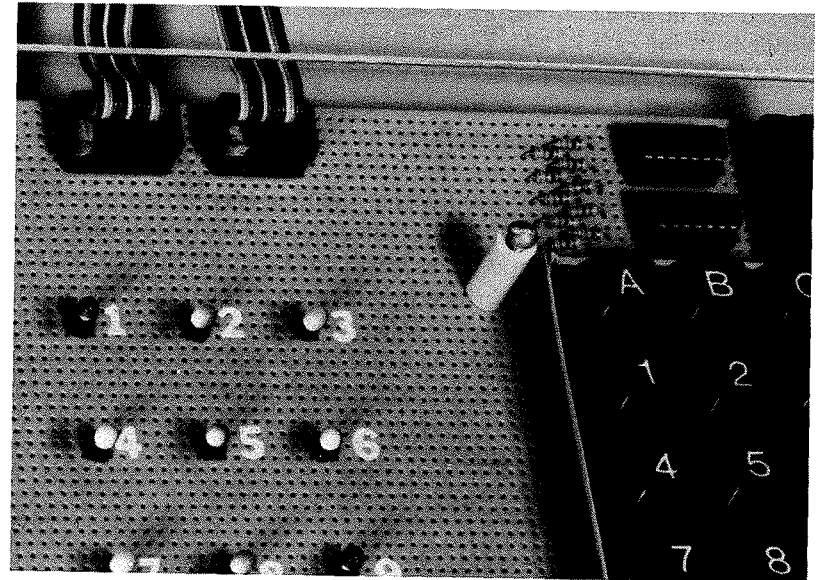

Fig. 1.14: Games Board Detail

simply attached to the edge connectors of the SYM. When connecting the ribbon cable at either end, always be very careful to connect it to the appropriate pins (do not connect it upside down). The Games Board derives its power from the SYM through the ribbon cable connection. Connecting the cable in reverse will definitely have adverse effects.

The speaker may be connected to any one of the output drivers PB4, PB5, PB6, or PB7 of VIA #3. Each of these output ports is equipped with a transistor buffer. A 110-ohm current-limiting resistor is inserted in series with the speaker.

The Keyboard Input Routine

This routine, called "GETKEY," is a utility routine which will scan the keyboard and identify the key that was pressed. The corresponding code will be contained in the accumulator. It has provisions for bounce, repeat, and rollover.

Keyboard bounce is eliminated by implementing a 50 ms delay upon detection of key closure.

The repeat problem is solved by waiting for the key currently

pressed to be released before a new value is accepted. This corresponds to the case in which a key is pressed for an extended period of time. Upon entering the GETKEY routine, a key might already be depressed. It will be ignored until the program detects that a key is no longer pressed. The program will then wait for the next key closure. If the processing program using the GETKEY routine performs long computations, there is a possibility that the user may push a new key on the keyboard before GETKEY is called again. This key closure will be ignored by GETKEY, and the user will have to press the key again.

Most of the programs described in this book have audible prompts in the form of a tone which is generated every time the player should respond. Note that when a tone is being generated or during a delay loop in a program, pressing a key will have absolutely no effect.

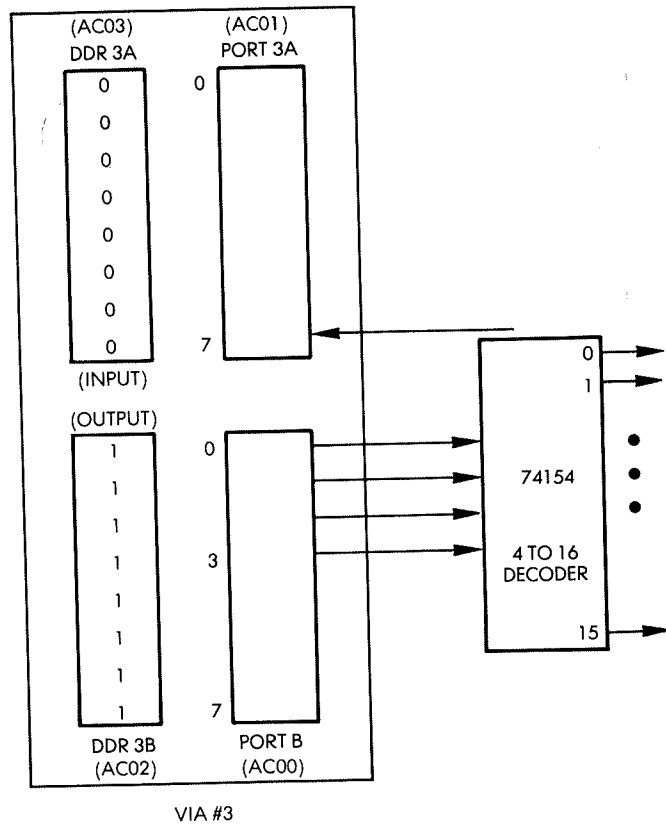

Fig. 1.15: VIA Connection to Keyboard Decoder

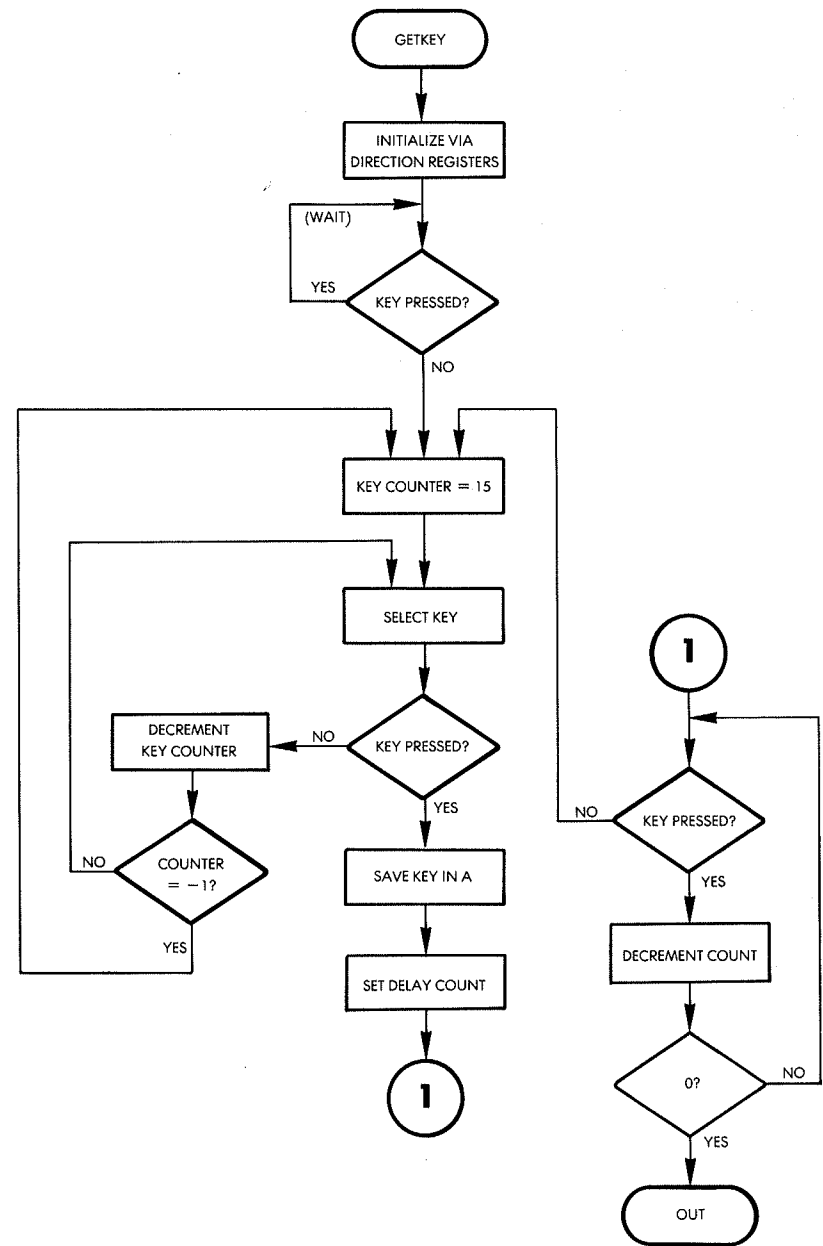

Fig. 1.16: GETKEY Flowchart

The hardware configuration for the GETKEY routine is shown in Figure 1.9. The corresponding input/output chip on the SYM is shown in Figure 1.15. VIA #3 of the SYM board is used to communicate with the keyboard. Port B of the VIA is configured for output and lines 0 through 3 are gated to the 74154 (4-to-16 decoder), connected to the keyboard itself. The GETKEY routine will output the hexadecimal numbers "0" through "F," in sequence, to the 74154. This will result in the grounding of the corresponding output line of the 74154. If a key is pressed, bit 7 of VIA #3 of Port A will be grounded. The program logic is, therefore, quite simple, and the corresponding flowchart is shown in Figure 1.16.

The program is shown in Figure 1.17. Let us examine it. The GETKEY routine can be relocated, i.e., it may be put anywhere in the memory. In order to conserve space, it has been located at memory locations 100 to 12E. It is important to remember that this is the low stack memory area. Any user programs which might require a full stack would overwrite this routine and thus destroy it. To prevent this possibility, it could be located elsewhere. For all of the programs that will be developed in this book, however, this placement is adequate. The first four instructions of the routine condition the data direction registers of VIA #3. The data direction register for Port A is set for input (all zeroes), while the data direction register for Port B is set for output (all ones). This is illustrated in Figure 1.15.

```
LDA #0
STA DDR3A
LDA #$FF
STA DDR3B
```

Two instructions are required to test bit 7 of Port 3A, which indicates whether a key closure has occurred:

```
START   BIT PORT3A
        BPL START
```

The key counter is initially set to the value 15, and will be decremented until a key closure is encountered. Index register X is used to contain this value, as it can readily be decremented with the DEX instruction:

```
RSTART  LDX #15
```

This value (15) is then output to the 74154 and results in the selection

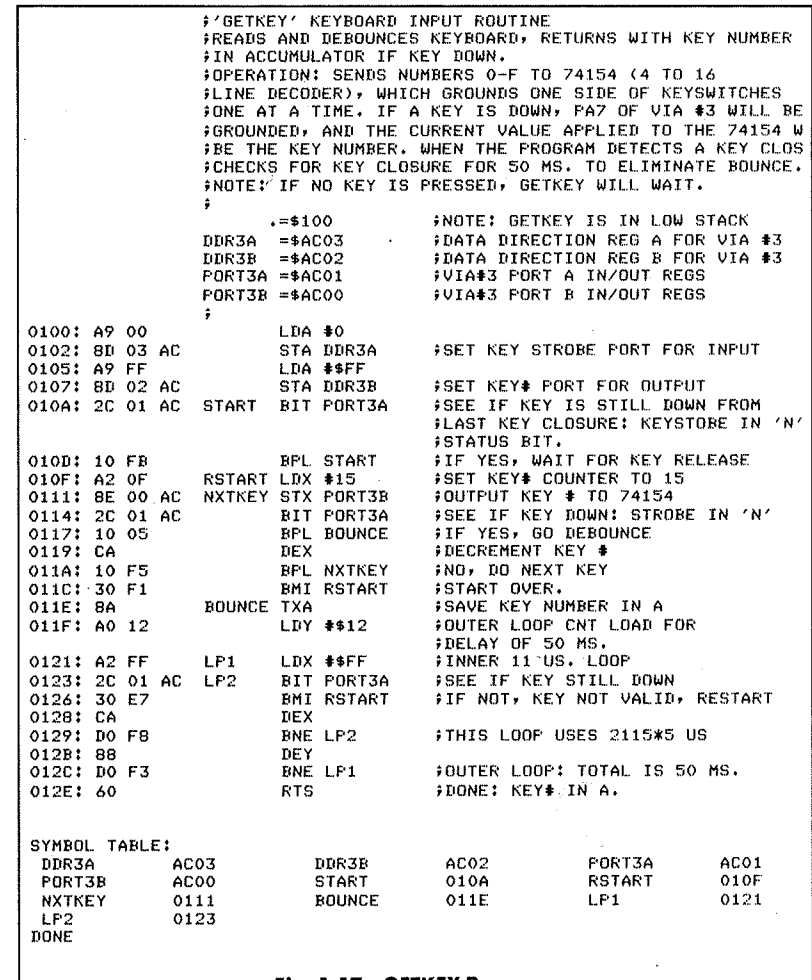

Fig. 1.17: GETKEY Program

of line 17 connected to key 15 ("F"). The BIT instruction above is used to test the condition of bit 7 of Port 3A to determine whether this key has been pressed.

```
NXTKEY  STX PORT3B
        BIT PORT3A
        BPL BOUNCE
```

If the key were closed, a branch would occur to "BOUNCE," and a

delay would be implemented to debounce it; otherwise, the counter is decremented, then tested for underflow. As long as the counter does not become negative, a branch back occurs to location NXTKEY. This loop is repeated until a key is found to be depressed or the counter becomes negative. In that case, the routine loops back to location RSTART, restarting the process:

```
DEX
BPL NXTKEY
BMI RSTART
```

Note that this will result in the detection of the highest key pressed in the case in which several keys are pressed simultaneously. In other words, if keys "F" and "3" were pressed simultaneously, key "F" would be identified as depressed, while key "3" would be ignored. Avoiding this problem is called *multiple-key rollover protection* and will be suggested as an exercise:

Exercise 1-1: *In order to avoid the multiple-key rollover problem, modify the GETKEY routine so that all 15 key closures are monitored. If more than one key is pressed, the key closure is to be ignored until only one key closure is sensed.*

Once the key closure has been identified, the corresponding key number is saved in the accumulator. A delay loop is then implemented in order to provide a 50 ms debouncing time. During this loop, the key closure is constantly monitored. If the key is released, the routine is restarted. The delay itself is implemented using a standard two-level, nested loop technique.

```
BOUNCE    TXA
          LDY #$12
LP1       LDX #$FF
LP2       BIT PORT3A
          BMI RSTART
          DEX
          BNE LP2
          DEY
          BNE LP1
```

Exercise 1-2: *The value used for the outer loop counter ("12," or 12 hexadecimal) may not be quite accurate. Compute the exact duration*

of the delay implemented by the instructions above, using the tables showing the duration of each instruction in the Appendix.

SUMMARY

Executing the games programs requires a simple Games Board which provides the basic input/output facilities. The required hardware and software interface has been described in this chapter. Photographs of the assembled board which evolved from the prototype are shown in Figures 1.18 and 1.19.

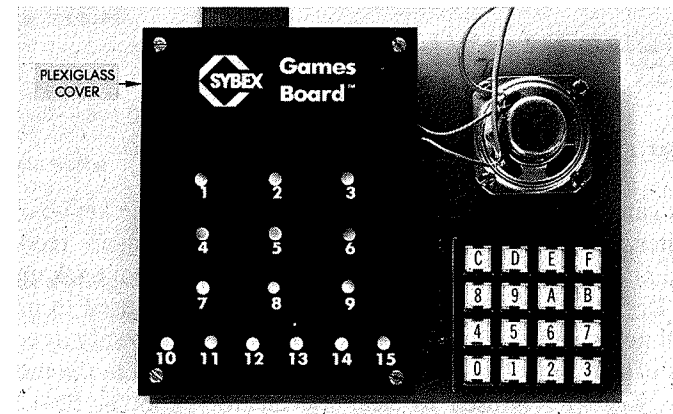

Fig. 1.18: "Production" Games Board

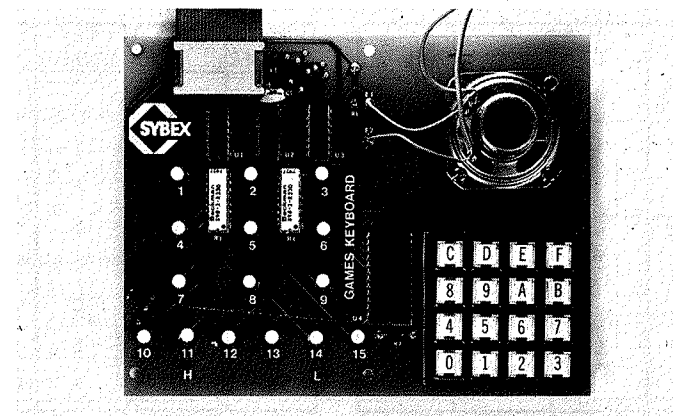

Fig. 1.19: Removing the Cover

2

MUSIC PLAYER

THE RULES

This game allows music to be played directly on the keyboard of a computer. In addition, the program will simultaneously record the notes that are played, and then automatically play them back upon request. Keys "0" through "C" on the keyboard are used to play the musical notes. (See Figure 2.1.) Key "D" is used to specify a rest. Key "E" is used to play back the musical sequence stored in the memory. Finally, key "F" is used to clear the memory, i.e., to start a new game. The following paragraph will describe the usual sequence of the game.

| A (A) | B (B) | C (C) | D (REST) |
|-----------|----------|-----------|-------------|
| 1 (A) | 2 (B) | 3 (C) | E (PBK) |
| 4 (D) | 5 (E) | 6 (F) | F (RST) |
| 7 (F#) | 8 (G) | 9 (G#) | 0 (G) |

| KEY NUMBER | NOTE | KEY NUMBER | NOTE |
|---------------|------|---------------|--------------|
| 0 | G | 8 | G |
| 1 | A | 9 | G# |
| 2 | B | A | A |
| 3 | C | B | B |
| 4 | D | C | C |
| 5 | E | D | REST |
| 6 | F | E | PLAY BACK |
| 7 | F# | F | RESTART |

Fig. 2.1: Playing Music on the Keyboard

9th Symphony:

5-5-6-8-8-6-5-4-3-3-4-5-5-4-4-D-5-
 5-6-8-8-6-5-4-3-3-4-5-4-3-3-D-4-4-
 5-3-4-6-5-3-4-6-5-4-3-4-D

Clementine:

3-3-3-D-2-D-5-5-5-D-3-D-3-5-8-D-D-
 8-6-5-4-D-D-D-4-5-6-D-6-D-5-4-5-D-
 3-D-3-5-4-D-D-2-3-4-3

Frere Jacques:

3-4-5-3-3-4-5-3-5-6-8-D-5-6-8-D-8-
 A-8-6-5-D-3-D-8-A-8-6-5-D-3-D-3-D-
 2-D-3-D-D-D-3-D-2-D-3

Jingle Bells:

5-5-5-D-5-5-5-D-5-8-3-4-5-D-D-D-6-
 6-6-6-6-5-5-5-8-8-6-4-3

London Bridge:

8-A-8-6-5-6-8-D-4-5-6-D-5-6-8-D-8-
 A-8-6-5-6-8-D-4-D-8-D-5-3

Mary Had a Little Lamb:

5-4-3-4-5-5-5-D-4-4-4-D-5-8-8-D-5-
 4-3-4-5-5-5-5-4-4-5-4-3

Row Row Row Your Boat:

3-D-3-D-3-4-5-D-5-4-5-6-8-D-D-D-C-
 C-8-8-5-5-3-3-8-6-5-4-3

Silent Night:

8-D-D-A-8-D-5-D-D-D-8-D-D-A-8-D-5-
 D-D-D-3-D-D-3-D-B-D-D-D-C-D-D-C-
 D-8-D-D-C-D-8-5-8-D-6-D-4-D-3

Twinkle Twinkle Little Star:

3-3-8-8-A-A-8-D-6-6-5-5-4-4-3-D-8-
 8-6-6-5-5-4-D-3-3-8-8-A-A-8-D-6-6-
 5-5-4-4-3

Fig. 2.2: Simple Tunes for Computer Music

A TYPICAL GAME

Press key "F" to start a new game. A three-note warble will be heard, confirming that the internal memory has been erased. Play the tune on keys "0" through "D" (using the notes and the rest features). Up to 254 notes may be played and stored in the memory. At any point, the playback key ("E") may be pressed and the notes and rests that were just played on the keyboard (and simultaneously stored in the memory) will be reproduced. The musical sequence may be played as many times as desired by simply pressing key "E." Examples of simple tunes or musical sequences that can be played on the computer are shown in Figure 2.2.

THE CONNECTIONS

This game uses the keyboard plus the speaker. The speaker is connected in series to one of the buffered output lines of PORT B of VIA #3, via a 110-ohm current limiting resistor. PB4, PB5, PB6, or PB7 of VIA #3 are used, as they are driven by a transistor buffer on the SYM. For higher quality music, it is recommended that the speaker be placed in a small box-type enclosure. The value of the resistor may also be adjusted for louder volume (without going below 50-ohm) to limit the current in the transistor.

THE ALGORITHM

A tone (note) is simply generated by sending a square wave of the appropriate frequency to the speaker, i.e., by turning it on and off at the required frequency. This is illustrated in Figure 2.3. The length of time during which the speaker is on or off is known as the half-period. In this program, the frequency range of 195 to 523 Hertz is provided. If N is the frequency, the period T is the inverse of the frequency, or:

$$T = 1/N$$

Therefore, the half-periods will range from $1/(2 \times 195) = .002564$ to

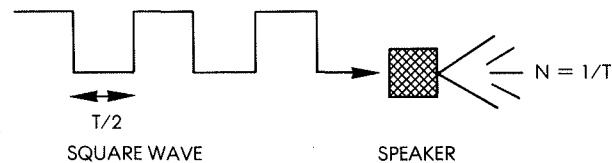

Fig. 2.3: Generating a Tone

$1/(2 \times 523) = .000956$ microseconds. A classic loop delay will be used to implement the required frequency.

Actual computations for the various program parameters will be presented below.

THE PROGRAM

The program is located at memory addresses 200 through 2DD, and the recorded musical sequence or tune is stored starting at memory location 300. Up to 254 notes may be recorded in 127 bytes.

Data Structures

Three tables are used in this program. They are shown in Figure 2.4. The recorded tune is stored in a table starting at address 300. The note constants, used to establish the frequency at which the speaker will be toggled, are stored in a 16-byte table located at memory address 2C4. The note durations, i.e., the number of half-cycles required to implement a uniform note duration of approximately .21 second, are stored in a 16-byte table starting at memory address 2D1. Within the tune table, two "nibble"-pointers are used: PILEN during input and PTR during output. (Each 8-bit byte in this table contains two notes.) In order to obtain the actual table entry from the nibble-pointer, the pointer is simply shifted one bit position to the right. The remaining value becomes a byte-pointer, while the bit shifted into the carry flag specifies the left or the right half of the byte. The two tables called CONSTANTS and NOTE DURATIONS are simply reference tables used to determine the half-frequency of a note and the number of times the speaker should be triggered once a note has been identified or specified. Both of these tables are accessed indirectly using the X register.

Some Music Theory

A brief survey of general music conventions is in order before describing the actual program. The frequencies used to generate the desired notes are derived from the equally tempered scale, in which the frequencies of succeeding notes are in the ratio:

$$1 : \sqrt[12]{2}$$

The frequencies for the middle C octave are given in Figure 2.5. When computing the corresponding frequencies of the higher or the

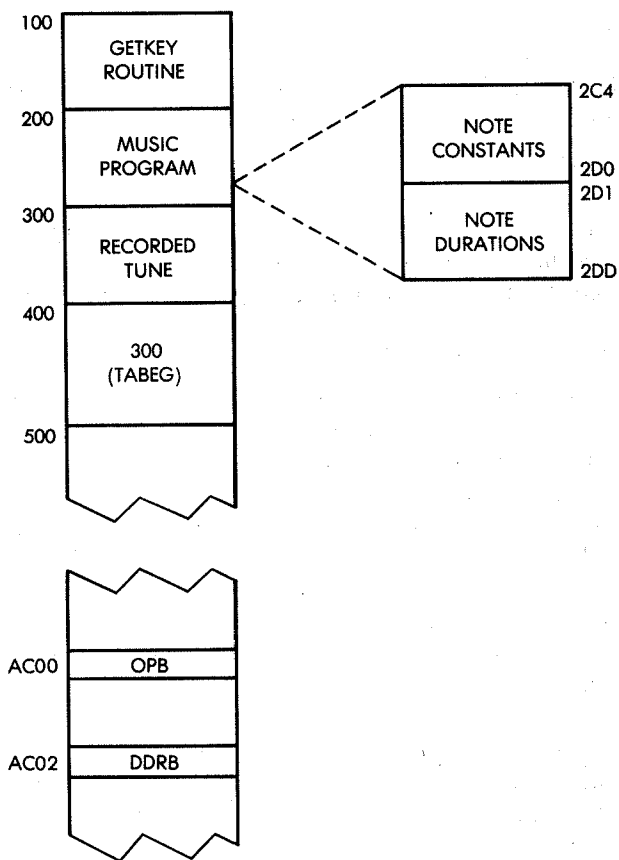

Fig. 2.4: Memory Map

lower octave, they are simply obtained by multiplying by two, or dividing by two, respectively.

Generating the Tone

The half-period delay for the square wave sent to the speaker is implemented using a program loop with a basic 10 μs cycle time. In the program, the “loop index,” or iteration counter is used to count the number of 10 μs cycles executed. The loop will result in a total delay of:

$$(\text{loop index}) \times 10 - 1 \text{ microseconds}$$

| NOTE | FREQUENCY (HERTZ) |
|------|-------------------|
| A | 220.00 |
| A# | 223.08 |
| B | 246.94 |
| C | 261.62 |
| C# | 277.18 |
| D | 293.66 |
| D# | 311.13 |
| E | 329.63 |
| F | 349.23 |
| F# | 369.99 |
| G | 391.99 |
| G# | 415.30 |

Fig. 2.5: Frequencies for the Middle C Octave

On the last iteration of the loop (when the loop index is decremented to zero), the branch instruction at the end will fail. This branch instruction will execute faster, so that one microsecond (assuming a 1 MHz clock) must be subtracted from the total delay duration. The tone generation routine is shown below:

```

TONE      STA  FREQ
          LDA  #$FF
          STA  DDRB
          LDA  #$00
          LDX  DUR
          LDY  FREQ
FL2       DEY
FL1       CLC
          BCC  .+2
          BNE  FL1
          EOR  #$FF
          STA  OPB
          DEX
          BNE  FL2
          RTS
    
```

} INNER LOOP
} OUTER LOOP

Note the “classic” nested loop design. Every time it is entered, the outer loop adds an additional thirteen microseconds delay: 14 microseconds for the extra instructions (LDY, EOR, STA, DEX, and

BNE), minus one microsecond for responding to the unsuccessful inner loop branch. The total outer loop delay introduced is therefore:

$$(\text{loop index}) \times 10 + 13 \text{ microseconds}$$

Remember that one pass through the outer loop represents only a half-period for the note.

Computing the Note Constants

Let "ID" be the inner loop delay and "OD" be the outer loop additional delay. It has been established in the previous paragraph that the half-period is $T/2 = (\text{loop index}) \times 10 + 13$ or,

$$T/2 = (\text{loop index}) \times ID + OD$$

The note constant stored in the table is the value of the "index" required by the program. It is easily derived from the equation that:

$$\text{note constant} = \text{loop index} = (T - 2 \times OD)/2 \times ID$$

The period may be expressed in function of the frequency as $T = 1/N$ or, in microseconds:

$$T = 10^6/N$$

Finally, the above equation becomes:

$$\text{note constant} = (10^6/N - 2 \times OD)/2 \times ID$$

For example, let us compute the note constant corresponding to the frequency for middle C. The frequency corresponding to middle C is shown in Figure 2.5. It is 261.62 Hertz. The "OD" delay has been shown above to be 13 microseconds, while "ID" was set to 10 microseconds. The note constant equation becomes:

$$\begin{aligned} \text{note constant} &= (10^6/N - 2 \times 13)/2 \times 10 \\ &= \frac{1000000/261.62 - 26}{20} \\ &= 190 \text{ (or BE in hexadecimal)} \end{aligned}$$

It can be verified that this corresponds to the fourth entry in the table

| NOTE | | NOTE | CONSTANT | NOTE | CONSTANT | | | |
|-------------------|-------------|----------------|----------|------|----------|-------------------|---|----|
| BELOW MIDDLE C | G A B | FE E2 C9 | MIDDLE C | C | BE | ABOVE MIDDLE C | C | 5E |
| | | | | D | A9 | | | |
| | | | | E | 96 | | | |
| | | | | F | 8E | | | |
| | | | | F# | 86 | | | |
| | | | | G | 7E | | | |
| | | | | G# | 77 | | | |
| | | | | A | 70 | | | |
| B | 64 | | | | | | | |

Fig. 2.6: Note Constants

at address NOTAB (see Figure 2.9 at the end of the listing, at address 02C4). The note constants are shown in Figure 2.6.

Exercise 2-1: Using the table in Figure 2.6, compute the corresponding frequency, and check to see if the constants have been chosen correctly.

Computing the Note Durations

The DURTAB table stores the note durations expressed in numbers equivalent to the number of half-cycles for each note. These durations have been computed to implement a uniform duration of approximately .2175 second per note. If D is the duration and T is the period, the following equation holds:

$$D \times T = .2175$$

where D is expressed as a number of periods. Since, in practice, half-periods are used, the required number D' of half-periods is:

$$D' = 2D = 2 \times .2175 \times N$$

For example, in the case of the middle C:

$$D = 2 \times .2175 \times 261.62 = 133.8 \approx 114 \text{ decimal (or 72 hexadecimal)}$$

Exercise 2-2: Compute the note durations using the equation above, and the frequency table in Figure 2.5 (which needs to be expanded). Verify that they match the numbers in table DURTAB at address 2D1. (See Figure 2.9)

Program Implementation

The program has been structured in two logical parts. The corresponding flowchart is shown in Figure 2.7. The first part of the program is responsible for collecting the notes and begins at label

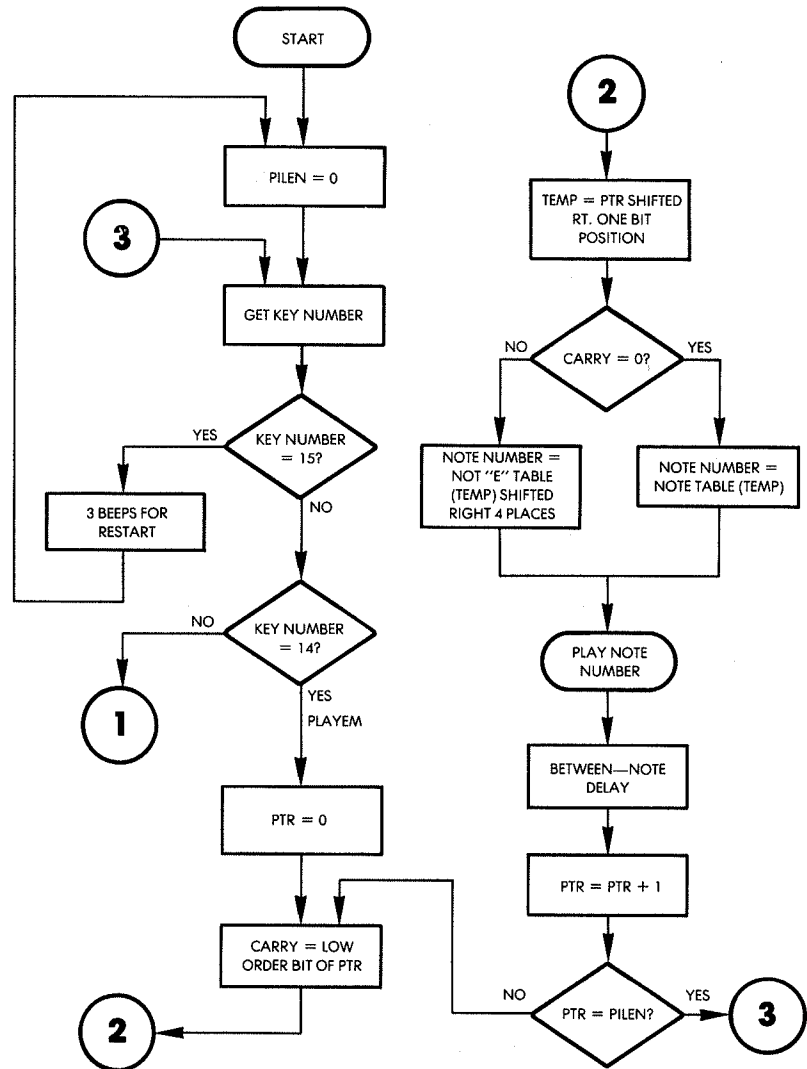

Fig. 2.7: Music Flowchart

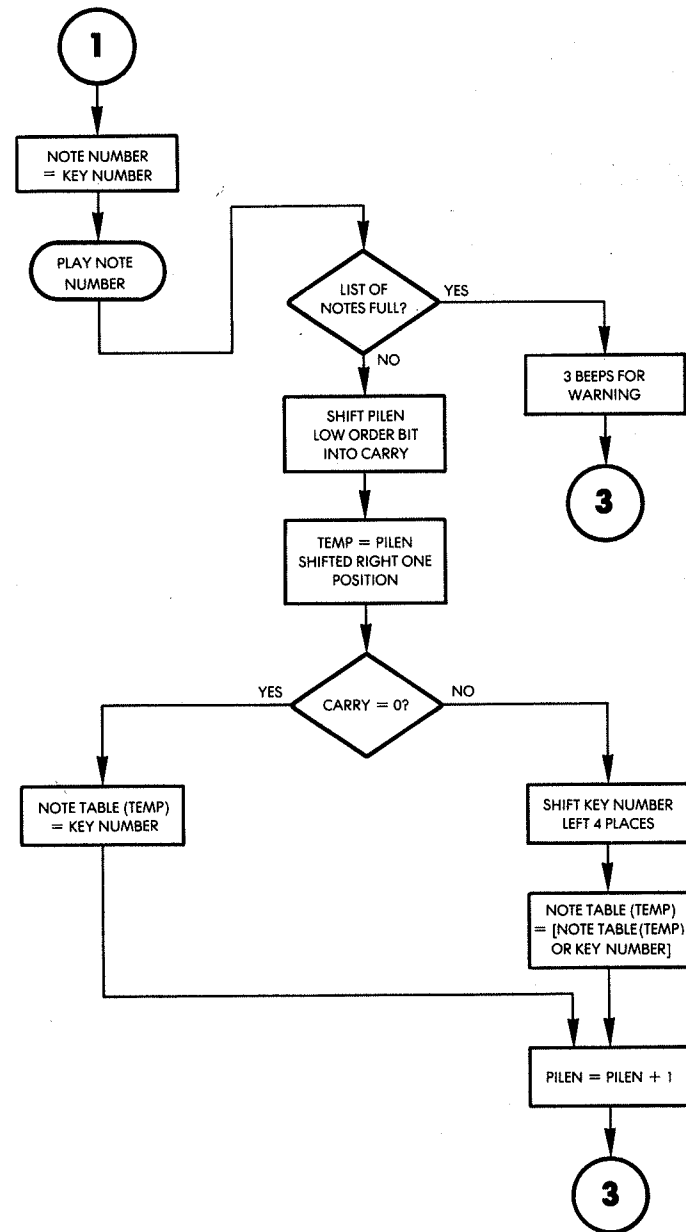

Fig. 2.7: Music Flowchart (Continued)

“NUMKEY.” (The program is shown in Figure 2.9). The second part begins at the label “PLAYEM” and its function is to play the stored notes. Both parts of the program use the PLAYNOTE subroutine which looks up the note and duration constants, and plays the note. This routine begins at the label “PLAYIT,” and its flowchart is shown in Figure 2.8.

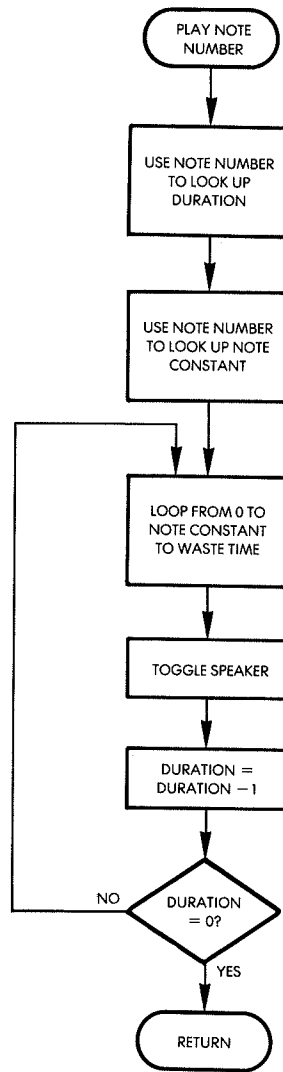

Fig. 2.8: PLAYIT Flowchart

```

; MUSIC PLAYER PROGRAM
; USES 16 - KEY KEYBOARD AND BUFFERED SPEAKER
; PROGRAM PLAYS STORED MUSICAL NOTES.
; THERE ARE TWO MODES OF OPERATION: INPUT AND PLAY.
; INPUT MODE IS THE DEFAULT, AND ALL NON-COMMAND KEYS
; PRESSED (O-D) ARE STORED FOR REPLAY. IF AN OVERFLOW
; OCCURS, THE USER IS WARNED WITH A THREE-TONE WARNING.
; THE SAME WARBLING TONE IS ALSO USED TO SIGNAL A
; RESTART OF THE PROGRAM.
;
GETKEY = $100
FILEN = $00 ;LENGTH OF NOTE LIST
TEMP = $01 ;TEMPORARY STORAGE
PTR = $02 ;CURRENT LOCATION IN LIST
FREQ = $03 ;TEMPORARY STORAGE FOR FREQUENCY
DUR = $04 ;TEMP STORAGE FOR DURATION
TABEG = $300 ;TABLE TO STORE MUSIC
OPB = $AC00 ;VIA OUTPUT PORT B
DDRB = $AC02 ;VIA PORT B DIRECTION REGISTER
, = $200 ;ORIGIN
;
; COMMAND LINE INTERPRETER
; $F AS INPUT MEANS RESET POINTERS, START OVER.
; $E MEANS PLAY CURRENTLY STORED NOTES
; ANYTHING ELSE IS STORED FOR REPLAY.
;
START LDA #0 ;CLEAR NOTE LIST LENGTH
0202: 85 00 STA FILEN
0204: 18 CLC ;CLEAR NIBBLE MARKER
0205: 20 00 01 NXKEY JSR GETKEY
0208: C9 0F CMP #15 ;IS KEY #15?
020A: D0 05 BNE NXTST ;NO, DO NEXT TEST
020C: 20 87 02 JSR BEEP3 ;TELL USER OF CLEARING
020F: 90 EF BCC START ;CLEAR POINTERS AND START OVER
0211: C9 0E NXTST CMP #14 ;IS KEY #14?
0213: D0 06 BNE NUMKEY ;NO, KEY IS NOTE NUMBER
0215: 20 48 02 JSR PLAYEM ;PLAY NOTES
0218: 18 CLC
0219: 90 EA BCC NXKEY ;GET NEXT COMMAND
;
; ROUTINE TO LOAD NOTE LIST WITH NOTES
;
NUMKEY STA TEMP ;SAVE KEY, FREE A
021D: 20 70 02 JSR PLAYIT ;PLAY NOTE
0220: A5 00 LDA FILEN ;GET LIST LENGTH
0222: C9 FF CMP #$FF ;OVERFLOW?
0224: D0 05 BNE OK ;NO, ADD NOTE TO LIST
0226: 20 87 02 JSR BEEP3 ;YES, WARN USER
0229: 90 DA BCC NXKEY ;RETURN TO INPUT MODE
022B: 4A LSR A ;SHIFT LOW BIT INTO NIBBLE POINTER
022C: A8 TAY ;USE SHIFTED NIBBLE POINTER AS
; BYTE INDEX
022D: A5 01 LDA TEMP ;RESTORE KEY#
022F: B0 09 BCS FINBYT ;IF BYTE ALREADY HAS 1 NIBBLE,
; FINISH IT AND STORE
0231: 29 0F AND #%00001111 ;1ST NIBBLE, MASK HIGH NIBBLE
0233: 99 00 03 STA TABEG,Y ;SAVE UNFINISHED 1/2 BYTE
0236: E6 00 INC FILEN ;POINT TO NEXT NIBBLE
0238: 90 CB BCC NXKEY ;GET NEXT KEYSTROKE
023A: 0A FINBYT ASL A ;SHIFT NIBBLE 2 TO HIGH ORDER
023B: 0A ASL A
023C: 0A ASL A
023D: 0A ASL A
023E: 19 00 03 ORA TABEG,Y ;JOIN 2 NIBBLES AS BYTE
0241: 99 00 03 STA TABEG,Y ;...AND STORE.
0244: E6 00 INC FILEN ;POINT TO NEXT NIBBLE IN NEXT BYTE
0246: 90 BD BCC NXKEY ;RETURN
  
```

Fig. 2.9: Music Program

```

;
; ROUTINE TO PLAY NOTES
;
0248: A2 00   PLAYEM LDX #0       ;CLEAR POINTER
024A: B6 02   STX PTR
024C: A5 02   LDA PTR       ;LOAD ACUM W/CURRENT PTR VAL
024E: 4A     LOOP LSR A       ;SHIFT NIBBLE INDICATOR INTO CARRY
024F: AA     TAX             ;USE SHIFTED NIBBLE POINTER
                        ;AS BYTE POINTER
0250: BD 00 03   LDA TABEG,X    ;LOAD NOTE TO PLAY
0253: B0 04   BCS ENDBYT    ;LOW NIBBLE USED, GET HIGH
0255: 29 0F   AND #%00001111 ;MASK OUT HIGH BITS
0257: 90 06   BCC FINISH    ;PLAY NOTE
0259: 29 F0   ENDBYT AND #%11110000 ;THROW AWAY LOW NIBBLE
025B: 4A     LSR A         ;SHIFT INTO LOW
025C: 4A     LSR A
025D: 4A     LSR A
025E: 4A     LSR A
025F: 20 70 02 FINISH JSR PLAYIT ;CALCULATE CONSTANTS & PLAY
0262: A2 20   LDX #20       ;BETWEEN-NOTE DELAY
0264: 20 9C 02 JSR DELAY
0267: E6 02   INC PTR       ;ONE NIBBLE USED
0269: A5 02   LDA PTR
026B: C5 00   CMP PILEN    ;END OF LIST?
026D: 90 DF   BCC LOOP     ;NO, GET NEXT NOTE
026F: 60     RTS           ;DONE

;
;ROUTINE TO DO TABLE LOOK UP, SEPARATE REST
;
0270: C9 0D   PLAYIT CMP #13   ;REST?
0272: D0 06   BNE SOUND    ;NO,
0274: A2 54   LDX #54     ;DELAY=NOTE LENGTH=.21SEC
0276: 20 9C 02 JSR DELAY
0279: 60     RTS
027A: AA     SOUND TAX      ;USE KEY# AS INDEX..
027B: BD D1 02 LDA DURTAB,X ;...TO FIND DURATION.
027E: B5 04   STA DUR      ;STORE DURATION FOR USE
0280: BD C4 02 LDA NOTAB,X  ;LOAD NOTE VALUE
0283: 20 AB 02 JSR TONE
0286: 60     RTS

;
;ROUTINE TO MAKE 3 TONE SIGNAL
;
0287: A9 FF   BEEP3 LDA #FF   ;DURATION FOR BEEPS
0289: B5 04   STA DUR
028B: A9 4B   LDA #4B     ;CODE FOR E2
028D: 20 AB 02 JSR TONE    ;1ST NOTE
0290: A9 3B   LDA #3B     ;CODE FOR D2
0292: 20 AB 02 JSR TONE
0295: A9 4B   LDA #4B
0297: 20 AB 02 JSR TONE
029A: 18     CLC
029B: 60     RTS

;
;VARIABLE-LENGTH DELAY
;
029C: A0 FF   DELAY LDY #FF
029E: EA     DLY NOP
029F: D0 00   BNE ,+2
02A1: 8B     DEY
02A2: D0 FA   BNE DLY     ;10 US LOOP
02A4: CA     DEX
02A5: D0 F5   BNE DELAY  ;LOOP TIME = 255*(A)+26 US
02A7: 60     RTS

;
;ROUTINE TO MAKE TONE: # OF 1/2 CYCLES IS IN 'DUR',
;AND 1/2 CYCLE TIME IS IN A. LOOP TIME=20*(A)+26 US

```

Fig. 2.9: Music Program (Continued)

```

;SINCE TWO RUNS THROUGH THE OUTER LOOP MAKES
;ONE CYCLE OF THE TONE,
;
02A8: B5 03   TONE STA FREQ   ;FREQ IS TEMP FOR # OF CYCLES
02AA: A9 FF   LDA #FF     ;SET UP DATA DIRECTION REG
02AC: 8D 02 AC STA DDRB
02AF: A9 00   LDA #00     ;A IS SENT TO PORT, START HI
02B1: A6 04   LDX DUR
02B3: A4 03   FL2 LDY FREQ
02B5: 88     FL1 DEY
02B6: 18     CLC
02B7: 90 00   BCC ,+2
02B9: D0 FA   BNE FL1     ;INNER, 10 US LOOP
02BB: 49 FF   EOR #FF     ;COMPLEMENT I/O PORT
02BD: 8D 00 AC STA OPB    ;...AND SET IT
02C0: CA     DEX
02C1: D0 F0   BNE FL2    ;OUTER LOOP
02C3: 60     RTS

;TABLE OF NOTE CONSTANTS
;CONTAINS:
;[OCTAVE BELOW MIDDLE C] : G,A,B
;[OCTAVE OF MIDDLE C] : C,D,E,F,G,A,B
;[OCTAVE ABOVE MIDDLE C] : C
;
02C4: FE     NOTAB .BYT $FE,$E2,$C9,$BE,$A9,$96,$BE
02C5: E2
02C6: C9
02C7: BE
02C8: A9
02C9: 96
02CA: 8E
02CB: 86     .BYT $86,$7E,$77,$70,$64,$5E
02CC: 7E
02CD: 77
02CE: 70
02CF: 64
02D0: 5E

;TABLE OF NOTE DURATIONS IN # OF 1/2 CYCLES
;SET FOR A NOTE LENGTH OF ABOUT .21 SEC.
;
02D1: 55     DURTAB .BYT $55,$60,$6B,$72,$80,$8F,$94
02D2: 60
02D3: 6B
02D4: 72
02D5: 80
02D6: 8F
02D7: 94     .BYT $A1,$AA,$B5,$BF,$D7,$E4
02D8: A1
02D9: AA
02DA: B5
02DB: BF
02DC: D7
02DD: E4

SYMBOL TABLE:
GETKEY 0100 FILEN 0000 TEMP 0001
PTR 0002 FREQ 0003 DUR 0004
TABEG 0300 OPB AC00 DDRB AC02
START 0200 NXKEY 0205 NXTST 0211
NUMKEY 021B OK 022B FINBYT 023A
PLAYEM 0248 LOOP 024E ENDBYT 0259
FINISH 025F PLAYIT 0270 SOUND 027A
BEEP3 0287 DELAY 029C DLY 029E
TONE 02A8 FL2 02B3 FL1 02B5
NOTAB 02C4 DURTAB 02D1
%
```

Fig. 2.9: Music Program (Continued)

The main routines are called, respectively, NXKEY, NUMKEY, and BEEP3 for the note-collecting program, and PLAYEM and DELAY for the note-playing program. Finally, common utility routines are TONE and PLAYIT.

Let us examine these routines in greater detail. The program resides at memory addresses 200 and up. Note that the program, like most others in this book, assumes the availability of the GETKEY routine described in Chapter 1.

The operation of the NXKEY routine is straightforward. The next key closure is obtained by calling the GETKEY routine:

```

START      LDA #0
           STA PILEN      Initialize length of list to 0
           CLC
NXKEY      JSR GETKEY

```

The value read is then compared to the constants "15" and "14" for special action. If no match is found, the constant is stored in the note list using the NUMKEY routine.

```

           CMP #15
           BNE NXTST
           JSR BEEP3
           BCC START
NXTST      CMP #14
           BNE NUMKEY
           JSR PLAYEM
           CLC
           BCC NXKEY

```

Exercise 2-3: *Why are the last two instructions in this routine used instead of an unconditional jump? What are the advantages and disadvantages of this technique?*

Every time key number 15 is pressed, a special three-tone routine called BEEP3 is played. The BEEP3 routine is shown at address 0287. It plays three notes in rapid succession to indicate to the user that the notes in the memory have been erased. The erasure is performed by resetting the list length PILEN to zero. The corresponding routine appears below:

```

BEEP3      LDA #$FF      Beep duration constant
           STA DUR
           LDA #$4B      Code for E2
           JSR TONE      1st note
           LDA #$38      Code for D2
           JSR TONE      2nd note
           LDA #$4B      Code for E2
           JSR TONE      3rd note
           CLC
           RTS

```

Its operation is straightforward.

The NUMKEY routine will save the code corresponding to the note in the memory. As in the case of a Teletype program, the computer will echo the character which has been pressed in the form of an audible sound. In other words, every time a key has been pressed, the program will play the corresponding note. This is performed by the next two instructions:

```

NUMKEY     STA TEMP
           JSR PLAYIT

```

The list length is then checked for overflow. If an overflow situation is encountered, the player is advised through the use of the three-tone sequence of BEEP3:

```

           LDA PILEN      Get length of list
           CMP #$FF      Overflow?
           BNE OK        No: add note to list
           JSR BEEP3     Yes: warn player
           BCC NXKEY     Read next key

```

Otherwise, the new nibble (4 bits) corresponding to the note identification number is shifted into the list:

```

OK         LSR A          Shift low bit into
                       nibble pointer
           TAY           Use as byte index
           LDA TEMP      Restore key #

```

Note that the nibble-pointer is divided by two and becomes a byte index. It is then stored in register Y, which will be used later to perform

an indexed access to the appropriate byte location within the table (STA TABEG,Y).

Depending on the value which has been shifted into the carry bit, the nibble is stored either in the high end or in the low end of the table's entry. Whenever the nibble must be saved in the high-order position of the byte, a 4-bit shift to the left is necessary, which requires four instructions:

```

BCS FINBYT      Test if byte has a nibble
AND #%00001111  Mask high nibble
STA TABEG,Y     Save
INC PILEN       Next nibble
BCC NXKEY

FINBYT ASL A
      ASL A
      ASL A
      ASL A
  
```

Finally, it can be saved in the appropriate table address,

```

ORA TABEG,Y
STA TABEG,Y
  
```

The pointer is incremented and the next key is examined:

```

INC PILEN
BCC NXKEY
  
```

Let us look at this technique with an example. Assume:

```

PILEN = 9      (length of list)
TEMP = 6       (key pressed)
  
```

The effect of the instructions is:

```

OK      LSR A      A will contain 4, C will contain 1
        TAY        Y = 4
        LDA TEMP    A = 6
        BCS FINBYT C is 1 and the branch occurs
  
```

The situation in the list is:

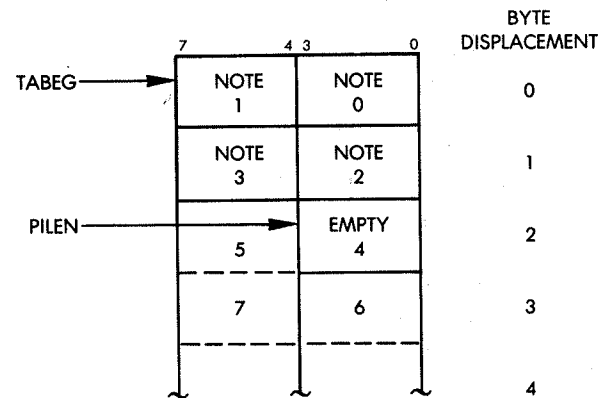

Fig. 2.10: Entering a Note in the List

Shift "6" into the high-order position of A:

```

FINBYT ASL A
      ASL A
      ASL A
      ASL A      A = 60 (hex)
  
```

Write A into table:

```

ORA TABEG,Y      A = 16X (where X is the previous nibble in the table)

STA TABEG,Y      Restore old nibble with new nibble
  
```

The Subroutines

PLAYEM Subroutine

The PLAYEM routine is also straightforward. The PTR memory location is used as the running nibble-pointer for the note table. As before, the contents of the running nibble-pointer are shifted to the right and become a byte pointer. The corresponding table entry is then loaded using an indexed addressing method:

```

PLAYEM   LDX #0
          STX PTR           PTR = 0
          LDA PTR
LOOP     LSR A
          TAX
          LDA TABEG,X
          BCS ENDBYT
          AND #%00001111
          BCC FINISH
ENDBYT  AND #%011110000
          LSR A
          LSR A
          LSR A
          LSR A

```

Depending upon the value of the bit which has been shifted into the carry, either the high-order nibble or the low-order nibble will be extracted and left-justified in the accumulator. The subroutine PLAYIT described below is used to obtain the appropriate constants and to play the note:

```

FINISH   JSR PLAY IT      Play note

```

A delay is then implemented between two consecutive notes, the running pointer is incremented, a check occurs for a possible end of list, and the loop is reentered:

```

          LDX #$20          Delay constant
          JSR DELAY        Delay between notes
          INC PTR          One nibble used
          LDA PTR
          CMP PILEN        Check for end of list
          BCC LOOP        No: get next note
          RTS              Done

```

PLAYIT Subroutine

The PLAYIT subroutine plays the note or implements a rest, as specified by the nibble passed to it in the accumulator. This subroutine is called "PLAYNOTE" on the program flowchart. It merely looks up the appropriate duration for the note from table DURTAB, and saves it at address DUR (at memory location 4). It then loads the appropriate half-period value from the table at address NOTAB into the

A register, using indexed addressing, and calls subroutine TONE to play it:

```

PLAYIT   CMP #13          Check for a rest
          BNE SOUND        No
          LDX #$54         Delay = .21 sec (note duration)
          JSR DELAY        If rest was specified
          RTS
SOUND    TAX              Use key # as index
          LDA DURTAB,X     To look up duration
          STA DUR
          LDA NOTAB,X
          JSR TONE
          RTS

```

TONE Subroutine

The TONE subroutine implements the appropriate wave form generation procedure described above, and toggles the speaker at the appropriate frequency to play the specified note. It implements a traditional two-level, nested loop delay, and toggles the speaker by complementing the output port after each specified delay has elapsed:

```

TONE     STA FREQ

```

A contains the half-cycle time on entry. It is stored in FREQ. The loop timing will result in an output wave-length of:

$$(20 \times A + 26) \mu s$$

Port B is configured as output:

```

          LDA #$FF
          STA DDRB

```

Registers are then initialized. A is set to contain the pattern to be output. X is the outer loop counter. It is set to the value DUR which contains the number of half cycles at the time the subroutine is called:

```

          LDA #$00
          LDX DUR

```

The inner loop counter Y is then initialized to `FREQ`, the frequency constant:

```
FL2      LDY FREQ
```

and the inner loop delay is generated as usual:

```
FL1      DEY
          CLC
          BCC .+2
          BNE FL1          10 μs inner loop
```

Then the output port is toggled by complementing it:

```
EOR #$FF
STA OPB
```

and the outer loop is completed:

```
DEX
BNE FL2
RTS
```

The `DELAY` subroutine is shown in Figure 2.9 at memory location 29C and is left as an exercise.

SUMMARY

This program uses a simple algorithm to remember and play tunes. All data and constants are stored in tables. Timing is implemented by nested loops. Indexed addressing techniques are used to store and retrieve data. Sound is generated by a square wave.

EXERCISES

Exercise 2-4: *Change the note constants to implement a different range of notes.*

Exercise 2-5: *Store a tune in memory in advance. Trigger it by pressing key "0."*

Exercise 2-6: *Rewrite the program so that it will store the note and duration constants in memory when they are entered, and will not need to look them up when the tune is played. What are the disadvantages of this method?*

3

TRANSLATE

THE RULES

This is a game designed for two competing players. Each player tries to quickly decipher the computer's coded numbers. The players are alternately given a turn to guess. Each player attempts to press the hexadecimal key corresponding to a 4-bit binary number displayed by the program. The program keeps track of the total guessing time for each player, up to a limit of about 17 seconds. When each player has correctly decoded a number, the players' response times are compared to determine who wins the turn. The first player to win ten turns wins the match.

The program signals each player's turn by displaying an arrow pointing either to the left or to the right. The player on the right will be signaled first to initiate the game. The program's "prompt" is shown in Figure 3.1.

A random period of time will elapse after this prompt, then the bottom row of LEDs on the Games Board will light up. The left-most LED (LED #10) signals to the player to proceed. The four right-most LEDs (LEDs 12, 13, 14, and 15) display the coded binary number. This is shown in Figure 3.2. In this case, player 1 should clearly press key number 5. If the player guesses correctly, the program switches to player 2. Otherwise, player 1 will be given another chance until his or her turn (17 seconds) is up. It should be noted here that for each number presented to the player, the total guessing time is accumulated to a maximum of about 17 seconds. When the maximum is reached, the bottom row will go blank and a new number will be displayed.

The program signals player 2's turn (the player on the left) by displaying a left arrow on the LEDs as shown in Figure 3.3. Once both players have had a turn to guess a binary digit, the program will signal

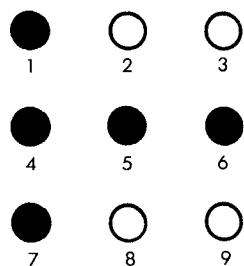

Fig. 3.1: Prompt Signals the Right Player to Play

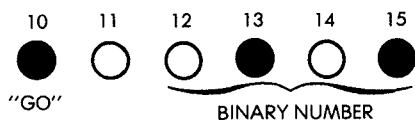

Fig. 3.2: Bottom Row of LEDs Displays Number to be Guessed

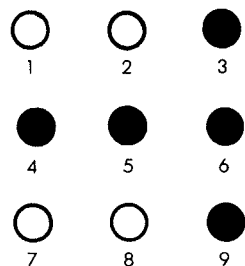

Fig. 3.3: It is Player 2's Turn (Left Player)

the winner by lighting up either the left-most or the right-most three LEDs of the bottom row. The winner is the player with the shortest guessing time. The game is continued until one player wins ten times. He or she then wins the match. The computer signals the match winner by blinking the player's three LEDs ten times. At the end of the match, control is returned to the SYM-1 monitor.

A TYPICAL GAME

The right arrow lights up. The following LED pattern appears at the bottom: 10, 13, 14, 15. The player on the right (player 1) pushes key

"C," and the bottom row of LEDs goes blank, as the answer is incorrect. Because player 1 did not guess correctly and he or she still has time left in this turn, a new number is offered to player 1. LEDs 10, 13, 14, and 15 light up and the player pushes key "7." He or she wins and now the left arrow lights up, indicating that it is player 2's turn. This time the number proposed is 10, 12, 15. The left player pushes key "9." At this point, LEDs 10, 11, and 12 light up, indicating that the player is the winner for this turn as he/she has used less total time to make a correct guess than player 1.

Let us try again. The right arrow lights up; the number to translate appears in LEDs 10, 13, 14, and 15. Player 1 pushes key "7," and a left arrow appears. The next number lights LEDs 10 and 14. Player 2 pushes key "2." Again, the left-most three LEDs light up at the bottom, as player 2 was faster than player 1 at providing the correct answer.

THE ALGORITHM

The flowchart corresponding to the program is shown in Figure 3.4. A first waiting loop is implemented to measure the time that it takes for player 1 to guess correctly. Once player 1 has achieved a correct guess, his or her total time is accumulated in a variable called TEMP. It is then player 2's turn, and a similar waiting loop is implemented. Once both players have submitted their guesses, their respective guessing times are compared. The player with the least amount of time wins, and control flows either to the left or to the right, as shown by labels 1 and 2 on the flowchart in Figure 3.4. A secondary variable called PLYR1 or PLYR2 is used to count the number of games won by a specific player. This variable is incremented for the player who has won and tested against the value 10. If the value 10 has not been reached, a new game is started. If the value 10 has been reached, the player with this score is declared the winner of the match.

THE PROGRAM

The corresponding program uses only one significant data structure. It is called NUMTAB and is used to facilitate the display of the random binary numbers on the LEDs. Remember that LED #10 must always be lit (it is the "proceed" LED). LED #11 must always be off. LEDs 12, 13, 14, and 15 are used to display the binary number. Remember also that bit position 6 of Port 1B is not used. As a result, displaying a "0" will be accomplished by outputting the pattern

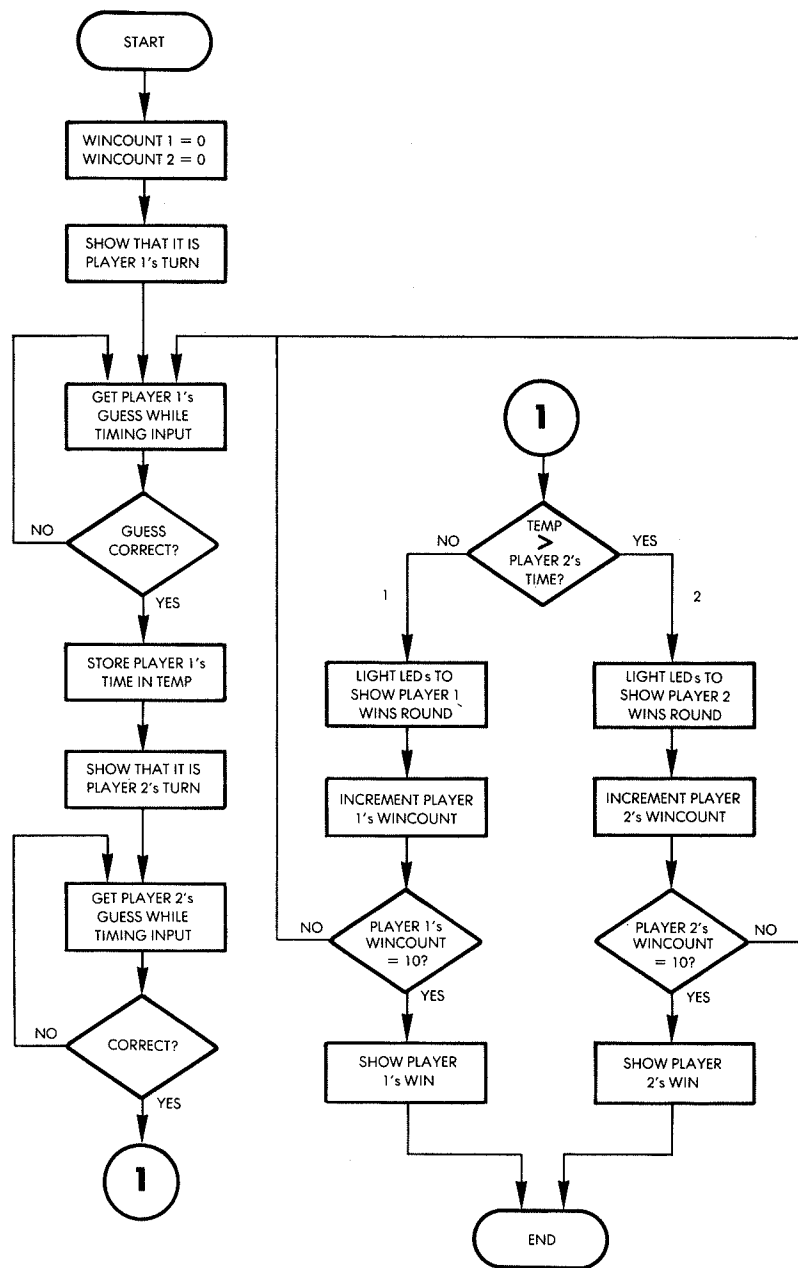
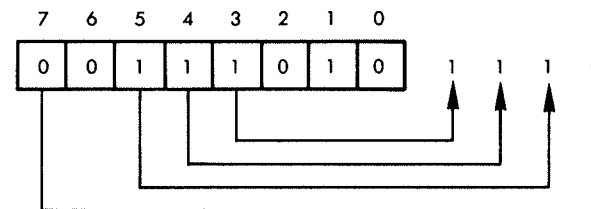

Fig. 3.4: Translate Flowchart

“00000010.” Outputting a “1” will be accomplished with the pattern “10000010.” Outputting “2” will be accomplished with the pattern “00100010.” Outputting “3” will be accomplished with the pattern “10100010,” etc. (See Figure 3.5)

The complete patterns corresponding to all sixteen possibilities are stored in the NUMTAB table of the program. (See Figure 3.6.) Let us examine, for example, entry 14 in the NUMTAB (see line 0060 of the program). It is “00111010.” The corresponding binary number to be displayed is, therefore: “00111.”



It is “1110” or 14. Remember that bit 6 on this port is always “0.”

Low Memory Area

Memory locations 0 to 1D are used to store the temporary variables and the NUMTAB table. The functions of the variables are:

| | |
|-------------------|--|
| TEMP | Storage for random delay-length |
| CNTHI,CNTLO | Time used by a player to make his or her move |
| CNT1H,CNT1L | Time used by player 1 to make his or her move (permanent storage) |
| PLYR1 | Score for Player 1(number of games won so far, up to a maximum of ten) |
| PLYR2 | Same for player 2 |
| NUMBER | Random number to be guessed |
| SCR and following | Scratch area used by the random number generator |

In the assembler listing, the method used to reserve memory locations in this program is different from the method used in the program in Chapter 2. In the MUSIC program, memory was reserved for the variables by simply declaring the value of the symbols representing the

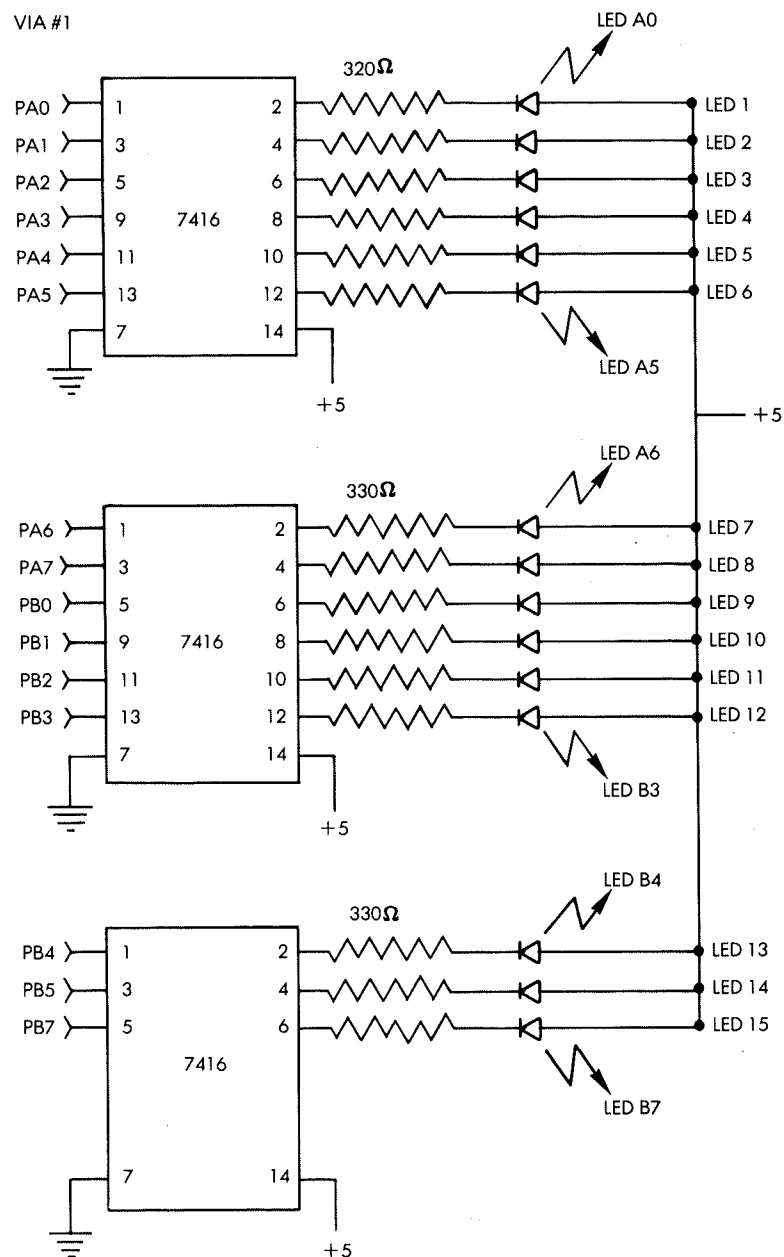

Fig. 3.5: LED Connections

variable locations with the statement:

$$\langle \text{VARIABLE NAME} \rangle = \langle \text{MEMORY ADDRESS} \rangle$$

In this program, the location counter of the assembler is incremented with expressions of the form:

$$* = * + n$$

Thus, the symbols for the variable locations in this program are declared as "labels," while, in the MUSIC program, they are "symbols" or "constant symbols."

The program in this chapter consists of one main routine, called MOVE, and five subroutines: PLAY, COUNTER, BLINK, DELAY, RANDOM. Let us examine them. The data direction registers A and B for the VIA's #1 and #3 of the board must first be initialized. DDR1A, DDR1B, and DDR3B are configured as outputs:

```
START      LDA #$FF
           STA DDR1A
           STA DDR1B
           STA DDR3B
```

DDR3A is conditioned as input:

```
LDA #0
STA DDR3A
```

Finally, the variables PLYR1 and PLYR2, used to accumulate the number of wins by each player, are initialized to zero:

```
STA PLYR1
STA PLYR2
```

The main body of MOVE is then entered. A right arrow will be displayed to indicate that it is player 2's turn. A reminder of the LEDs connections is shown in Figure 3.5. In order to display a right arrow, LEDs 1, 4, 5, 6, and 7 must be lit (refer also to Figure 3.1). This is accomplished by outputting the appropriate code to Port 1A:

```
MOVE      LDA #%01111001
           STA PORT1A      Display right arrow
```

The bottom line of LEDs must be cleared:

```
LDA #0
STA PORT1B
```

Finally, the counters measuring elapsed time must be cleared:

```
STA CNTLO
STA CNTHI
```

We are ready to play:

```
JSR PLAY
```

The PLAY routine will be described below. It returns to the calling routine with a time-elapsed measurement in locations CNTLO and CNTHI.

Let us return to the main program (line 0082 in Figure 3.6). The time-elapsed duration which has been accumulated at locations CNTLO and CNTHI by the PLAY routine is saved in a set of permanent locations reserved for player 1, called CNT1L, CNT1H:

```
LDA CNTLO
STA CNT1L
LDA CNTHI
STA CNT1H
```

It is then player 2's turn, and a left arrow is displayed. This is accomplished by turning on LEDs 3, 4, 5, and 6:

```
LDA #%000111100 Display left arrow
STA PORT1A
```

Then LED #9 is turned on to complete the left arrow:

```
LDA #1
STA PORT1B
```

As before, the time-elapsed counter is reset to zero:

```
LDA #0
STA CNTLO
STA CNTHI
```

```

LINE # LOC CODE LINE
0002 0000 ;'TRANSLATE'
0003 0000 ;PROGRAM TO TEST 2 PLAYER'S SPEED
0004 0000 ;IN TRANSLATING A BINARY NUMBER TO A SINGLE
0005 0000 ;HEXADECEMAL DIGIT, EACH PLAYER IS GIVEN A
0006 0000 ;TURN, AS SHOWN BY A LIGHTED LEFT OR RIGHT
0007 0000 ;POINTER, THE NUMBER WILL SUDDENLY FLASH ON
0008 0000 ;LEDS 12-15, ACCOMPANIED BY THE LIGHTING
0009 0000 ;OF LED #10. THE PLAYER MUST THEN
0010 0000 ;PUSH THE CORRESPONDING BUTTON. AFTER
0011 0000 ;BOTH PLAYERS TAKE TURNS, RESULTS ARE
0012 0000 ;SHOWN ON BOTTOM ROW. AFTER 10 WINS,
0013 0000 ;A PLAYER'S RESULTS WILL FLASH,
0014 0000 ;SHOWING THE BETTER PLAYER, THEN
0015 0000 ;THE GAME RESTARTS.
0016 0000 ;
0017 0000 ;I/O:
0018 0000 ;
0019 0000 PORT1A = $A001 ;LEDS 1-8
0020 0000 PORT1B = $A000 ;LEDS 9-15
0021 0000 DDR1A = $A003
0022 0000 DDR1B = $A002
0023 0000 PORT3A = $AC01 ;KEY STROBE INPUT.
0024 0000 PORT3B = $AC00 ;KEY # OUTPUT.
0025 0000 DDR3A = $AC03
0026 0000 DDR3B = $AC02
0027 0000 ;
0028 0000 ;VARIABLE STORAGE:
0029 0000 ;
0030 0000 * = $0
0031 0000 ;
0032 0000 TEMP **=*1
0033 0001 CNTHI **=*1 ;TEMPORARY STORAGE FOR AMT. OF
0034 0002 ;TIME PLYR USES TO GUESS.
0035 0002 CNTLO **=*1
0036 0003 CNTHI **=*1 ;AMT. OF TIME PLYR1 USES TO GUESS.
0037 0004 CNT1L **=*1
0038 0005 PLYR1 **=*1 ;SCORE OF # WON FOR PLYR1.
0039 0006 PLYR2 **=*1 ;PLAYER 2 SCORE.
0040 0007 NUMBER **=*1 ;STORES NUMBER TO BE GUESSED.
0041 0008 SCR **=*16 ;SCRATCHPAD FOR RND. # GEN.
0042 000E ;
0043 000E ;TABLE OF 'REVERSED' NUMBERS FOR DISPLAY
0044 000E ;IN BITS 3-8 OF PORT1B, OR LEDS 12-15.
0045 000E ;
0046 000E 02 NUNTAB .BYTE $00000010
0047 000F 82 .BYTE $10000010
0048 0010 22 .BYTE $00100010
0049 0011 A2 .BYTE $10100010
0050 0012 12 .BYTE $00010010
0051 0013 92 .BYTE $10010010
0052 0014 32 .BYTE $00110010
0053 0015 B2 .BYTE $10110010
0054 0016 0A .BYTE $00001010
0055 0017 8A .BYTE $10001010
0056 0018 2A .BYTE $00101010
0057 0019 AA .BYTE $10101010
0058 001A 1A .BYTE $00011010
0059 001B 9A .BYTE $10011010
0060 001C 3A .BYTE $00111010
0061 001D BA .BYTE $10111010
0062 001E ;
0063 001E ;MAIN PROGRAM
0064 001E ;
0065 001E * = $200
0066 0200 ;
0067 0200 A9 FF START LDA #$FF ;SET UP PORTS
0068 0202 8D 03 A0 STA DDR1A
0069 0205 8D 02 A0 STA DDR1B
0070 0208 8D 02 AC STA DDR3B
0071 020B A9 00 LDA #0
0072 020D 8D 03 AC STA DDR3A
0073 0210 85 05 STA PLYR1 ;CLEAR NO. OF WINS.
0074 0212 85 06 STA PLYR2
0075 0214 A9 79 MOVE LDA $20111001
0076 0216 8D 01 A0 STA PORT1A ;SHOW RIGHT ARROW.
0077 0219 A9 00 LDA #0
0078 021B 8D 00 A0 STA PORT1B
0079 021E 85 02 STA CNTLO ;CLEAR COUNTERS.
0080 0220 85 01 STA CNTHI
0081 0222 20 8C 02 JSR PLAY ;GET PLAYER 1'S TIME.
0082 0225 A5 02 LDA CNTLO ;XFER TEMP COUNT TO PERMANENT STORAGE.
0083 0227 85 04 STA CNT1L
0084 0229 A5 01 LDA CNTHI

```

Fig. 3.6: Translate Program

```

0085 022E 85 03      STA CNT1H
0086 022D A9 3C      LDA #Z000111100 ;SHOW LEFT ARROW.
0087 022F 8D 01 A0   STA PORT1A
0088 0232 A9 01      LDA #1
0089 0234 8D 00 A0   STA PORT1B
0090 0237 A9 00      LDA #0
0091 0239 85 02      STA CNTLO      ;CLEAR COUNTERS.
0092 023E 85 01      STA CNTHI
0093 023D 20 8C 02   JSR PLAY        ;GET PLAYER 2'S TIME.
0094 0240 A5 01      LDA CNTHI      ;GET PLAYER 2'S COUNT AND...
0095 0242 C5 03      CMP CNT1H     ;COMPARE TO PLAYER 1'S.
0096 0244 F0 04      BEQ EQUAL     ;CHECK LOW ORDER BYTES TO RESOLVE WINNER.
0097 0246 90 27      BCC PLR2     ;PLAYER 2 HAS SMALLER COUNT, SHOW IT.
0098 0248 80 08      BCS PLR1     ;PLAYER 1 HAS SMALLER COUNT, SHOW IT.
0099 024A A5 02      EQUAL LDA CNTLO ;HI BYTES WERE EQUAL, SO
0100 024C              CMP CNT1L     ;CHECK LOW BYTES.
0101 024E C5 04      BCC PLR2     ;COMPARE SCORES.
0102 024E 90 1F      BCC PLR2     ;PLAYER 2 WINS, SHOW IT.
0103 0250 80 00      BCS PLR1     ;PLAYER 1 WINS, SHOW IT.
0104 0252 A9 F0      PLR1 LDA #Z11110000 ;LIGHT RIGHT SIDE OF BOTTOM ROW
0105 0254 8D 00 A0   STA PORT1B
0106 0257 A9 00      LDA #0
0107 0259 8D 01 A0   STA PORT1A
0108 025C A9 40      LDA #*40
0109 025E 20 E3 02   JSR DELAY     ;WAIT A WHILE TO SHOW WIN.
0110 0261 E6 05      INC PLYR1    ;PLAYER 1 WINS ONE MORE...
0111 0263 A9 0A      LDA #10
0112 0265 C5 05      CMP PLYR1
0113 0267 D0 AB      BNE MOVE     ;IF NOT, PLAY ANOTHER ROUND.
0114 0269 A9 F0      LDA #Z11110000 ;YES - GET BLINK PATTERN.
0115 026B 20 CB 02   JSR BLINK    ;BLINK WINNING SIDE.
0116 026E 60          RTS          ;ENDGAME: RETURN TO MONITOR.
0117 026F A9 0E      PLR2 LDA #Z1110      ;LIGHT LEFT SIDE OF BOTTOM.
0118 0271 8D 00 A0   STA PORT1B
0119 0274 A9 00      LDA #0
0120 0276 8D 01 A0   STA PORT1A
0121 0279 A9 40      LDA #*40
0122 027B 20 E3 02   JSR DELAY     ;WAIT A WHILE TO SHOW WIN.
0123 027E E6 06      INC PLYR2    ;PLAYER 2 HAS WON ANOTHER ROUND...
0124 0280 A9 0A      LDA #10
0125 0282 C5 06      CMP PLYR2
0126 0284 D0 BE      BNE MOVE     ;IF NOT, PLAY ANOTHER ROUND.
0127 0286 A9 0E      LDA #Z1110    ;YES-GET PATTERN TO BLINK LEDS.
0128 0288 20 CB 02   JSR BLINK    ;BLINK THEM
0129 028B 60          RTS          ;END.
0130 028C              ;
0131 028C              ;SUBROUTINE 'PLAY'
0132 028C              ;GETS TIME COUNT OF EACH PLAYER, AND IF
0133 028C              ;BAD GUESSES ARE MADE, THE PLAYER IS
0134 028C              ;GIVEN ANOTHER CHANCE, THE NEW TIME ADDED TO
0135 028C              ;THE OLD.
0136 028C              ;
0137 028C 20 F4 02   PLAY JSR RANDOM ;GET RANDOM NUMBER.
0138 028F 20 E3 02   JSR DELAY    ;RANDOM - LENGTH DELAY.
0139 0292 20 F4 02   JSR RANDOM    ;GET ANOTHER.
0140 0295 29 0F      AND #*0F     ;KEEP UNDER 16 FOR USE AS
0141 0297 85 07      STA NUMBER   ;NUMBER TO GUESS.
0142 0299 AA          TAX          ;USE AS INDEX TO...
0143 029A B5 0E      LDA NUMTAB,X ;.GET REVERSED PATTERN FROM TABLE ...
0144 029C 0D 00 A0   ORA PORT1B  ;...TO DISPLAY IN LEDS 12-15.
0145 029F 8D 00 A0   STA PORT1B
0146 02A2 20 B5 02   JSR CNTSUB  ;GET KEYSTROKE & DURATION COUNT.
0147 02A5 C4 07      CPY NUMBER   ;IS KEYSTROKE CORRECT GUESS?
0148 02A7 F0 0B      BEQ DONE    ;IF SO, DONE.
0149 02A9 A9 01      LDA #*01    ;NO: CLEAR OLD GUESS FROM LEDS.
0150 02AB 2D 00 A0   AND PORT1B
0151 02AE 8D 00 A0   STA PORT1B
0152 02B1 4C 8C 02   JMP PLAY    ;TRY AGAIN W/ANOTHER NUMBER.
0153 02B4 60          RTS          ;RETURN W/ DURATION IN CNTLO+CNTHI
0154 02B5              ;
0155 02B5              ;SUBROUTINE 'COUNTER'
0156 02B5              ;GETS KEYSTROKE WHILE KEEPING TRACK OF AMT OF
0157 02B5              ;TIME BEFORE KEYPRESS.
0158 02B5              ;
0159 02B5 A0 0F      CNTSUB LDY #*F ;SET UP KEY# COUNTER.
0160 02B7 8C 00 AC   KEYLP STY PORT3B ;OUTPUT KEY# TO KEYBOARD MPXR.
0161 02BA 2C 01 AC   BIT PORT3A  ;KEY DOWN?
0162 02BD 10 0B      BPL FINISH  ;IF YES, DONE.
0163 02BF 88          DEY          ;COUNT DOWN KEY #.
0164 02C0 10 F5      BPL KEYLP   ;TRY NEXT KEY.
0165 02C2 E6 02      INC CNTLO   ;ALL KEYS TRIED, INCREMENT COUNT.

```

Fig. 3.6: Translate Program (Continued)

```

0166 02C4 D0 EF              BNE CNTSUB ;TRY KEYS AGAIN IF NO OVERFLOW.
0167 02C6 E6 01              INC CNTHI ;OVERFLOW, INCREMENT HIGH BYTE.
0168 02C8 D0 EB              BNE CNTSUB ;TRY KEYS AGAIN.
0169 02CA 60                  FINISH RTS ;DONE: TIME RAN OUT OR KEY PRESSED.
0170 02CB                      ;
0171 02CB                      ;SUBROUTINE 'BLINK'
0172 02CB                      ;BLINKS LEDS WHOSE BITS ARE SET IN ACCUMULATOR
0173 02CB                      ;ON ENTRY.
0174 02CB                      ;
0175 02CB A2 14              BLINK LDX #20 ;20 BLINKS.
0176 02CD 86 01              STX CNTHI ;SET BLINK COUNTER.
0177 02CF 85 02              STA CNTLO ;BLINK REGISTER.
0178 02D1 A5 02              BLOOP LDA CNTLO ;GET BLINK PATTERN.
0179 02D3 AD 00 A0           EOR PORT1B ;BLINK LEDS.
0180 02D6 8D 00 A0           STA PORT1B
0181 02D9 A9 0A              LDA #10 ;SHORT DELAY.
0182 02DB 20 E3 02           JSR DELAY
0183 02DE C6 01              DEC CNTHI
0184 02E0 D0 EF              BNE BLOOP   ;LOOP IF NOT DONE.
0185 02E2 60                  RTS
0186 02E3                      ;
0187 02E3                      ;SUBROUTINE 'DELAY'
0188 02E3                      ;CONTENTS OF REG. A DETERMINES DELAY LENGTH.
0189 02E3                      ;
0190 02E3 85 00              DELAY STA TEMP
0191 02E5 A0 10              DL1 LDY #10
0192 02E7 A2 FF              DL2 LDX #*FF
0193 02E9 CA              DL3 DEX
0194 02EA D0 FD              BNE DL3
0195 02EC 88                  DEY
0196 02ED D0 FB              BNE DL2
0197 02EF C6 00              DEC TEMP
0198 02F1 D0 F2              BNE DL1
0199 02F3 60                  RTS
0200 02F4                      ;
0201 02F4                      ;SUBROUTINE 'RANDOM'
0202 02F4                      ;RANDOM NUMBER GENERATOR.
0203 02F4                      ;RETURNS RANDOM NUMBER IN ACCUM.
0204 02F4                      ;
0205 02F4 38                  RANDOM SEC
0206 02F5 A5 09              LDA SCR+1
0207 02F7 65 0C              ADC SCR+4
0208 02F9 65 0D              ADC SCR+5
0209 02FB 85 08              STA SCR
0210 02FD A2 04              LDX #4
0211 02FF B5 08              RNDLP LDA SCR,X
0212 0301 95 09              STA SCR+1,X
0213 0303 CA              DEX
0214 0304 10 F9              BPL RNDLP
0215 0306 60                  RTS
0216 0307                      .END

```

SYMBOL TABLE

SYMBOL VALUE

| | | | | | | | |
|--------|------|--------|------|--------|------|--------|------|
| BLINK | 02CB | BLOOP | 02D1 | CNT1H | 0003 | CNT1L | 0004 |
| CNTHI | 0001 | CNTLO | 0002 | CNTSUB | 02B5 | DDR1A | A003 |
| DDR1B | A002 | DDR3A | AC03 | DDR3B | AC02 | DELAY | 02E3 |
| DL1 | 02E5 | DL2 | 02E7 | DL3 | 02E9 | DONE | 02B4 |
| EQUAL | 024A | FINISH | 02CA | KEYLP | 02B7 | MOVE | 0214 |
| NUMBER | 0007 | NUMTAB | 000E | PLAY | 028C | PLR1 | 0252 |
| PLR2 | 024F | PLYR1 | 0005 | PLYR2 | 0006 | PORT1A | A001 |
| PORT1B | A000 | PORT3A | AC01 | PORT3B | AC00 | RANDOM | 02F4 |
| RNDLP | 02FF | SCR | 0008 | START | 0200 | TEMP | 0000 |

END OF ASSEMBLY

Fig. 3.6: Translate Program (Continued)

and player 2 can play:

JSR PLAY

The time elapsed for player 2 is then compared to the time elapsed for player 1. If player 2 wins, a branch occurs to PLR2. If player 1 wins, a branch occurs to PLR1. The high bytes are compared first. If they are equal, the low bytes are compared in turn:

| | | |
|-------|-----------|--------------------------|
| | LDA CNTHI | |
| | CMP CNT1H | Compare high bytes |
| | BEQ EQUAL | |
| | BCC PLR2 | Player 2 has lower time? |
| | BCS PLR1 | Player 1 does |
| EQUAL | LDA CNTLO | Compare low bytes |
| | CMP CNT1L | |
| | BCC PLR2 | |
| | CMP CNT1L | |
| | BCC PLR2 | |
| | BCS PLR1 | |

Once the winner has been identified, the bottom row of LEDs on his or her side will light up, pointing to the winner. Let us follow what happens when PLR1 wins, for example. Player 1's right-most three LEDs (LEDs 13 through 15) are lit up:

```
PLR1    LDA #%11110000
        STA PORT1B
```

The other LEDs on the Games Board are cleared:

```
LDA #0
STA PORT1A
```

A DELAY is then implemented, and we get ready to play another game, up to a total of 10:

```
LDA #$40
JSR DELAY
```

The score for player 1 is incremented:

```
INC PLYR1
```

It is compared to 10. If it is less than 10, a return occurs to the main MOVE routine:

```
LDA #10
CMP PLYR1
BNE MOVE
```

Otherwise, the maximum score of 10 has been reached and the game is over. The LEDs on the winner's side will blink:

```
LDA #%11110000  Blink pattern
JSR BLINK
RTS
```

The corresponding sequence for player 2 is listed at address PLR2 (line 117 on Figure 3.6):

```
PLR2    LDA #%1110
        STA PORT1B
        LDA #0
        STA PORT1A
        LDA #$40
        JSR DELAY
        INC PLYR2
        LDA #10
        CMP PLYR2
        BNE MOVE
        LDA #%1110
        JSR BLINK
        RTS
```

The Subroutines

PLAY Subroutine

The PLAY subroutine will first wait for a random period of time before displaying the binary number. This is accomplished by calling the RANDOM subroutine to obtain the random number, then the DELAY subroutine to implement the delay:

```
PLAY    JSR RANDOM
        JSR DELAY
```

The RANDOM subroutine will be described below. Another random number is then obtained. It is trimmed down to a value between 0 and 15, inclusive. This will be the binary number displayed on the LEDs. It is stored at location NUMBER:

```

JSR RANDOM
AND #0F      Mask off high nibble
STA NUMBER

```

The NUMTAB table, described at the beginning of this section, is then accessed to obtain the correct pattern for lighting the LEDs using indexed addressing. Register X contains the number between 0 and 15 to be displayed:

```

TAX          Use X as index
LDA NUMTAB,X Retrieve pattern

```

The pattern in the accumulator is then stored in the output register in order to light the LEDs. Note that the pattern is OR'ed with the previous contents of the output register so that the status of LED 9 is not changed:

```

ORA PORT1B
STA PORT1B

```

Once the random number has been displayed in binary form on the LEDs, the subroutine waits until the player presses a key. The CNTSUB subroutine is used for this purpose:

```

JSR CNTSUB

```

It will be described below.

The value returned in register Y by this subroutine is compared to the number to be guessed, which is stored at memory address NUMBER. If the comparison succeeds, exit occurs. Otherwise, all LEDs are cleared using an AND, to prevent changing the status of LED 9, and the subroutine is reentered. Note that the remaining time for the player will be decremented every time the CNTSUB subroutine is called. It will eventually decrement to 0, and this player will be given another number to guess:

```

CPY NUMBER   Correct guess?
BEQ DONE
LDA #01      No: clear old guess
AND PORT1B
STA PORT1B
JMP PLAY     Try again
RTS

```

DONE

Exercise 3-1: Modify PLAY and/or CNTSUB so that, upon timeout, the player loses the current round, as if the maximum amount of time had been taken to make the guess.

CNTSUB Subroutine

The CNTSUB subroutine is used by the PLAY subroutine previously described. It monitors a player's keystroke and records the amount of time elapsed until the key is pressed. The key scanning is performed in the usual way:

```

CNTSUB      LDY #$F
KEYLP      STY PORT3B
           BIT PORT3A
           BPL FINISH
           DEY          Count down key #
           BPL KEYLP    Next key
FINISH      BNE CNTSUB

```

Each time that all keys have been scanned unsuccessfully, the time elapsed counter is incremented (CNTLO,CNTHI):

```

           INC CNTLO
           BNE CNTSUB
           INC CNTHI
           BNE CNTSUB
FINISH      RTS

```

Upon return of the subroutine, the number corresponding to the key which has been pressed is contained in index register Y.

Exercise 3-2: Insert some "do-nothing" instructions into the CNTSUB subroutine so that the guessing time is longer.

BLINK Subroutine

The LEDs specified by the accumulator contents are blinked (turned on and off) ten times by this subroutine. It uses memory location CNTHI and CNTLO as scratch registers, and destroys their previous contents. Since the LEDs must alternately be turned on and off, an exclusive-OR instruction is used to provide the automatic on/off feature by performing a complementation. Because two complementations of the LED status must be done to blink the LEDs once, the loop is executed 20 times. Note also that LEDs must be kept lit for a minimum amount of time. If the "on" delay was too short, the LEDs would appear to be continuously lit. The program is shown below:

| | | |
|-------|------------|-------------------|
| BLINK | LDX #20 | 20 blinks |
| | STX CNTHI | Blink counter |
| | STA CNTLO | Blink register |
| BLOOP | LDA CNTLO | Get blink pattern |
| | EOR PORT1B | Blink LEDs |
| | STA PORT1B | |
| | LDA #10 | Short delay |
| | JSR DELAY | |
| | DEC CNTHI | |
| | BNE BLOOP | Loop if not done |
| | RTS | |

DELAY Subroutine

The DELAY subroutine implements a classic three-level, nested loop design. Register X is set to a maximum value of FF (hexadecimal), and used as the inner loop counter. Register Y is set to the value of 10 (hexadecimal) and used as the level-2 loop counter. Location TEMP contains the number used to adjust the delay and is the counter for the outermost loop. The subroutine design is straightforward:

| | |
|-------|-----------|
| DELAY | STA TEMP |
| DL1 | LDY #\$10 |
| DL2 | LDX #\$FF |
| DL3 | DEX |
| | BNE DL3 |
| | DEY |

```
BNE DL2
DEC TEMP
BNE DL1
RTS
```

Exercise 3-3: Compute the exact duration of the delay implemented by this subroutine as a function of the number contained in location TEMP.

RANDOM Subroutine

This simple random number generator returns a semi-random number into the accumulator. A set of six locations from memory address 0008 ("SCR") have been set aside as a scratch-pad for this generator. The random number is computed as 1 plus the contents of the number in location SCR + 1, plus the contents of the number in location SCR + 4, plus the contents of the number in location SCR + 5:

| | |
|--------|-------------|
| RANDOM | SEC |
| | LDA SCR + 1 |
| | ADC SCR + 4 |
| | ADC SCR + 5 |
| | STA SCR |

The contents of the scratch area (SCR and following locations) are then shifted down in anticipation of the next random number generation:

| | |
|-------|-------------|
| RNDLP | LDX #4 |
| | LDA SCR,X |
| | STA SCR+1,X |
| | DEX |
| | BPL RNDLP |
| | RTS |

The process is illustrated in Figure 3.7. Note that it implements a seven-location circular shift. The random number which has been computed is written back in location SCR, and all previous values at memory locations SCR and following are pushed down by one position. The previous contents of SCR + 5 are lost. This ensures that the numbers will be reasonably random.

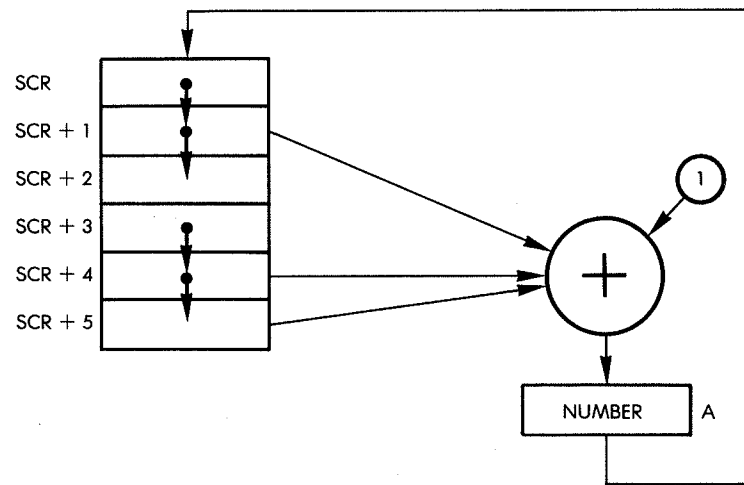

Fig. 3.7: Random Number Generation

SUMMARY

This game involved two players competing with each other. The time was kept with nested loops. The random number to be guessed was generated by a pseudo-random number generator. A special table was used to display the binary number. LEDs were used on the board to indicate each player's turn to display the binary number, and to indicate the winner.

Exercise 3-4: *What happens in the case in which all memory locations from SCR to SCR + 5 were initially zero?*

4

HEXGUESS

THE RULES

The object of this game is to guess a secret 2-digit number generated by the computer. This is done by guessing a number, then submitting this number to the computer and using the computer's response (indicating the proximity of the guessed number to the secret number) to narrow down a range of numbers in which the secret number resides. The program begins by generating a high-pitched beep which signals to the player that it is ready for a number to be typed. The player must then type in a two-digit hexadecimal number. The program responds by signaling a win if the player has guessed the right number. If the player has guessed incorrectly, the program responds by lighting up one to nine LEDs, indicating the distance between the player's guess and the correct number. One lit LED indicates that the number guessed is a great distance away from the secret number, and nine lit LEDs indicate that the number guessed is very close to the secret number.

If the guess was correct, the program generates a warbling tone and flashes the LEDs on the board. The player is allowed a maximum of ten guesses. If he or she fails to guess the correct number in ten tries, a low tone is heard and a new game is started.

A TYPICAL GAME

The computer beeps, notifying us that we should type in a guess.

Our guess is: "40"

The computer lights 4 LEDs

We are somewhat off

Next guess: "C0"
 Computer's answer: 3 LEDs We are going further away
 Next guess: "20"
 Computer's response: 3 The number must be between C0 and 20

 Next guess: "80"
 Response: 5 We are getting closer
 Next guess: "75"
 Response: 5 It's not just below 80
 Next guess: "90"
 Response: 4 We're wandering away
 Next guess: "65"
 Response: 7 Now we're closing in
 Next guess: "60"
 Response: 9
 Next guess: "5F"
 Response: 8
 Next guess: "61"
 We win!!! All the LEDs flash and a high warbling tone is heard.

THE ALGORITHM

The flowchart for Hexguess is shown in Figure 4.1. The algorithm is straightforward:

- a random number is generated
- a guess is entered
- the closeness of the number guessed to the secret number is evaluated. Nine levels of proximity are available and are displayed by an LED on the board. A closeness or proximity table is used for this purpose.
- a win or a loss is signaled
- more guesses are allowed, up to a maximum of ten.

THE PROGRAM

Data Structures

The program consists of one main routine called GETGES, and two subroutines called LITE and TONE. It uses one simple data structure

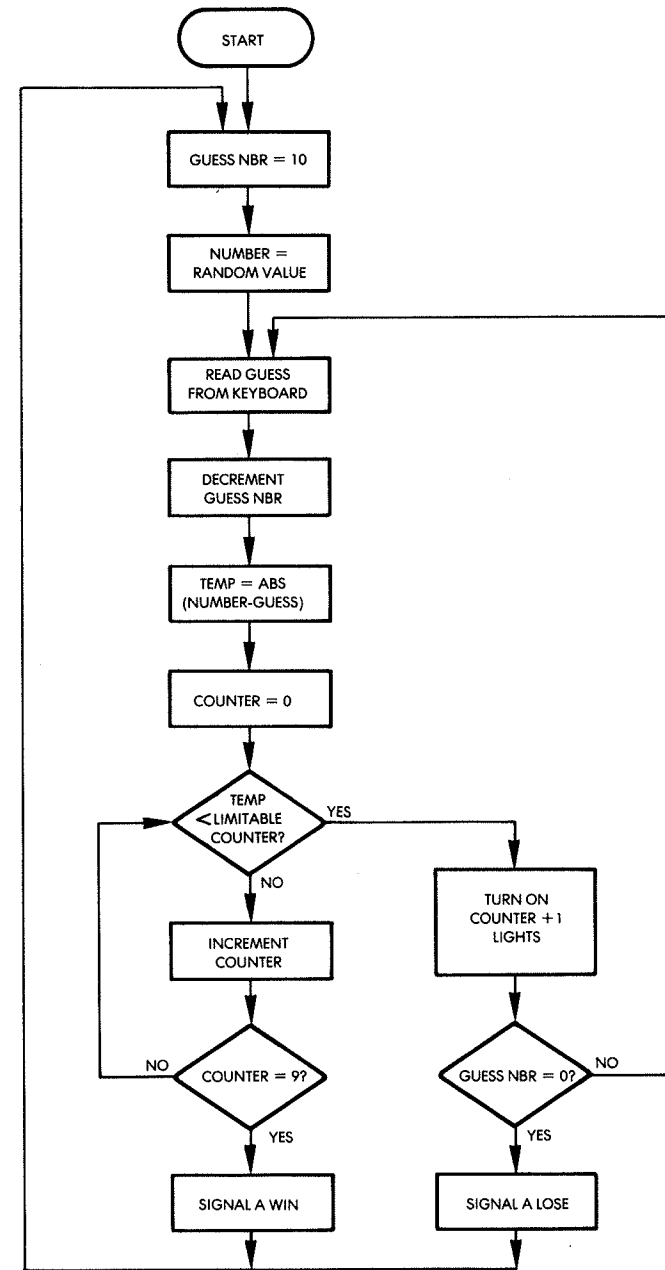

Fig. 4.1: Hexguess Flowchart

— a table called LIMITS. The flowchart is shown in Figure 4.1, and the program listing appears in Figure 4.2.

The LIMITS table contains a set of nine values against which the proximity of the guess to the computer's secret number will be tested. It is essentially exponential and contains the sequence: 1,2,4,8,16,32,64,128,200.

Program Implementation

Let us examine the program itself. It resides at memory address 200 and may not be relocated. Five variables reside in page zero:

GUESS is used to store the current guess
 GUESS# is the number of the current guess
 DUR and FREQ are the usual parameters required to generate a tone (TONE subroutine)
 NUMBER is the secret computer number

As usual, the data direction registers VIA #1 and VIA #3 are conditioned in order to drive the LED display and read the keyboard:

```
LDA #$FF
STA DDR1A    OUTPUT
STA DDR1B    OUTPUT
STA DDR3B    OUTPUT
```

Memory location DUR is used to store the duration of the tone to be generated by the TONE subroutine. It is initialized to "FF" (hex):

```
STA DUR
```

The memory location GUESS# is used to store the number of guesses. It is initialized to 10:

```
START    LDA #$0A
          STA GUESS#
```

The LEDs on the Games Board are turned off:

```
LDA #00
STA PORT1A
STA PORT1B
```

```
'HEXGUESS'
;HEXADECIMAL NUMBER GUESSING GAME.
;THE OBJECT OF THE GAME IS TO GUESS A HEXADECIMAL
;NUMBER THAT THE COMPUTER HAS THOUGHT UP.
;WHEN THE COMPUTER "BEEPS", A GUESS SHOULD
;BE ENTERED. GUESSES ARE TWO DIGIT HEXADECIMAL
;NUMBERS. WHEN TWO DIGITS HAVE BEEN RECEIVED,
;THE COMPUTER WILL DISPLAY THE NEARNESS
;OF THE GUESS BY LIGHTING A NUMBER OF
;LEDS PROPORTIONAL TO THE CLOSENESS OF
;THE GUESS. TEN GUESSES ARE ALLOWED.
;IF A GUESS IS CORRECT, THEN THE COMPUTER
;WILL FLASH THE LEDES AND MAKE A WARBLING
;TONE.
;THE ENTRY LOCATION IS $200.
;
GETKEY = $100
;6522 VIA #1 ADDRESSES:
TIMER = $A004 ;LOW LATCH OF TIMER 1
DDR1A = $A003 ;PORTA DATA DIRECTION REG.
DDR1B = $A002 ;PORTB DATA DIRECTION REG.
PORT1A = $A001 ;PORT A
PORT1B = $A000 ;PORT B
;6522 VIA #3 ADDRESSES:
DDR3B = $AC02 ;PORTB DATA DIRECTION REG.
PORT3B = $AC00 ;PORT B
;STORAGES:
GUESS = $00
GUESS# = $01
DUR = $02
FREQ = $03
NUMBER = $04
;
; = $200
0200: A9 FF          LDA #$FF          ;SET UP DATA DIRECTION REGISTERS
0202: 8D 03 A0      STA DDR1A
0205: 8D 02 A0      STA DDR1B
0208: 8D 02 AC      STA DDR3B
020B: 85 02          STA DUR          ;SET UP TONE DURATIONS.
020D: A9 0A          START LDA #$0A          ;10 GUESSES ALLOWED
020F: 85 01          STA GUESS#
0211: A9 00          LDA #00          ;BLANK LEDES
0213: 8D 01 A0      STA PORT1A
0216: 8D 00 A0      STA PORT1B
0219: AD 04 A0      LDA TIMER        ;GET RANDOM NUMBER TO GUESS
021C: 85 04          STA NUMBER      ;...AND SAVE.
021E: A9 20          GETGES LDA #$20   ;SET UP SHORT HIGH TONE TO
                                ;SIGNAL USER TO INPUT GUESS.
0220: 20 96 02          JSR TONE        ;MAKE BEEP.
0223: 20 00 01          JSR GETKEY     ;GET HIGH ORDER USER GUESS
0226: 0A              ASL A          ;SHIFT INTO HIGH ORDER POSITION
0227: 0A              ASL A
0228: 0A              ASL A
0229: 0A              ASL A
022A: 85 00          STA GUESS      ;SAVE
022C: 20 00 01          JSR GETKEY     ;GET LOW ORDER USER GUESS
022F: 29 0F          AND #$200001111 ;MASK HIGH ORDER BITS.
0231: 05 00          ORA GUESS     ;ADD HIGH ORDER NIBBLE.
0233: 85 00          STA GUESS     ;FINAL PRODUCT SAVED.
0235: A5 04          LDA NUMBER    ;GET NUMBER FOR COMPARE
0237: 38              SEC
0238: E5 00          SBC GUESS     ;SUBTRACT GUESS FROM NUMBER
                                ;TO DETERMINE NEARNESS OF GUESS.
023A: B0 05          BCS ALRIGHT   ;POSITIVE VALUE NEEDS NO FIX.
023C: 49 FF          EOR $21111111 ;MAKE DISTANCE ABSOLUTE
023E: 38              SEC
023F: 69 00          ADC #00       ;...NOT JUST A ONES COMPLEMENT.
```

Fig. 4.2: Hexguess Program

```

0241: A2 00 ALRIGHT LDX #00 ;SET CLOSENESS COUNTER TO DISTANT
0243: DD AD 02 LOOP CMP LIMITS,X ;COMPARE NEARNESS OF GUESS TO
;TABLE OF LIMITS TO SEE HOW MANY
;LIGHTS TO LIGHT.

0246: B0 27 BCS SIGNAL ;NEARNESS IS BIGGER THAN LIMIT, SO
;GO LIGHT INDICATOR.

0248: EB INX ;LOOK AT NEXT CLOSENESS LEVEL.
0249: E0 09 CPX #9 ;ALL NINE LEVELS TRIED?
024B: D0 F6 BNE LOOP ;NO, TRY NEXT LEVEL.
024D: A9 0B WIN LDA #11 ;YES: WIN! LOAD NUMBER OF BLINKS
024F: 85 00 STA GUESS ;USE GUESS AS TEMP
0251: A9 FF LDA #$FF ;LIGHT LEDS
0253: 8D 01 A0 STA PORT1A
0254: 8D 00 A0 STA PORT1B
0259: A9 32 WOW LDA #50 ;TONE VALUE
025B: 20 96 02 JSR TONE ;MAKE WIN SIGNAL
025E: A9 FF LDA #$FF
0260: 4D 01 A0 EOR PORT1A ;COMPLEMENT PORTS
0263: 8D 01 A0 STA PORT1A
0264: 8D 00 A0 STA PORT1B
0269: C6 00 DEC GUESS ;BLINKS/TONES DONE?
026B: D0 EC BNE WOW ;NO, DO AGAIN
026D: F0 9E BEQ START ;YES, START NEW GAME.
026F: EB SIGNAL INX ;INCREMENT CLOSENESS-LEVEL
;COUNTER SO AT LEAST 1 LED IS LIT.
;CLEAR HIGH LED PORT

0270: A9 00 LDA #0
0272: 8D 00 A0 STA PORT1B
0275: 20 8E 02 JSR LITE ;GET LED PATTERN
027B: 8D 01 A0 STA PORT1A ;SET LEDS
027E: 90 05 BCC CC ;IF CARRY SET PBO = 1
027D: A9 01 LDA #01
027F: 8D 00 A0 STA PORT1B
0282: C6 01 CC DEC GUESS# ;ONE GUESS USED
0284: D0 9B BNE GETGES ;SOME LEFT, GET NEXT.
0286: A9 BE LDA #$BE ;LOW TONE SIGNALS LOSE
0288: 20 96 02 JSR TONE
028B: 4C 0D 02 JMP START ;NEW GAME.

;
;ROUTINE TO MAKE PATTERN OF LIT LEDS BY SHIFTING A
;STRING OF ONES TO THE LEFT IN THE ACCUMULATOR UNTIL
;THE BIT POSITION CORRESPONDING TO THE NUMBER IN X
;IS REACHED.
;
028F: A9 00 LITE LDA #0 ;CLEAR ACCUMULATOR FOR PATTERN
0290: 3B SHIFT SEC ;MAKE LOW BIT HIGH.
0291: 2A ROL A ;SHIFT IT IN
0292: CA DEX ;ONE BIT DONE...
0293: D0 FB BNE SHIFT ;LOOP IF NOT DONE.
0295: 60 RTS ;RETURN

;
;TONE GENERATION ROUTINE.
;
0296: 85 03 TONE STA FREQ
0298: A9 00 LDA #$00
029A: A6 02 LDX DUR
029C: A4 03 FL2 LDY FREQ
029E: 88 FL1 DEY
029F: 18 CLC
02A0: 90 00 BCC ,+2
02A2: D0 FA BNE FL1
02A4: A9 FF EOR #$FF
02A6: 8D 00 AC STA PORT3B
02A9: CA DEX
02AA: D0 F0 BNE FL2
02AC: 60 RTS

;
;TABLE OF LIMITS FOR CLOSENESS LEVELS.
;

```

Fig. 4.2: Hexguess Program (Continued)

```

02AD: C8 LIMITS .BYTE 200,128,64,32,16,8,4,2,1
02AE: 80
02AF: 40
02B0: 20
02B1: 10
02B2: 08
02B3: 04
02B4: 02
02B5: 01

SYMBOL TABLE:
GETKEY 0100 TIMER A004 DDR1A A003
DDR1B A002 PORT1A A001 PORT1B A000
DDR3B AC02 PORT3B AC00 GUESS 0000
GUESS# 0001 DUR 0002 FREQ 0003
NUMBER 0004 START 0200 GETGES 021E
ALRIGHT 0241 LOOP 0243 WIN 024D
WOW 0259 SIGNAL 026F CC 0282
LITE 028E SHIFT 0290 TONE 0296
FL2 029C FL1 029E LIMITS 02AD

```

Fig. 4.2: Hexguess Program (Continued)

The program will generate a random number which must be guessed by the player. A reasonably random number is obtained here by reading the value of timer1 of VIA #1. It is then stored in memory address NUMBER:

```

LDA TIMER      Low latch of timer 1
STA NUMBER

```

A random number generator is not required because requests for random numbers occur at random time intervals, unlike the situation in most of the other games that will be described. An important observation on the use of T1CL of a 6522 VIA is that it is often called a "latch" but it is a "counter" when performing a read operation! Its contents are *not* frozen during a read as they would be with a latch. They are continuously decremented. When they decrement to 0, the counter is reloaded from the "real" latch.

Note that in Figure 4.3 T1L-L is shown twice — at addresses 04 and 06. This is a possible source of confusion and should be clearly understood. Location 4 corresponds to the counter; location 6 corresponds to the latch. Location 4 is read here.

We are ready to go. A high-pitched tone is generated to signal the player that a guess may be entered. The note duration is stored at

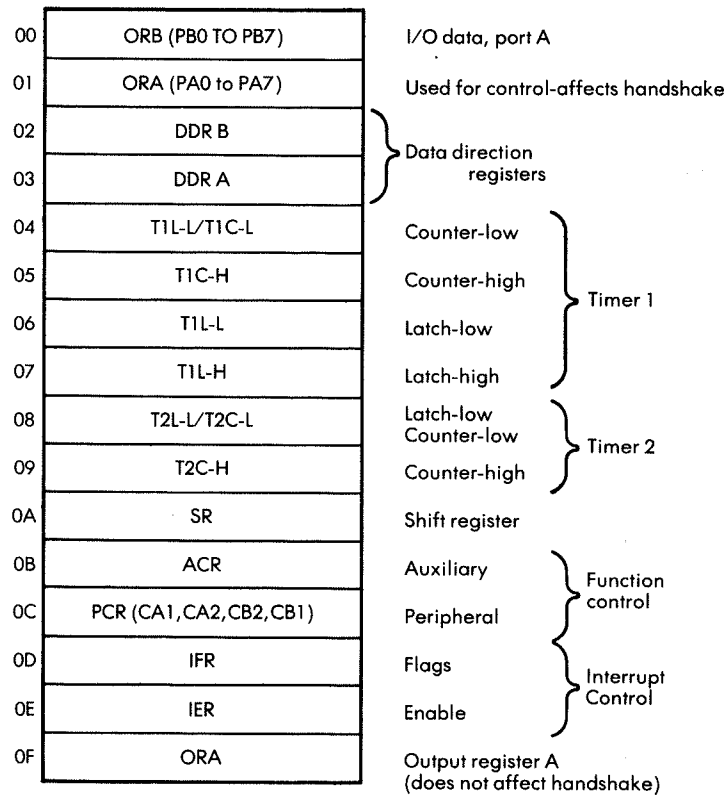

Fig. 4.3: 6522 VIA Memory Map

memory location DUR while the note frequency is set by the contents of the accumulator:

```
GETGES    LDA #$20      High pitch
          JSR TONE
```

Two key strokes must be accumulated for each guess. The GETKEY subroutine is used to obtain the number of the key being pressed, which is then stored in the accumulator. Once the first character has been obtained, it is shifted left by four positions into the high nibble position, and the next character is obtained. (See Figure 4.4.)

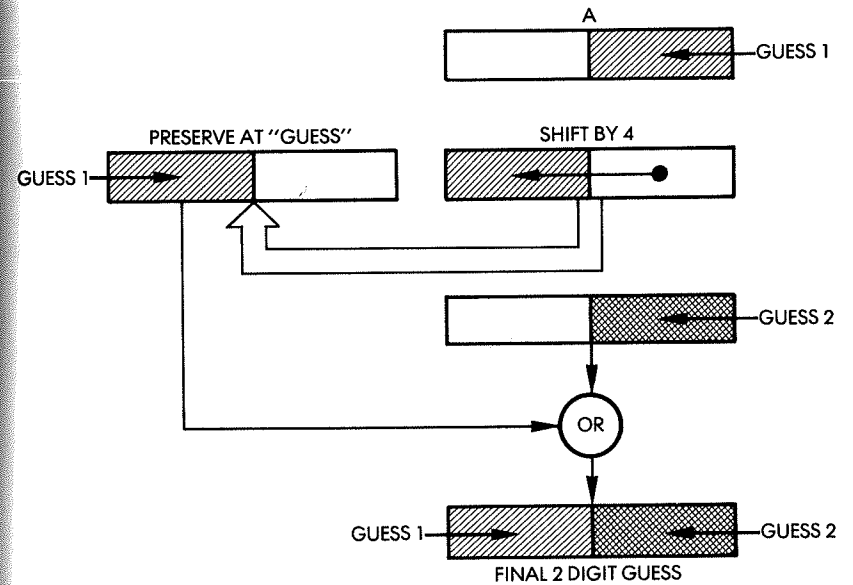

Fig. 4.4: Collecting the Player's Guess

```
JSR GETKEY
ASL A
ASL A
ASL A
ASL A
STA GUESS
JSR GETKEY
```

Once the second character has been transferred into the accumulator, the previous character, which had been saved in memory location GUESS, is retrieved and OR'ed back into the accumulator:

```
AND #%00001111
ORA GUESS
```

It is stored back at memory location GUESS:

```
STA GUESS
```

Now that the guess has been obtained, it must be compared against the random number stored by the computer at memory location NUMBER. A subtraction is performed:

```
LDA NUMBER
SEC
SBC GUESS
```

Note that if the difference is negative, it must be complemented:

```
BCS ALRIGHT      Positive?
EOR #%01111111  It is negative: complement
SEC              Make it two's complement
ADC #00         Add one
```

Once the "distance" from the guess to the actual number has been computed, the "closeness-counter" must be set to a value between 1 and 9 (only nine LEDs are used). This is done by a loop which compares the absolute "distance" of the guess from the correct number to a bracket value in the LIMITS table. The number of the appropriate bracket value becomes the value assigned to the proximity or closeness of the guessed number to the secret number. Index register X is initially set to 0, and the indexed addressing mode is used to retrieve bracket values. Comparisons are performed as long as the "distance" is less than the bracket value, or until X exceeds 9, i.e., until the highest table value is looked up.

```
ALRIGHT  LDX #00
LOOP     CMP LIMITS,X   Look up limit value
        BCS SIGNAL
        INX            Closeness is less
        CPX #9        Keep trying 10 times
        BNE LOOP
```

At this point, unless a branch has occurred to SIGNAL, the distance between the guess and the actual number is 0: it is a win. This is signaled by blinking the LEDs and by generating a special win tone:

```
WIN      LDA #11
        STA GUESS      Scratch storage
        LDA #FF
```

```
STA PORT1A
STA PORT1B
WOW      LDA #50      Tone pitch
        JSR TONE     Generate tone
```

The blinking is generated by complementing the LEDs repeatedly:

```
LDA #$FF
EOR PORT1A      Complement ports
STA PORT1A
STA PORT1B
```

The loop is executed again:

```
DEC GUESS
BNE WOW
```

Finally, when the loop index (GUESS) reaches zero, a branch occurs back to the beginning of the main program: START:

```
BEQ START
```

If, however, the current guess is not correct, a branch to SIGNAL occurs during bracket comparison, with the contents of the X register being the proximity value: i.e., the number of LEDs to light. Depending on the closeness of the guess to the secret number, LEDs #1 to #9 will be turned on:

```
SIGNAL  INX            Increment closeness level
        LDA #0        Clear high LED port
        STA PORT1B
        JSR LITE      Get LED pattern
        STA PORT1A
        BCC CC        If carry set, PB0 = 1
        LDA #01
        STA PORT1B
```

The number of LEDs to turn on is in X. It must be converted into the appropriate pattern to put on the output port. This is done by the LITE subroutine, described below.

If LED #9 is to be turned on, the carry bit is set by LITE. An ex-

PLICIT test of the carry for this case is done above (the pattern 01 is then sent to PORT1B). The number of the current guess is decremented next. If it is 0, the player has lost: the lose signal is generated and a

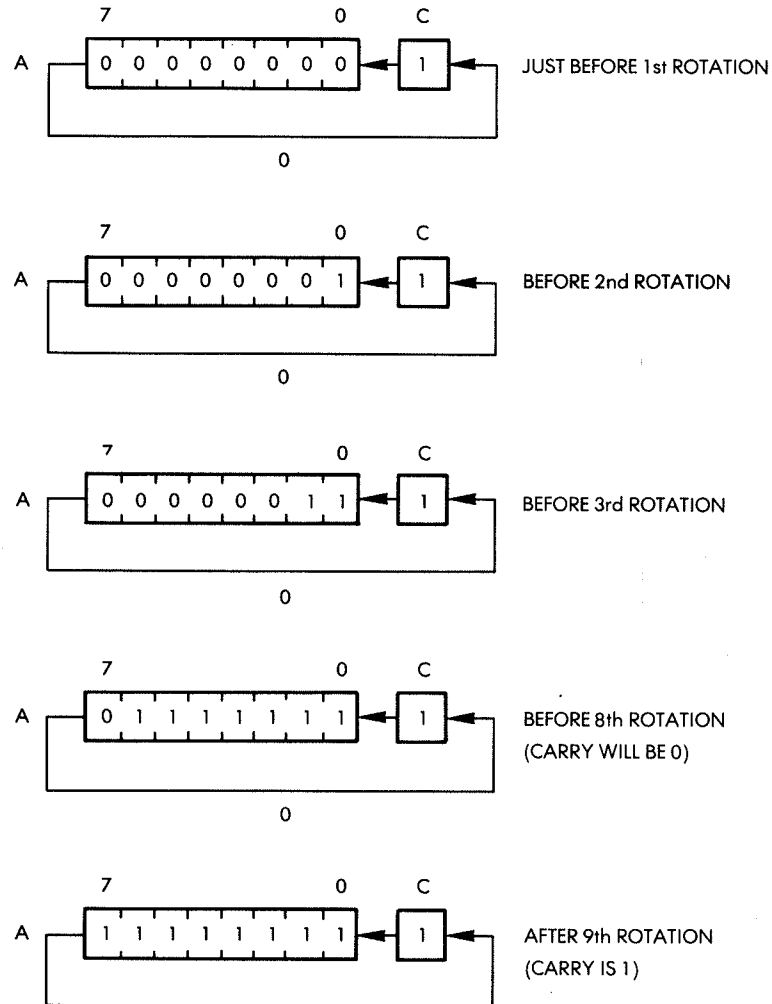

Fig. 4.5: Obtaining the LED pattern for 8 LED's

new game is started; otherwise, the next guess is obtained:

```

CC          DEC GUESS#
            BNE GETGES      Any guesses left?
            LDA #$BE        Low tone
            JSR TONE
            JMP START       New game
  
```

The Subroutines

LITE Subroutine

The LITE subroutine will generate the pattern required to light up LEDs #1 to #8, depending on the number contained in register X. The required "1" bits are merely shifted right in the accumulator as register X is being decremented. An example is given in Figure 4.5.

Upon exit from the subroutine, the accumulator contains the correct pattern required to light up the specified LEDs. If LED #9 is included, the pattern would consist of all ones, and the carry bit would be set:

```

LITE        LDA #0
SHIFT      SEC          Starting "1"
           ROL A       Rotate the "1" to position
           DEX          Done?
           BNE SHIFT
           RTS
  
```

TONE Subroutine

The TONE subroutine will generate a tone for a duration specified by a constant in memory location DUR, at the frequency specified by the contents of the accumulator. Index register Y is used as the inner loop counter. The tone is generated, as usual, by turning the speaker connected to PORT3B on and off successively during the appropriate period of time:

```

TONE        STA FREQ
           LDA #$00
           LDX DUR
           LDY FREQ
           DEY
  
```

```

CLC
BCC .+ 2
BNE FL1
EOR #$FF
STA PORT3B
DEX
BNE
RTS

```

SUMMARY

This time, the program used the timer's latch (i.e., a hardware register) rather than a software routine as a random number generator. A simple "LITE" routine was used to display a value, and the usual TONE routine was used to generate a sound.

EXERCISES

Exercise 4-1: *Improve the Hexguess program by adding the following feature to it. At the end of each game, if the player has lost, the program will display [the number which the player should have guessed] for approximately 3 seconds, before starting a new game.*

Exercise 4-2: *What would happen if the SEC at location 290 hexadecimal were left out?*

Exercise 4-3: *What are the advantages and disadvantages of using the timer's value to generate a random number? What about the successive numbers? Will they be related? Identical?*

Exercise 4-4: *How many times does the above program blink the lights when it signals a win?*

Exercise 4-5: *Examine the WIN routine (line 24D). Will the win tone be sounded once or several times?*

Exercise 4-6: *What is the purpose of the two instructions at addresses 29F and 2A0? (Hint: read Chapter 2.)*

Exercise 4-7: *Should the program start the timer?*

Exercise 4-8: *Is the number of LEDs lit in response to a guess linearly related to the closeness of a guess?*

5

MAGIC SQUARE

THE RULES

The object of the game is to light up a perfect square on the board, i.e., to light LEDs 1, 2, 3, 6, 9, 8, 7, and 4 but not LED #5 in the center.

The game is started with a random pattern. The player may modify the LED pattern on the board through the use of the keyboard, since each of the keys complements a group of LEDs. For example, each of the keys corresponding to the corner LED positions (key numbers: 1, 3, 9, and 7) complements the pattern of the square to which it is attached. Key #1 will complement the pattern formed by LEDs 1, 2, 4, 5. Assuming that LEDs 1, 2, and 4 are lit, pressing key #1 will result in the following pattern: 1-off, 2-off, 4-off, 5-on.

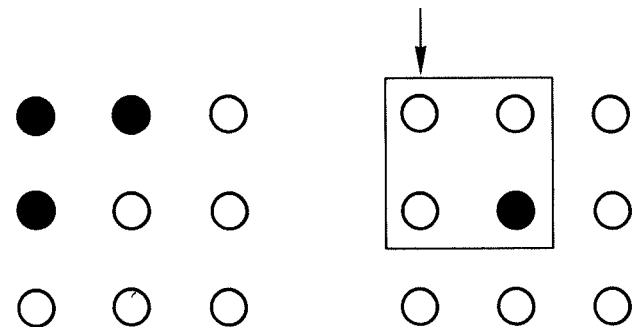

The pattern formed by LEDs 1, 2, 4, and 5 has been complemented and only LED #5 is lit after pressing key #1. Pressing key #1 again will result in: 1, 2, and 4-on with 5-off. Pressing a key twice results in two

successive complementations, i.e., it cancels out the first action.
 Similarly, key #9 complements the lower right-hand square formed by LEDs 5, 6, 8, and 9.
 Key #3 complements the pattern formed by LEDs 2, 3, 5, and 6.
 Key #7 complements the pattern formed by LEDs 4, 5, 7, and 8.
 The "edge keys" corresponding to LEDs 2, 4, 6, and 8 complement the pattern formed by the three LEDs of the outer edge of which they are a part. For example, pressing key #2 will complement the pattern for LEDs 1, 2, and 3. Assume an initial pattern with LEDs 1, 2, and 3 lit. Pressing key #2 will result in obtaining the complemented pattern, i.e., turning off all three LEDs. Similarly, assume an initial pattern on the left vertical edge where LEDs 4 and 7 are lit.

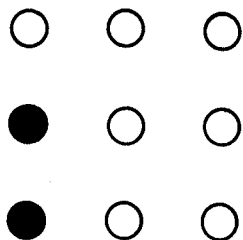

Pressing key #4 will result in a pattern where LED #1 is lit and LEDs 4 and 7 are turned off.

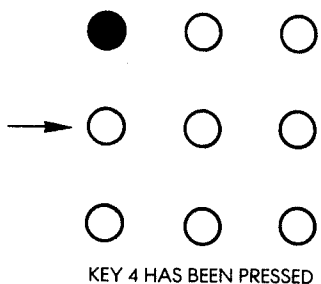

Likewise, key #8 will complement the pattern formed by LEDs 7, 8, and 9, and key #6 will complement the pattern formed by LEDs 3, 6, and 9.

Finally, pressing key #5 (the center LED position) will result in complementing the pattern formed by LEDs 2, 4, 5, 6, and 8. For example, assume the following initial pattern where only LEDs 6 and 8 are lit:

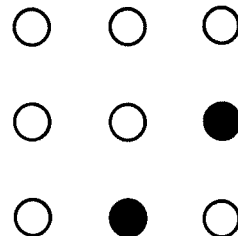

Pressing key #5 will result in lighting up LEDs 2, 4, and 5:

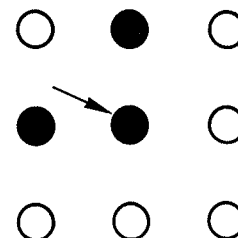

The winning combination in which all LEDs on the edge of the square are lit is obtained by pressing the appropriate sequence of keys.

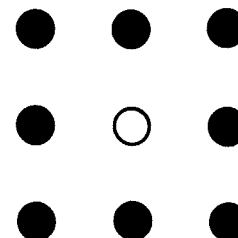

The mathematical proof that it is always possible to achieve a "win" is left as an exercise for the reader. The program confirms that the player has achieved the winning pattern by flashing the LEDs on and off.

Key "0" must be used to start a new game. A new random pattern of lit LEDs will be displayed on the board. The other keys are ignored.

A TYPICAL GAME

Here is a typical sequence:

The initial pattern is: 1-3-4-6-9.

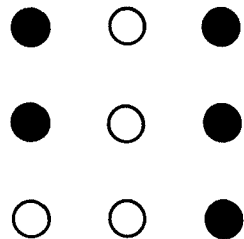

Move: press key #8.

The resulting pattern is: 1-3-4-6-7-8.

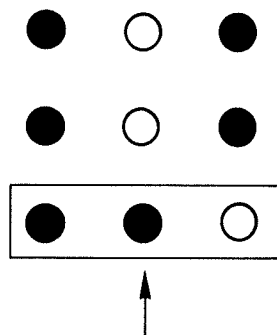

Next move: press key #2.

The resulting pattern is: 2-4-6-7-8.

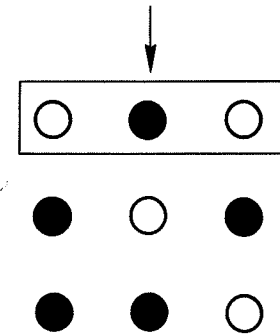

Next move: press key #3.

The resulting pattern is: 3-4-5-7-8.

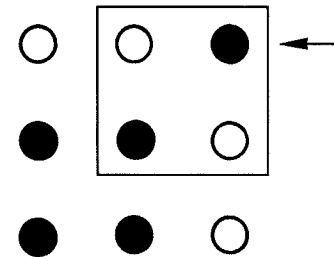

Next move: press key #2.

The resulting pattern is 1-2-4-5-7-8.

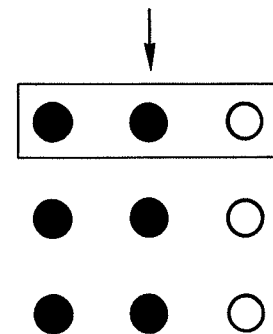

Next move: press key #6.
 The resulting pattern is 1-2-3-4-5-6-7-8-9.

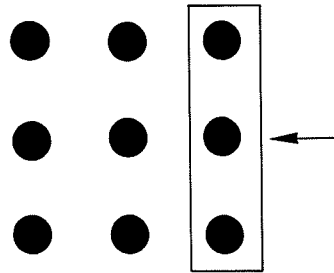

Note that this is a “classic” pattern in which all LEDs on the board are lit. It is not a winning situation, as LED #5 should be off. Let us proceed.

Next move: the end of this game is left to the mathematical talent of the reader. The main purpose was to demonstrate the effect of the various moves.

Hint: a possible winning sequence is 2-4-6-8-5!

General advice: in order to win this game, try to arrive quickly at a symmetrical pattern on the board. Once a symmetrical pattern is obtained, it becomes a reasonably simple matter to obtain the perfect square. Generally speaking, a symmetrical pattern is obtained by hitting the keys corresponding to the LEDs which are off on the board but which should be “on” to complete the pattern.

THE ALGORITHM

A pattern is generated on the board using random numbers. The key corresponding to the player’s move is then identified, and the appropriate group of LEDs on the board is complemented.

A table must be used to specify the LEDs forming a group for each key.

The new pattern is tested against a perfect square. If one exists, the player wins. Otherwise, the process begins anew.

The detailed flowchart is shown in Figure 5.1.

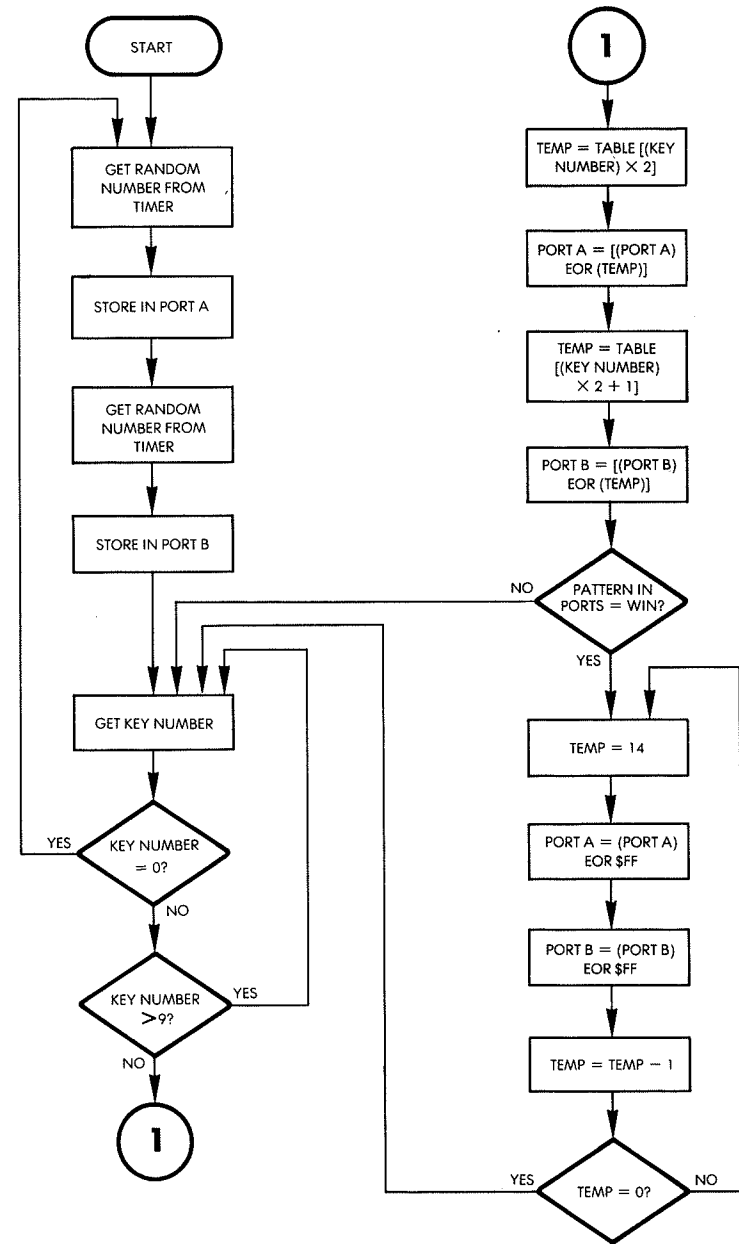

Fig. 5.1: Magic Square Flowchart

THE PROGRAM

Data Structures

The main problem here is to devise an efficient way to complement the correct LED pattern whenever a key is pressed. The complementation itself may be performed by an Exclusive-OR instruction. In this case, the pattern used with the EOR instruction should contain a "1" in each LED position which is to be complemented, and "0" elsewhere. The solution is quite simple: a nine-entry table, called TABLE, is used. Each table entry corresponds to a key and has 16 bits of which only nine are used inasmuch as only nine LEDs are used. Each of the nine bits contains a "1" in the appropriate position, indicating the LED which will be affected by the key.

For example, we have seen that key number 1 will result in complementing LEDs 1, 2, 4, and 5. The corresponding table entry is therefore: 0, 0, 0, 1, 1, 0, 1, 1, where bits 1, 2, 4, and 5 (starting the numbering at 1, as with the keys) have been set to "1." Or, more precisely, using a 16-bit pattern:

0, 0, 0, 0, 0, 0, 0, 0, 0, 0, 0, 1, 1, 0, 1, 1

The complete table appears below in Figure 5.2.

| KEY | PATTERN | |
|-----|----------|----------|
| 1 | 00011011 | 00000000 |
| 2 | 00000111 | 00000000 |
| 3 | 00110110 | 00000000 |
| 4 | 01001001 | 00000000 |
| 5 | 10111010 | 00000000 |
| 6 | 00100100 | 00000001 |
| 7 | 11011000 | 00000000 |
| 8 | 11000000 | 00000001 |
| 9 | 10110000 | 00000001 |

Fig. 5.2: Complementation Table

Program Implementation

A random pattern of LEDs must be lit on the board at the beginning of the game. This is done, as in the previous chapter, by reading the value of the VIA #1 timer. If a timer were not available, a random number-generating routine could be substituted.

```

; 'MAGIC SQUARE' PROGRAM
;KEYS 1-9 ON THE HEX KEYBOARD ARE EACH ASSOCIATED
;WITH ONE LED IN THE 3X3 ARRAY. WHEN A KEY IS PRESSED,
;IT CHANGES THE PATTERN OF THE LIT LEDES IN THE ARRAY.
;THE OBJECT OF THE GAME IS TO CONVERT THE RANDOM
;PATTERN THE GAME STARTS WITH TO A SQUARE OF LIT
;LEDS BY PRESSING THE KEYS. THE LEDES WILL FLASH WHEN
;THE WINNING PATTERN IS ACHIEVED.
;KEY #0 CAN BE USED AT ANY TIME TO RESTART
;THE GAME WITH A NEW PATTERN.
;
GETKEY  =#$100
T1CL    =#$A004          ;LOW REGISTER OF TIMER IN 6522 VIA
PORT1   =#$A001          ;6522 VIA PORT A
PORT2   =#$A000          ;6522 VIA PORT B
TEMP    =#$0000          ;TEMPORARY STORAGE
DDRA    =#$A003          ;DATA DIRECTION REGISTER OF PORT A
DDRB    =#$A002          ;SAME FOR PORT B
        =#$200
;
;COMMENTS: THIS PROGRAM USES A TIMER REGISTER FOR A
; RANDOM NUMBER SOURCE. IF NONE IS AVAILABLE, A
; RANDOM NUMBER GENERATOR COULD BE USED, BUT
; DUE TO ITS REPEATABILITY, IT WOULD NOT WORK AS
; WELL. THIS PROGRAM USES PORT A'S REGISTERS FOR
; STORAGE OF THE LED PATTERN. SINCE WHAT IS READ
; BY THE PROCESSOR IS THE POLARITY OF THE
; OUTPUT LINES, AN EXCESSIVE LOAD ON THE LINES WOULD
; PREVENT THE PROGRAM FROM WORKING CORRECTLY.
;
0200: A9 FF          LDA #$FF          ;SET UP PORTS FOR OUTPUT
0202: 8D 03 A0       STA DDRA
0205: 8D 02 A0       STA DDRB
0208: AD 04 A0       START LDA T1CL          ;GET 1ST RANDOM NUMBER
020B: 8D 01 A0       STA PORT1
020E: AD 04 A0       LDA T1CL          ;...AND SECOND.
0211: 29 01         AND #01
0213: 8D 00 A0       STA PORT2
0216: 20 00 01      KEY JSR GETKEY
0219: C9 00         CMP #0
021B: F0 EB         BEQ START        ;YES, RESTART GAME WITH NEW BOARD.
021D: C9 0A         CMP #10
021F: 10 F5         BFL KEY          ;+ IF KEY >=10, SO GET ANOTHER
;
;FOLLOWING SECTION USES KEY NUMBER AS INDEX TO FIND IN
;TABLE A BIT PATTERN USED TO COMPLEMENT LED'S
;
0221: 38           SEC          ;DECREMENT A FOR TABLE ACCESS
0222: E9 01       SBC #1
0224: 0A         ASL A          ;MULTIPLY AX2, SINCE EACH ENTRY IN
;TABLE IS TWO BYTES.
0225: AA         TAX          ;USE A AS INDEX
0226: AD 01 A0   LDA PORT1       ;GET PORT CONTENTS FOR COMPLEMENT
0229: 5D 68 02   EOR TABLE,X    ;EOR PORT CONTENTS W/PATTERN
022C: 8D 01 A0   STA PORT1       ;RESTORE PORT1
022F: AD 00 A0   LDA PORT2       ;DO SAME WITH PORT2.
0232: 5D 6C 02   EOR TABLE+1,X ;...USING NEXT TABLE ENTRY.
0235: 29 01     AND #01
0237: 8D 00 A0   STA PORT2       ;...AND RESTORE.
;
;THIS SECTION CHECKS FOR WINNING PATTERN IN LEDES
;
023A: 4A         LSR A          ;SHIFT BIT 0 OF PORT 1 INTO CARRY.
023B: 90 D9     BCC KEY        ;IF NOT WIN PATTERN, GET NEXT MOVE.
023D: AD 01 A0   LDA PORT1       ;LOAD PORT1 FOR WIN TEST
0240: C9 EF     CMP #11101111 ;CHECK FOR WIN PATTERN
0242: D0 D2     BNE KEY        ;NO WIN, GET NEXT MOVE

```

Fig. 5.3: Magic Square Program

```

;
;WIN BLINK LED'S EVERY 1/2 SEC, 4 TIMES
;
0244: A9 0E          LDA #14
0246: 85 00          STA TEMP          ;LOAD NUMBER OF BLINKS
0248: A2 20          BLINK LDX ##20      ;DELAY CONSTANT FOR .08 SEC
024A: A0 FF          DELAY LDY ##FF      ;OUTER LOOP OF VARIABLE DELAY
                                ;ROUTINE, WHOSE DELAY TIME
                                ;IS 2556 * (CONTENTS OF X ON ENTER
                                ;10 MICROSEC LOOP U

024C: EA           DLY     NOP
024D: B0 00          BNE .+2
024F: 88           DEY
0250: D0 FA          BNE DLY
0252: CA           DEX
0253: D0 F5          BNE DELAY
0255: AD 01 A0       LDA PORT1        ;GET PORTS AND COMPLEMENT THEM
0258: 49 FF          EOR ##FF
025A: 8D 01 A0       STA PORT1
025D: AD 00 A0       LDA PORT2
0260: 49 01          EOR #1
0262: 8D 00 A0       STA PORT2
0265: C6 00          DEC TEMP        ;COUNT DOWN NUMBER OF BLINKS
0267: B0 DF          BNE BLINK      ;DO AGAIN IF NOT DONE
0269: F0 AB          BEQ KEY        ;GET NEXT MOVE

;
;TABLE OF CODES USED TO COMPLEMENT LEDS
;
026B: 1B           TABLE .BYT Z00011011,Z00000000
026C: 00
026D: 07           .BYT Z00000111,Z00000000
026E: 00
026F: 36           .BYT Z00110110,Z00000000
0270: 00
0271: 49           .BYT Z01001001,Z00000000
0272: 00
0273: BA           .BYT Z10111010,Z00000000
0274: 00
0275: 24           .BYT Z00100100,Z00000001
0276: 01
0277: DB           .BYT Z11011000,Z00000000
0278: 00
0279: C0           .BYT Z11000000,Z00000001
027A: 01
027B: B0           .BYT Z10110000,Z00000001
027C: 01

SYMBOL TABLE:
GETKEY      0100      T1CL      A004      PORT1     A001
PORT2       A000      TEMP      0000      DDRA      A003
DDRB        A002      START    0208      KEY       0216
BLINK       0248      DELAY    024A      DLY       024C
TABLE       026B

%

```

Fig. 5.3: Magic Square Program (Continued)

The data direction registers for Ports A and B of the VIA are configured for output to drive the LEDs:

```

LDA #$FF
STA DDRA
STA DDRB

```

The "random" numbers are then obtained by reading the value of timer 1 of the VIA and are used to provide a random pattern for the LEDs. (Two numbers provide 16 bits, of which 9 are kept.)

```

START      LDA T1CL      Get 1st number
           STA PORT1    Use it
           LDA T1CL      Get 2nd number
           AND #01      Keep only position 0
           STA PORT2    Use it

```

An explanation of the use of T1CL has been presented in the previous chapter. The program then monitors the keyboard for the key stroke of the player. It will accept only inputs "0" through "9" and will reject all others:

```

KEY        JSR GETKEY
           CMP #0        Is key 0?
           BEQ START
           CMP #10
           BPL KEY       If key = 10 get another

```

If the player has pressed key "0," the program is restarted with a new LED display. If it is a value between "1" and "9" that is pressed, the appropriate change must be performed on the LED pattern. The key number will be used as an index to the table of complementation codes. Since the keys are labeled 1 through 9, the key number must first be decremented by 1 in order to be used as an index. Since the table contains double-byte entries, the index number must also be multiplied by 2. This is performed by the following three instructions:

```

SEC
SBC #1     Subtract 1
ASL A      Multiply by 2

```

Remember that a shift left is equivalent to a multiplication by 2 in the binary system. The resulting value is used as an index and stored in index register X:

TAX

The LED pattern is stored in the Port A data registers. It will be complemented by executing an EOR instruction on Port 1, then repeating the process for Port 2:

```
LDA PORT1
EOR TABLE,X      Complement Port1
STA PORT1
LDA PORT2         Same for Port2
EOR TABLE + 1,X
AND #01          Mask out unused bits
STA PORT2
```

Note that assembly-time arithmetic is used to specify the second byte in the table:

EOR TABLE + 1,X

Once the pattern has been complemented, the program checks for a winning pattern. To do so, the contents of Port 2 and Port 1 must be matched against the correct LED pattern. For Port 2, this is "0, 0, 0, 0, 0, 0, 1." For Port 1, this is "1, 1, 1, 0, 1, 1, 1." Bit 0 of Port 2 happens presently to be contained in the accumulator and can be tested immediately after a right shift:

```
LSR A           Shift bit 0 of Port 2
BCC KEY
```

The contents of Port 1 must be explicitly compared to the appropriate pattern:

```
LDA PORT1
CMP #%11101111
BNE KEY
```

To confirm the win, LEDs are now blinked on the board. TEMP is used as a counter variable; X is used to set the fixed delay duration. Y is used as a counter for the innermost loop. Each port is complemented after the delay has elapsed.

```
BLINK          LDA #14
DELAY          STA TEMP          Load number of blinks
              LDX #$20          Delay constant for .08 sec
              LDY #$FF          Outer loop of variable
                                  delay routine, whose delay
                                  time is 2556 × (Contents
                                  of X on entry) 10 μs loop

DLY           NOP
              BNE . + 2
              DEY
              BNE DLY
              DEX
              BNE DELAY
              LDA PORT1        Get ports and complement
                                  them
              EOR #$FF
              STA PORT1
              LDA PORT2
              EOR #1
              STA PORT2
              DEC TEMP          Count down number of blinks
              BNE BLINK        Do again if not done
              BEQ KEY          Get next key
```

SUMMARY

This game of skill required a special table to perform the various complementations. The timer is used directly to provide a pseudo-random number, rather than a program. The LED pattern is stored directly in the I/O chip's registers.

EXERCISES

Exercise 5-1: Rewrite the end of the program using a delay subroutine.

Exercise 5-2: Will the starting pattern be reasonably random?

Exercise 5-3: *Provide sound effects.*

Exercise 5-4: *Allow the use of key "A" to perform a different change such as a total complementation.*

Exercise 5-5 (more difficult): *Write a program which allows the computer to play and win.*

Exercise 5-6: *Add to the previous exercise the following feature: record the number of moves played by the computer, then play against the computer. You must win in fewer moves. You may specify an identical starting pattern for yourself and the computer. In this case, you should start, then let the computer "show you." If the computer requires more moves than you do, you are either an excellent player, a lucky player, or you are a poor programmer. Perhaps you are using the wrong algorithm!*

6

SPINNER

THE RULES

A light spins around the square formed by LEDs 1, 2, 3, 6, 9, 8, 7, and 4, in a counterclockwise fashion.

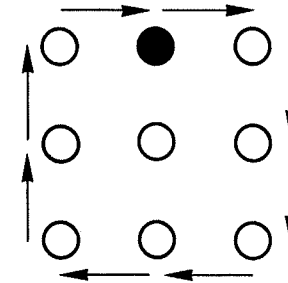

The object of the game is to stop the light by hitting the key corresponding to the LED at the exact time that the LED lights up. Every time that the spinning light is stopped successfully, it will start spinning at a faster rate. Every time that the player fails to stop the LED within 32 spins, the light will stop briefly on LED #4, then resume spinning at a slower pace. The expert player will be able to make the light spin faster and faster, until the maximum speed is reached. At this point, all the LEDs on the Games Board (LEDs 1 through 15) light up simultaneously. It is a win, and a new game is started.

Each win is indicated to the player by a hesitation of the light on the LED corresponding to the key pressed. When a complete game is won, all LEDs on the Games Board will be lit.

This game can also be used to sharpen a player's reflexes, or to test his or her reaction time. In some cases, a player's reaction may be too slow to catch the rotating LED even at its slowest speed. In such a case, the player may be authorized to press two, or even three, consecutive keys at once. This extends the player's response time. For example, with this program, if the player would press keys 7, 8, and 9 simultaneously, the light would stop if it was at any one of those positions (7, 8, or 9).

THE ALGORITHM

The flowchart is presented in Figure 6.1. The game may operate at eight levels of difficulty, corresponding to the successive speeds of the "blip" traveling with increased rapidity around the LED square. An 8-bit counter register is used for two functions simultaneously. (See Figure 6.2.) The lower 3 bits of this register are used as the "blip-counter" and point to the current position of the light on the LED square. Three bits will select one of eight LEDs. The left-most 5 bits of this register are used as a "loop-counter" to indicate how many times the blip traverses the loop. Five bits allow up to 32 repetitions. LEDs are lit in succession by incrementing this counter. Whenever the blip-counter goes from "8" to "0," a carry will propagate into the loop-counter, incrementing it automatically. Allocating the 8 bits of register Y to two different conceptual counters facilitates programming. Another convention could be used.

Every time that an LED is lit, the keyboard is scanned to determine whether the corresponding key has been pressed. Note that if the key was pressed prior to the LED being lit, it will be ignored. This is accomplished with an "invalid flag." Thus, the algorithm checks to see whether or not a key was initially depressed and then ignores any further closures if it was. A delay constant is obtained by multiplying the difficulty level by four. Then, during the delay while the LED is lit, a new check is performed for a key closure if no key had been pressed at the beginning of this routine. If a key had been pressed at the beginning it will be treated as a miss, and the program will not check again to see if the key was pressed as the "invalid flag" will have been set.

Every time the correct key is pressed during the delay while the LED is on (left branch of the flowchart in the middle section of Figure 6.1), the value of the difficulty level is decremented (a lower difficulty number results in a higher rotation speed). For every miss on the part

of the player, the difficulty value is incremented up to 15, resulting in a slower spin of the light. Once a difficulty level of 0 has been reached, if a hit is recorded, all LEDs on the board will light to acknowledge the situation.

THE PROGRAM

Data Structures

The program uses two tables. The KYTBL table stores the key numbers corresponding to the circular LED sequence: 1,2,3,6,9,8,7,4. It is located at memory addresses 0B through 12. See the program listing in Figure 6.3.

The second table, LTABLE, contains the required bit patterns which must be sent to the VIA's port to illuminate the LEDs in sequence. For example, to illuminate LED #1, bit pattern "00000001, or 01 hexadecimal, must be sent. For LED #2, the bit pattern "00000010" must be sent, or 02 hexadecimal. Similarly, for the other LEDs, the required pattern is: 04, 20, 00, 80, 40; 0B in hexadecimal.

Note that there is an exception for LED #9. The corresponding pattern is "0" for Port 1, and bit 0 of Port 2 must also be turned on. We will need to check for this special situation later on.

Program Implementation

Three variables are stored in memory page 0:

| | |
|--------|--|
| DURAT | Is the delay between two successive LED illuminations |
| DIFCLT | Is the "difficulty level" (reversed) |
| DNTST | Is a flag used to detect an illegal key closure when scanning the keys |

As usual, the program initializes the three required data direction registers: DDR1 on both Port A and Port B for the LEDs, and DDR3B for the keyboard:

```
START      LDA #$FF
           STA DDRIA
           STA DDRIB
           STA DDR3B
```

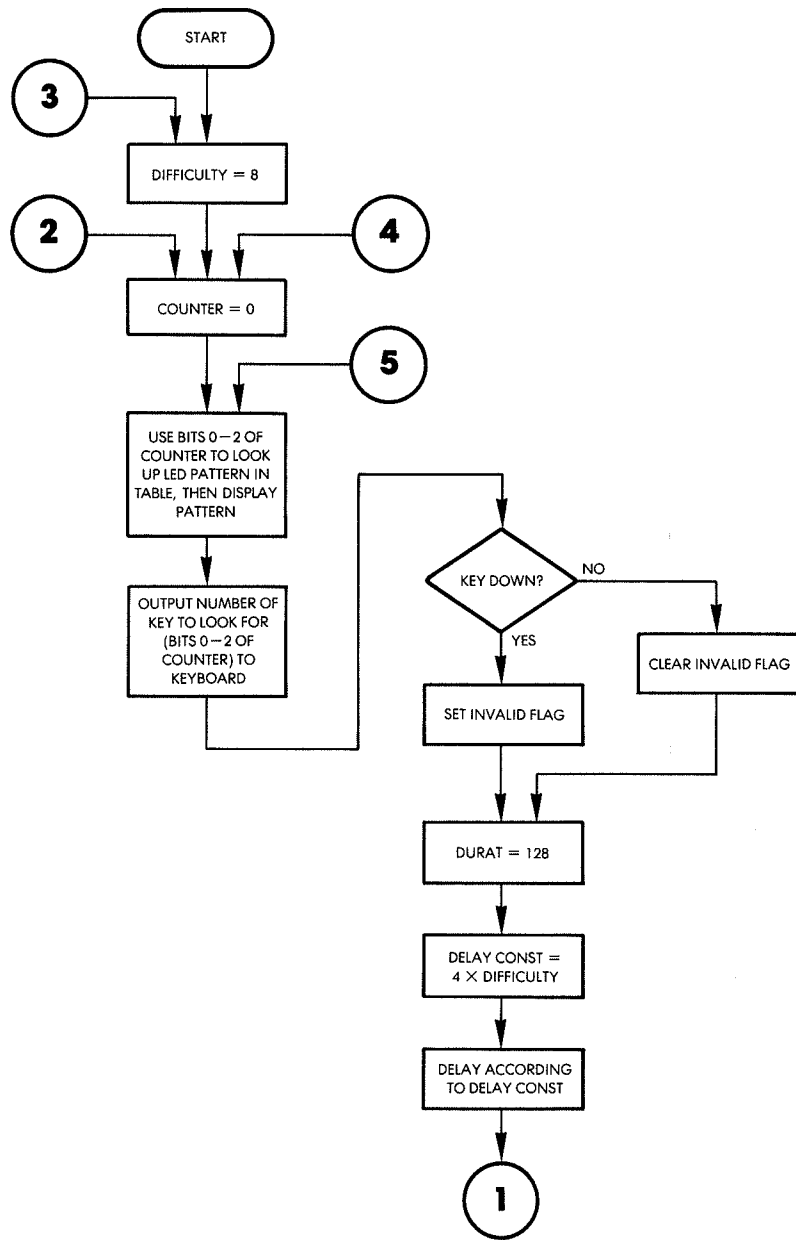

Fig. 6.1: Spinner Flowchart

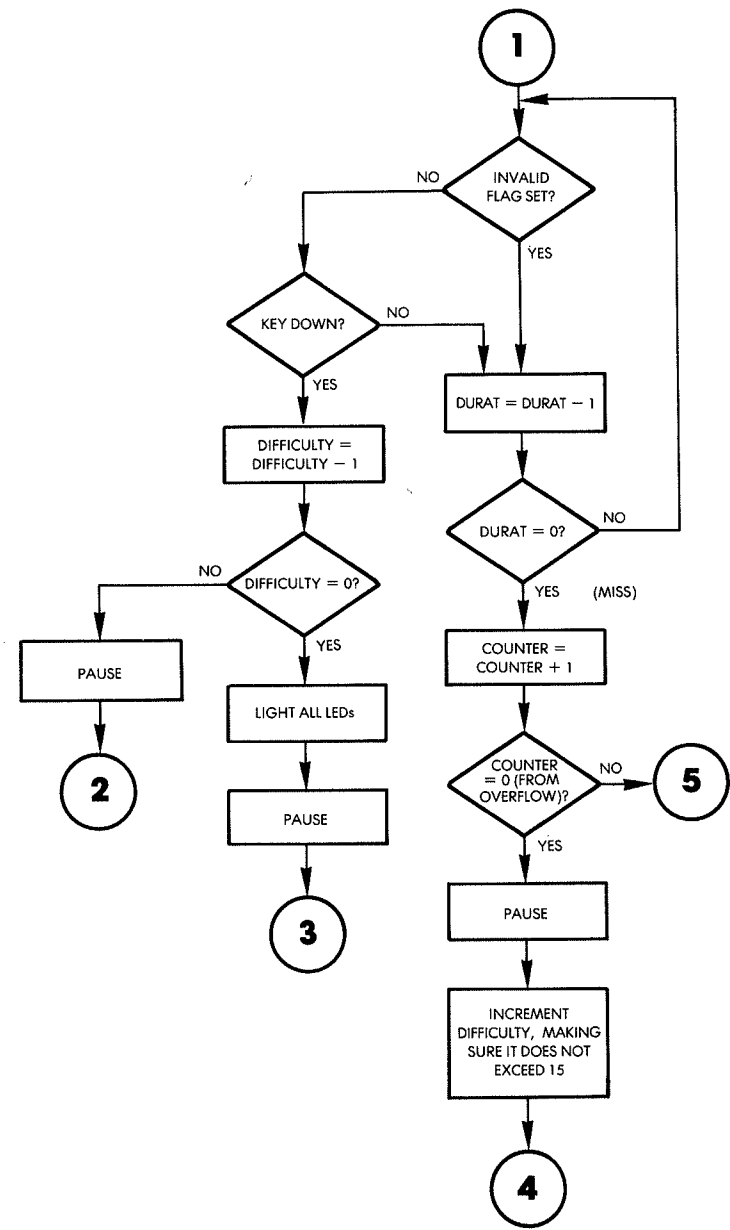

Fig. 6.1: Spinner Flowchart (Continued)

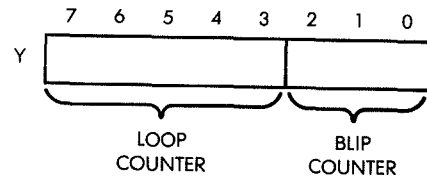

Fig. 6.2: Dual Counter

The difficulty level is set to 8, an average value:

```
LDA #8
STA DFCLT
```

The keystrobe port is conditioned for input:

```
STA DDR3A
```

The Y register, to be used as our generalized loop-plus-blip-counter, is set to "0":

```
NWGME LDY #0
```

The key-down indicator is also set to "0":

```
LOOP LDA #0
STA DNTST
```

LED #9 is cleared:

```
STA PORT1B
```

The lower 3 bits of the counter are extracted. They contain the blip-counter and are used as an index into the LED pattern table:

```
TYA          Y contains counter
AND #$07    Extract lower 3 bits
TAX         Use as index
```

The pattern is obtained from LTABL, using an indexed addressing

```
LINE # LOC CODE LINE
0002 0000 ; 'SPINNER'
0003 0000 ;PROGRAM TO TEST REACTION TIME OF PLAYER.
0004 0000 ;BLIP OF LIGHT SPINS AROUND EDGE
0005 0000 ;OF 3X3 LED MATRIX, AND USER MUST PRESS
0006 0000 ;CORRESPONDING KEY. IF, AFTER A NUMBER OF
0007 0000 ;SPINS, CORRECT KEY HAS NOT BEEN PRESSED,
0008 0000 ;BLIP SPINS SLOWER. IF CORRECT KEY HAS BEEN
0009 0000 ;PRESSED, BLIP SPINS FASTER. ALL
0010 0000 ;LEDS LIGHT WHEN SUCCESSFUL KEYPRESS
0011 0000 ;OCCURS ON MAXIMUM SPEED.
0012 0000 ;
0013 0000 ;I/O :
0014 0000 ;
0015 0000 PORT1A = $A001 ;LEDS 1-8
0016 0000 PORT1B = $A000 ;LEDS 8-15
0017 0000 DDR1A = $A003
0018 0000 DDR1B = $A002
0019 0000 PORT3A = $AC01 ;KEY STROBE INPUT.
0020 0000 PORT3B = $AC00 ;KEY # OUTPUT.
0021 0000 DDR3A = $AC03
0022 0000 DDR3B = $AC02
0023 0000 ;
0024 0000 ;VARIABLE STORAGE:
0025 0000 ;
0026 0000 * = $0
0027 0000 ;
0028 0000 DURAT **+1 ;DURATION OF INTER-MOVEMENT DELAY.
0029 0001 DIFCLT **+1 ;DIFFICULTY LEVEL.
0030 0002 DNTST **+1 ;SET TO #01 IF KEY DOWN AT START
0031 0003 ;OF INTER-MOVEMENT DELAY.
0032 0003 ;
0033 0003 ;TABLE OF PATTERNS TO BE SENT TO LED
0034 0003 ;MATRIX AT EACH LOOP COUNT.
0035 0003 ;SET FOR CLOCKWISE ROTATION STARTING AT LED #1.
0036 0003 ;
0037 0003 01 ;TABLE .BYTE $01,$02,$04,$20,$00,$80,$40,$08
0037 0004 02
0037 0005 04
0037 0006 20
0037 0007 00
0037 0008 80
0037 0009 40
0037 000A 0B
0038 000B ;
0039 000B ;TABLE OF PATTERNS TO BE SENT TO KEYBOARD
0040 000B ;TO TEST IF LEDES ARE ON AT EACH LOOP COUNT.
0041 000B ;
0042 000B 01 KYTBL .BYTE 1,2,3,6,9,8,7,4
0042 000C 02
0042 000D 03
0042 000E 06
0042 000F 09
0042 0010 0B
0042 0011 07
0042 0012 04
0043 0013 ;
0044 0013 ;MAIN PROGRAM
0045 0013 ;
0046 0013 * = $200
0047 0200 ;
0048 0200 A9 FF ;START LDA **FF ;SET I/O REGISTERS.
0049 0202 8D 03 A0 STA DDR1A
0050 0205 8D 02 A0 STA DDR1B
0051 0208 8D 02 AC STA DDR3B
0052 020B A9 08 LDA #8
0053 020D 85 01 STA DIFCLT ;SET DIFFICULTY.
0054 020F 8D 03 AC STA DDR3A ;SET KEYSTROBE PORT.
0055 0212 A0 00 NWGME LDY #0 ;RESET LOOP/BLIP COUNTER.
0056 0214 A9 00 LOOP LDA #0
0057 0216 85 02 STA DNTST ;CLEAR KEYDOWN INDICATOR.
0058 0218 8D 00 A0 STA PORT1B ;CLEAR HI LED PORT.
0059 021B 98 TYA ;USE LOWER 3 BITS OF MAIN COUNTER
0060 021C 29 07 AND **07 ;AS INDEX TO FIND LED PATTERN
0061 021E AA TAX ;IN TABLE OF PATTERNS.
0062 021F B5 03 LDA LTABLE,X ;GET PATTERN FOR LED TO
```

Fig. 6.3: Spinner Program

```

0063 0221          ;BE TURNED ON.
0064 0221 8D 01 A0 STA PORT1A ;STORE IN LED PORT.
0065 0224 D0 05   BNE CHECK ;IF PATTERN <> 0, SKIP.
0066 0226 A9 01   LDA #1 ;PATTERN=0, SO SET HI BIT.
0067 0228 8D 00 A0 STA PORT1B
0068 022B B5 08   CHECK LDA KYTBL,X ;GET KEY# TO TEST FOR.
0069 022D 8D 00 AC STA PORT3B ;STORE IN KEYPORT.
0070 0230 2C 01 AC BIT PORT3A ;STROBE HI?
0071 0233 30 04   BMI DELAY ;IF NOT, SKIP.
0072 0235 A9 01   INVALID LDA #01 ;STOBE HI: SET KEY DOWN MARKER.
0073 0237 85 02   DELAY STA DNTST
0074 0239 A9 80   DELAY LDA #$80 ;GET # OF LOOP CYCLES (DELAY LENGTH)
0075 023B 85 00   DELAY STA DURAT
0076 023D A5 01   DL1 LDA DIFCLT ;MULTIPLY DIFFICULTY COUNTER
0077 023F 0A      DL1 ASL A ;BY FOUR TO DETERMINE DELAY
0078 0240 0A      DL1 ASL A ;LENGTH.
0079 0241 AA      DL2 TAX
0080 0242 26 02   DL2 ROL DNTST ;DELAY ACCORDING TO DIFCLT.
0081 0244 66 02   DL2 ROR DNTST
0082 0246 CA      DEX
0083 0247 D0 F9   BNE DL2 ;LOOP 'TIL COUNT = 0
0084 0249 A5 02   LDA DNTST ;GET KEY DOWN FLAG.
0085 024B D0 05   BNE NOTST ;IF KEY WAS DOWN AT BEGINNING OF
0086 024D          ;DELAY, DON'T TEST IT.
0087 024D 2C 01 AC BIT PORT3A ;CHECK KEY STROBE.
0088 0250 10 19   NOTST BPL HIT ;KEY HAS CLOSED DURING DELAY: HIT.
0089 0252 C6 00   NOTST DEC DURAT ;COUNT DELAY LOOP DOWN.
0090 0254 D0 E7   NOTST BNE DL1 ;LOOP IF NOT 0.
0091 0256 C8      INY ;INCREMENT MAIN SPIN COUNTER.
0092 0257 D0 BB   BNE LOOP ;IF 32 LOOPS NOT DONE, DO NEXT LOOP
0093 0259 A6 01   LDX DIFCLT ;NO HITS THIS TIME, MAKE NEXT
0094 025B          ;EASIER.
0095 025B E8      INX
0096 025C 8A      TXA
0097 025D C9 10   CMP #16 ;MAKE SURE DIFFICULTY DOES NOT
0098 025F D0 02   BNE OK ;EXCEED 15
0099 0261 A9 0F   LDA #15
0100 0263 85 01   OK STA DIFCLT
0101 0265 20 80 02 JSR WAIT ;PAUSE A BIT.
0102 0268 4C 12 02 JMP NWGME ;START NEW ROUND.
0103 026B 20 80 02 HIT JSR WAIT ;PAUSE A BIT.
0104 026E C6 01   DEC DIFCLT ;MAKE NEXT GAME HARDER.
0105 0270 D0 A0   BNE NWGME ;IF DIFFICULTY NOT 0 (HARDEST),
0106 0272          ;PLAY NEXT GAME.
0107 0272 A9 FF   LDA #$FF ;PLAYER HAS MADE IT TO TOP
0108 0274 8D 01 A0 STA PORT1A ;DIFFICULTY LEVEL, LIGHT ALL LEDS.
0109 0277 8D 00 A0 STA PORT1B
0110 027A 20 80 02 JSR WAIT ;PAUSE A BIT.
0111 027D 4C 00 02 JMP START ;PLAY ANOTHER GAME.
0112 0280          ;
0113 0280          ;SUBROUTINE 'WAIT'
0114 0280          ;SHORT DELAY.
0115 0280          ;
0116 0280 A0 FF   WAIT LDY #$FF
0117 0282 A2 FF   LP1 LDX #$FF
0118 0284 66 00   LP2 ROR DURAT
0119 0286 26 00   LP2 ROL DURAT
0120 0288 66 00   LP2 ROR DURAT
0121 028A 26 00   LP2 ROL DURAT
0122 028C CA      DEX
0123 028D D0 F5   BNE LP2
0124 028F 88      DEY
0125 0290 D0 F0   BNE LP1
0126 0292 60      RTS
0127 0293          .END

```

SYMBOL TABLE

| SYMBOL | VALUE |
|---------|--|
| CHECK | 022B DDR1A A003 DDR1B A002 DDR3A AC03 |
| DDR3B | AC02 DELAY 0239 DIFCLT 0001 DL1 023D |
| DL2 | 0242 DNTST 0002 DURAT 0000 HIT 026B |
| INVALID | 0235 KYTBL 000B LOOP 0214 LP1 0282 |
| LP2 | 0284 LTABLE 0003 NOTST 0252 NWGME 0212 |
| OK | 0263 PORT1A A001 PORT1B A000 PORT3A AC01 |
| PORT3B | AC00 START 0200 WAIT 0280 |

END OF ASSEMBLY

Fig. 6.3: Spinner Program (Continued)

mechanism with register X, and this pattern is output on Port 1A to light up the appropriate LED:

```

LDA LTABLE, X   Get pattern
STA PORT1A      Use it to light up LED

```

As we indicated in the previous section, an explicit check must be made for the pattern "0," which requires that bit 0 of Port B be turned on. This corresponds to LED #9:

```

BNE CHECK      Was pattern = 0?
LDA #1         If not, set LED #9
STA PORT1B

```

Once the correct LED has been lit, the keyboard must be inspected to determine whether the player has already pressed the correct key. The program only checks the key number corresponding to the LED being lit:

```

CHECK          LDA KYTBL,X   X contains correct pointer
                STA PORT 3B   Select correct key
                BIT PORT 3A   Strobe hi?
                BMI DELAY     If not, skip

```

If the corresponding key is down (a strobe high on Port 3A is detected), the key-down flag, DNTST, is set to "1":

```

INVALID        LDA #01
                STA DNTST

```

This is an illegal key closure. It will be ignored. A delay to keep the LED lit is implemented by loading a value in memory location DURAT. This location is used as a loop-counter. It will be decremented later on and will cause a branch back to location DL1 to occur:

```

DELAY          LDA #$80
                STA DURAT

```

The difficulty counter, DIFCLT, is then multiplied by four. This is accomplished by two successive left shifts:

```
DL1      LDA DIFCLT
          ASL A
          ASL A
          TAX
```

The result is saved in index register X. It will determine the delay length. The lower the "difficulty-level," the shorter the delay will be.

The delay loop is then implemented:

```
DL2      ROL DNTST
          ROR DNTST
          DEX
          BNE DL2      Loop til count = 0
```

The key-down flag, DNTST, is then retrieved from memory and tested. If the key was down at the beginning of this routine, the program branches to location NOTST. Otherwise, if a closure is detected, a hit is reported and a branch occurs to location HIT:

```
LDA DNTST
BNE NOTST
BIT PORT3A      Check key strobe
BPL HIT
```

At NOTST, the external delay loop proceeds: the value of DURAT is decremented and a branch back to location DL1 occurs, unless DURAT decrements to "0." Whenever the delay decrements to "0" without a hit, the main counter (register Y) is incremented by 1. This results in advancing the blip-counter (lower three bits of register Y) to the next LED. However, if the blip-counter was pointing to LED #4 (the last one in our sequence), the loop-counter (upper 5 bits of register Y) will automatically be incremented by 1 when the blip-counter advances. If the value 32 is reached for the loop-counter, the value of register Y after incrementation will be "0" (in fact, an overflow will have occurred into the carry bit). This condition is tested explicitly:

```
NOTST    DEC DURAT
          BNE DL1      Loop if not 0
          INY          Increment counter
          BNE LOOP     32 loops?
```

Once the Y register has overflowed, i.e., 32 loops have been executed, the difficulty value is increased, resulting in a slower spin:

```
LDX DIFCLT      No hits. Make it easier
INX
```

The maximum difficulty level is 15, and this is tested explicitly:

```
TXA            Only A may be compared
CMP #16
BNE OK
LDA #15        Stay at 15 maximum
OK            STA DIFCLT
```

Finally, a brief pause is implemented:

```
JSR WAIT
```

and a new spin is started:

```
JMP NWGME
```

In the case of a hit, a pause is also implemented:

```
HIT        JSR WAIT
```

then the game is made harder by decrementing the difficulty count (DIFCLT)

```
DEC DIFCLT
```

The difficulty value is tested for "0" (fastest possible spin). If the "0" level has been reached, the player has won the game and all LEDs are illuminated:

```
BNE NWGME      If not 0, play next game
LDA #$FF       It is a win
STA PORT1A     Light up
STA PORT1B
```

The usual pause is implemented, and a new game is started:

```
JSR WAIT
JMP START
```

The pause is achieved with the usual delay subroutine called “WAIT.” It is a classic, two-level nested loop delay subroutine, with additional do-nothing instructions inserted at address 0286 to make it last longer:

```
WAIT      LDY #$FF
LP1       LDX #$FF
LP2       ROR DURAT
          ROL DURAT
          ROR DURAT
          ROL DURAT
          DEX
          BNE LP2
          DEY
          BNE LP1
          RTS
```

SUMMARY

This program implemented a game of skill. Multiple levels of difficulty were provided in order to challenge the player. Since human reaction time is slow, all delays were implemented as delay loops. For efficiency, a special double-counter was implemented in a single register: the blip counter—loop counter.

EXERCISES

Exercise 6-1: *There are several ways to “cheat” with this program. Any given key can be vibrated rapidly. Also, it is possible to press any number of keys simultaneously, thereby massively increasing the odds. Modify the above program to prevent these two possibilities.*

Exercise 6-2: *Change the rotation speed of the light around the LEDs by modifying the appropriate memory location. (Hint: this memory location has a name indicated at the beginning of the program.)*

Exercise 6-3: *Add sound effects.*

7

SLOT MACHINE

THE RULES

This program simulates a Las Vegas-type slot machine. The rotation of the wheels on a slot machine is simulated by three vertical rows of lights on LED columns 1-4-7, 2-5-8, and 3-6-9. The lights “rotate” around these three columns, and eventually stop. (See Figure 7.1.) The final light combination representing the player’s score is formed by LEDs 4-5-6, i.e., the middle horizontal row.

At the beginning of each game, the player is given eight points. The player’s score is displayed by the corresponding LED on the Games Board. At the start of each game, LED #8 is lit, indicating this initial score of 8.

The player starts the slot machine by pressing any key. The lights start spinning on the three vertical rows of LEDs. Once they stop, the combination of lights in LEDs 4, 5, and 6 determines the new score. If either zero or one LED is lit in this middle row, it is a lose situation, and the player loses one point. If two LEDs are lit in the middle row, the player’s score is increased by one point. If three LEDs are lit in the middle row, three points are added to the player’s score.

Whenever a total score of zero is obtained, the player has lost the game. The player wins the game when his or her score reaches 16 points. Everything that happens while the game is being played produces tones from the machine. While the LEDs are spinning, the speaker crackles, reinforcing the feeling of motion. Whenever the lights stop rotating, a tone sounds in the speaker, at a high pitch if it is a win situation, or at a low pitch if it is a lose situation. In particular, after a player takes his or her turn, if there are three lights in the mid-

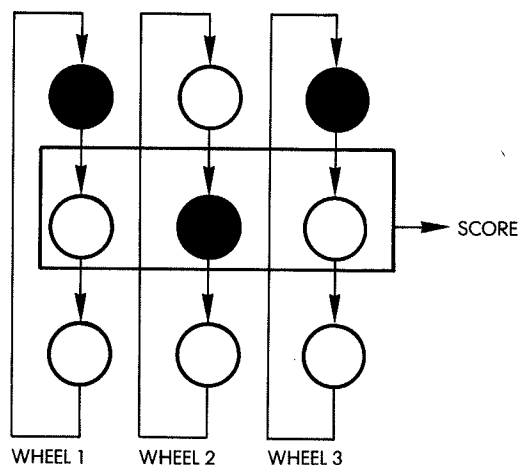

Fig. 7.1: The Slot Machine

dle row (a win situation), the speaker will go beep-beep-beep in a high pitch, to draw attention to the fact that the score is being incremented by three points. Whenever the maximum of 16 points is reached, the player has obtained a "jackpot." At this point all the LEDs on the board will light up simultaneously, and a siren sound will be generated (in ascending tones). Conversely, whenever a null score is reached, a siren will be sounded in descending tones.

Note that, unlike the Las Vegas model, this machine will let you win frequently! Good luck. However, as you know, it is not as much a matter of luck as it is a matter of programming (as in Las Vegas machines). You will find that both the scoring and the probabilities can be easily modified through programming.

A TYPICAL GAME

The Games Board initially displays a lit LED in position 8, indicating a starting score of 8. At this point the player should select and press a key. For this example let's press key 0. The lights start spinning. At the end of this spin, LEDs 4, 5, and 9 are lit. (See Figure 7.2.) This is a win situation and one point will be added to the score. The high-pitch tone sounds. LED #9 is then lit to indicate the total of the 8 previous points plus the one point obtained on this spin.

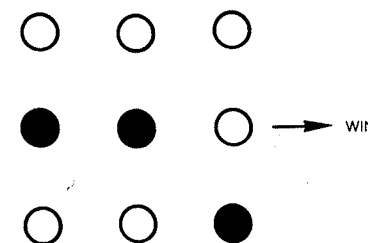

Fig. 7.2: A Win Situation

Key 0 is pressed again. This time only LED 5 in the middle row is lit after the spin. The score reverts back to 8. (Remember, the player loses 1 point from his or her score if either zero or only one LED in the middle row is lit after the spin.)

Key 0 is pressed again; this time LEDs 5 and 6 light up resulting in a score of nine.

Key 0 is pressed again. LED 4 is lit at the end of the spin, and LED 8 lights up again.

Key 0 is pressed. LED 6 is lit. The score is now 7, etc.

THE ALGORITHM

The basic sequencing for the slot machine program is shown in the flowchart in Figure 7.3. First, the score is displayed, then the game is started by the player's key stroke and the LEDs are spun. After this, the results are evaluated: the score is correspondingly updated and a win or lose situation is indicated.

The LED positions in a column are labeled 0, 1, 2, from the top to bottom. LEDs are spun by sequentially lighting positions 0, 1, 2, and then returning to position 0. The LEDs continue to spin in this manner and their speed of rotation diminishes until they finally come to a stop. This effect is achieved by incrementing the delay between each successive actuation of an LED within a given column. A counter-register is associated with each "wheel," or column of three LEDs. The initial contents of the three counters for wheels 1, 2, and 3 are obtained from a random number generator. In order to influence the odds, the random number must fit within a programmable bracket called (LOLIM, HILIM). The value of this counter is transferred to a temporary memory location. This location is regularly decremented until it reaches the value "0." When the value 0 is reached, the next LED on

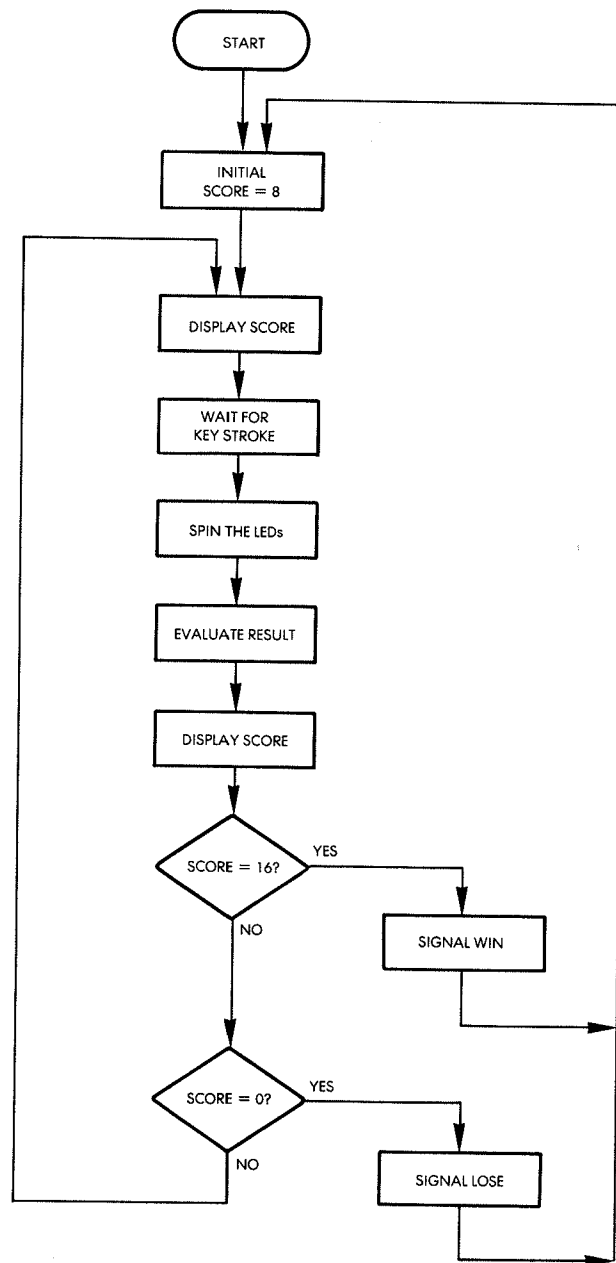

Fig. 7.3: Slots Flowchart

the “wheel” is lit. In addition, the original counter contents are incremented by one, resulting in a longer delay before lighting up the next LED. Whenever the counter overflows to 0, the process for that wheel stops. Thus, by using synchronous updating of the temporary memory locations, the effect of asynchronously moving LED “blips” is achieved. When all LEDs have stopped, the resulting position is evaluated.

The flowchart corresponding to this DISPLAY routine is shown in Figure 7.4. Let us analyze it. In steps 1, 2, and 3 the LED pointers are initialized to the top row of LEDs (position 0). The three counters used to supply the timing interval for each wheel are filled with numbers from a random number generator. The random number is selected between set limits. Finally, the three counters are copied into the temporary locations reserved for decrementing the delay constants.

Let us examine the next steps presented in Figure 7.4:

4. The wheel pointer X is set at the right-most column: $X = 3$.
5. The corresponding counter for the current column (column 3 this time) is tested for the value 0 to see if the wheel has stopped. It is not 0 the first time around.
- 6,7. The delay constant for the column of LEDs determined by the wheel pointer is decremented, then it is tested against the value 0. If the delay is not 0, nothing else happens for this column, and we move to the left by one column position:
 16. The column pointer X is decremented: $X = X - 1$
 17. X is tested against zero. If X is zero, a branch occurs to step 5. Every time that X reaches the value zero, the same situation may have occurred in all three columns. All wheel counters are, therefore, tested for the value zero.
18. If all counters are zero, the spin is finished and exit occurs. If all counters are not zero, a delay is implemented, and a branch back to (4) occurs.

Back to step 7:

7. If the delay constant has reached the value zero, the next LED down in the column must be lit.
8. The LED pointer for the wheel whose number is in the wheel pointer is incremented.
9. The LED pointer is tested against the value 4. If 4 has not been reached, we proceed; otherwise, it is reset to the value 1. (LEDs are designated externally by positions 1, 2, and 3 from

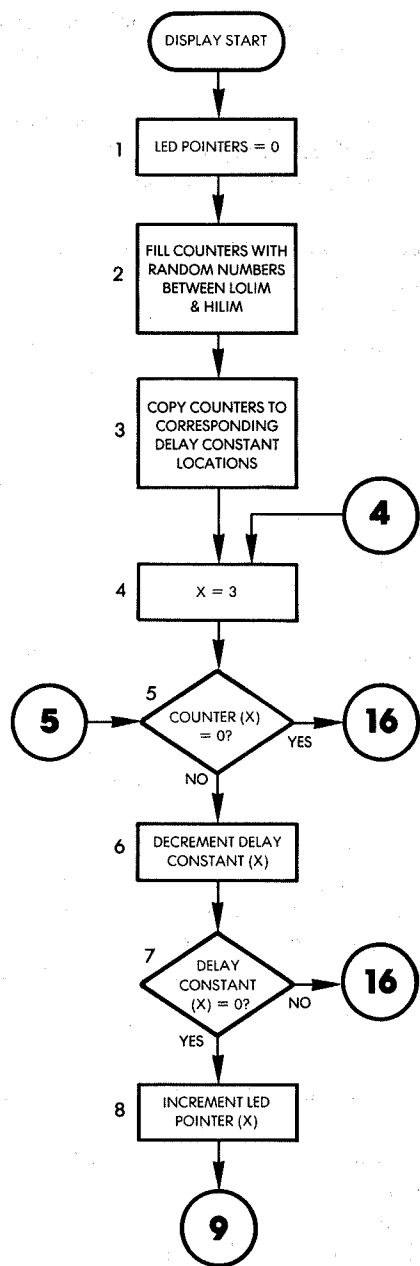

Fig. 7.4: DISPLAY Flowchart

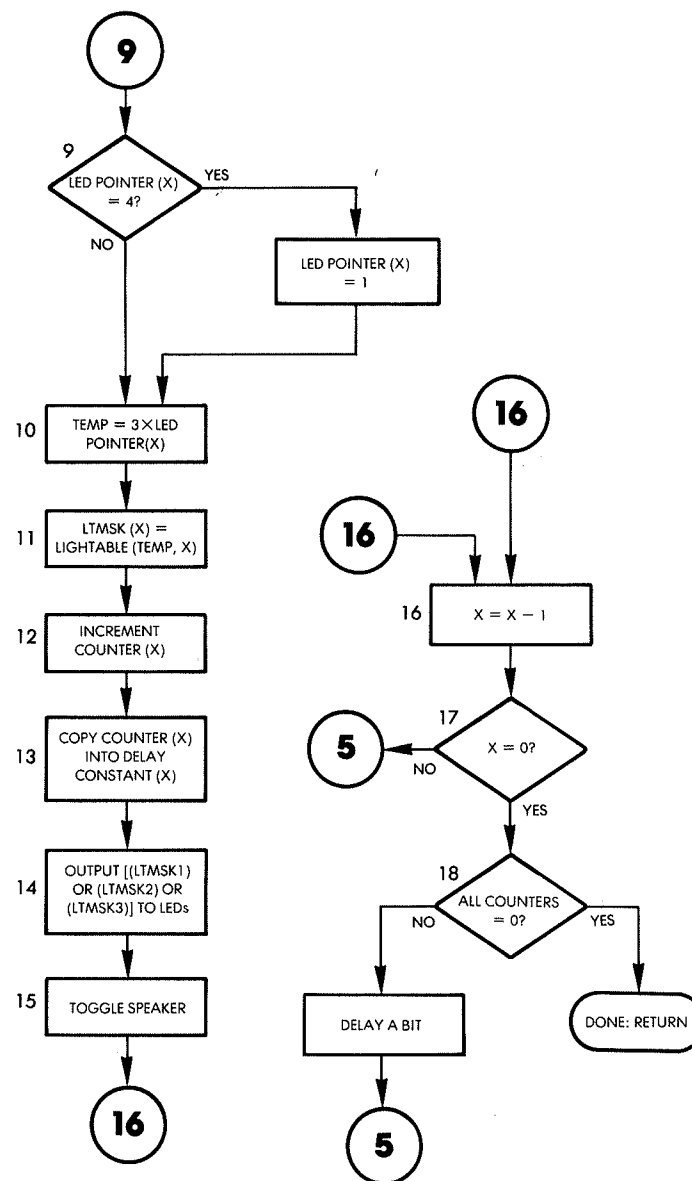

Fig. 7.4: DISPLAY Flowchart (Continued)

top to bottom. The next LED to be lit after LED #3 is LED #1.)

- 10,11. The LED must be lit on the board, and a table LIGHTABLE is utilized to obtain the proper pattern.
12. The counter for the appropriate wheel is incremented. Note that it is not tested against the value zero. This will occur only when the program moves to the left of wheel 1. This is done at location 18 in the flowchart, where the counters are tested for the value zero.
13. The new value of the counter is copied into the delay constant location, resulting in an increased delay before the next LED actuation.
14. The current lighting patterns of each column are combined and displayed.
15. As each LED is lit in sequence, the speaker is toggled (actuated) .
16. As usual, we move to the column on the left and proceed as before.

Let us go back to the test at step 5 in the flowchart:

5. Note that whenever the counter value for a column is zero, the LED in that column has stopped moving. No further action is required. This is accounted for in the flowchart by the arrow to the right of the decision box at 5: the branch occurs to 16 and the column pointer is decremented, resulting in no change for the column whose counter was zero.

Next, the evaluation algorithm must evaluate the results once all LEDs have stopped and then it must signal the results to the player. Let us examine it.

The Evaluation Process

The flowchart for the EVAL algorithm is shown in Figure 7.5. The evaluation process is also illustrated in Figure 7.6, which shows the nine LEDs and the corresponding entities associated with them. Referring to Figure 7.6, X is a row-pointer and Y is a column- or wheel-pointer. A value counter is associated with each row. It contains the total number of LEDs lit in that row. This value counter will be converted into a score according to specific rules for each row. So far, we have only used row 2 and have defined a winning situation as being one in which two or three LEDs were lit in that row. However, many other combinations are possible and are allowed by this mechanism.

Exercises will be suggested later for other winning patterns.

The total for all of the scores in each row is added into a total called SCORE, shown at the bottom right-hand corner of Figure 7.6.

Let us now refer to the flowchart in Figure 7.5. The wheel- or column pointer Y is set initially to the right-most column: $Y = 3$.

2. The temporary counters are initialized to the value zero.
3. Within the current column (3), we need only look at the row which has a lit LED. This row is pointed to by LED-POINTER. The corresponding row value is stored in: $X = \text{LED POINTER}(Y)$
4. Since an LED is lit in the row pointed to by X, the value counter for that row is incremented by one.

Assuming the LED situation of Figure 7.7, the second value counter has been set to the value 1.

5. The next column is examined: $Y = Y - 1$.

If Y is not 0, we go back to (3); otherwise the evaluation process may proceed to its next phase.

Exercise 7-1: Using the flowchart of Figure 7.5, and using the example of Figure 7.7, show the resulting values contained in the value counters when we finally exit from the test at (6) in the flowchart of Figure 7.5.

The actual number of LEDs lit in each row must now be transformed into a score. The SCORETABL is used for that purpose. If the scoring rules contained in this table are changed, they will completely modify the way the game is played.

The score table contains four byte-long numbers per row. Each number corresponds to the score to be earned by the player when 0, 1, 2, or 3 LEDs are lit in that row. The logical organization of the score table is shown in Figure 7.8. The entries in the table correspond to the score values which have been selected for the program presented at the beginning of this chapter. Any combination of LEDs in rows 1 or 3 scores 0. Any combination of 2 LEDs in row 2 scores 1, but, three LEDs score 3. Practically, this means that the score value of row 1 is obtained by merely using an indexed access technique with the number of LEDs lit as the index. For row 2, a displacement of four must be added for table access. In row 3, an additional displacement of four must be added. Mathematically, this translates to:

$$\text{SCORE} = \text{SCORETABL}[(X - 1) \times 4 + 1 + Y]$$

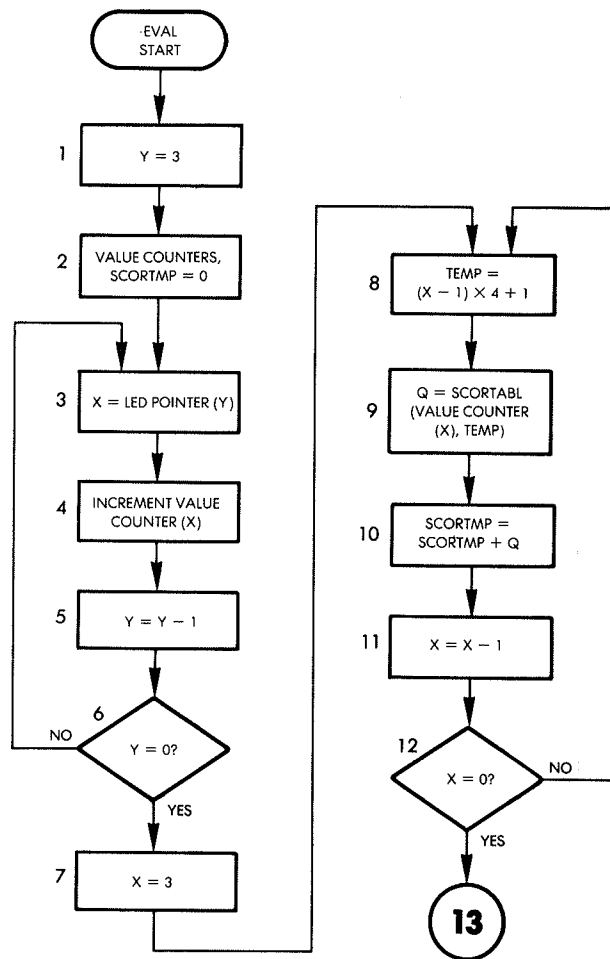

Fig. 7.5: EVAL Flowchart

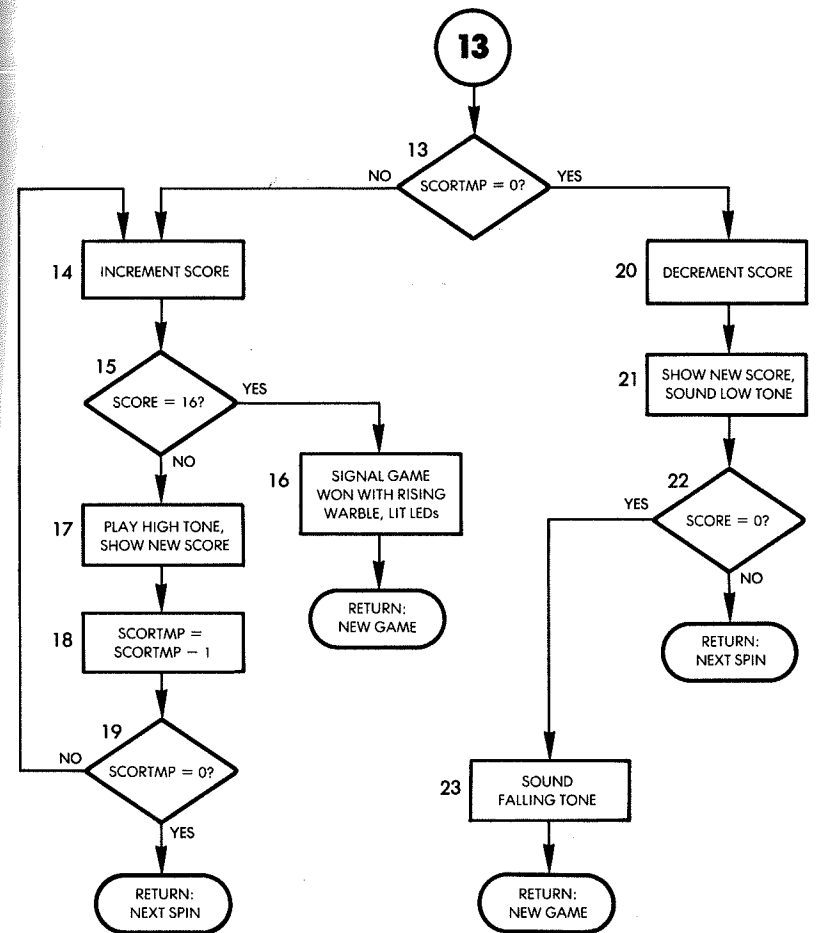

Fig. 7.5: EVAL Flowchart (Continued)

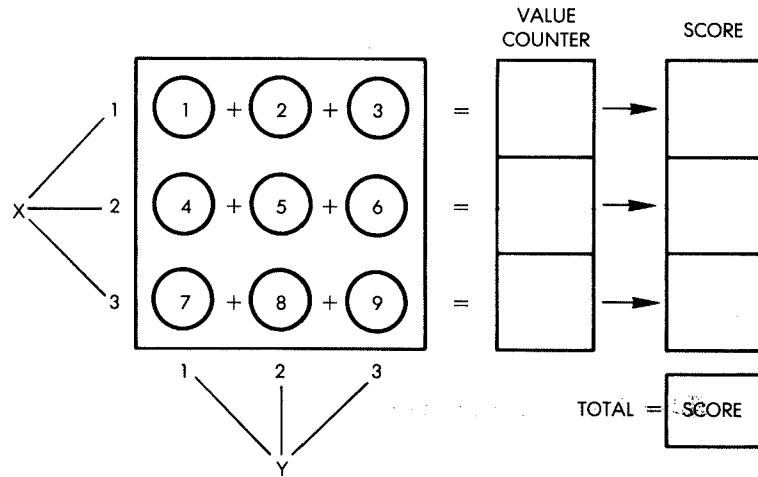

Fig. 7.6: Evaluation Process on the Board

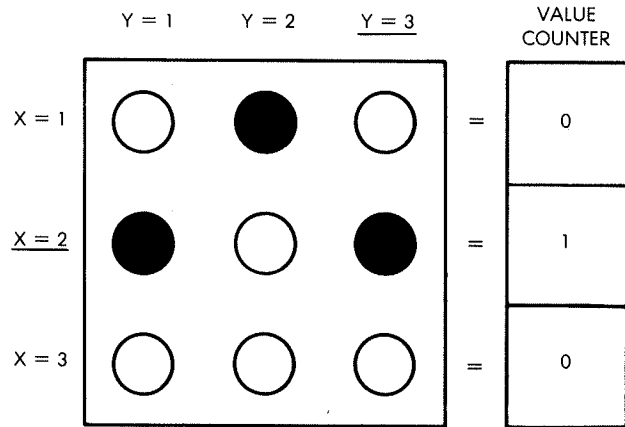

Fig. 7.7: An Evaluation Example

where X is the row number and Y is the number of LEDs lit for that row. Since this technique allows each of the three rows to generate a score, the program must test the value counter in each row to obtain the total score.

This is accomplished by steps 7 and 8: the row pointer is initialized

| | 0 | 1 | 2 | 3 | NUMBER LEDs LIT |
|-------|---|---|---|---|-----------------|
| ROW 1 | 0 | 0 | 0 | 0 | |
| ROW 2 | 0 | 0 | 1 | 3 | |
| ROW 3 | 0 | 0 | 0 | 0 | |

Fig. 7.8: The Score Table

to 3, and a score table displacement pointer is set up:

$$TEMP = (X - 1) \times 4 + 1$$

9. Next, the value of the score is obtained from the table:

$$Q = SCORTABL(\text{value counter}(X), TEMP)$$

The value of that row's score is obtained by accessing the score table indexed by the number of LEDs lit, contained in the value counter for that row, plus a displacement equal to TEMP. The intermediate score is obtained by adding this partial score to any previous value:

10. $SCORTMP = SCORTMP + Q$
11. Finally, the row number is decremented, and the process is repeated until X reaches the value 0.
12. Whenever X reaches the value 0, the score for this spin has been computed and stored in location SCORTMP.
13. At this point, the score computed above (SCORTMP) is examined by the program, and two possibilities exist: if the SCORTMP is 0, a branch occurs to 20, where the game score is decremented. If SCORTMP is not 0, the game score will be increased by the score for this spin — SCORTMP. Let us follow this path first.
14. The total game score is incremented by one.
15. It is then tested for the maximum value of 16.

16. If the maximum score of 16 is reached in step 15, a special audible and visual signal is generated to reward the player. A new game may be started.
17. If 16 is not reached in step 15, the updated game score is shown to the player, accompanied by a high-pitched tone.
18. The amount by which the game score must be increased, SCORTMP, is decremented.
19. If SCORTMP is not zero, more points must be added to the game score, and a branch occurs to 14. Otherwise, the player may enter the next spin.

Let us now follow the other path from position thirteen on the flowchart, where the total score had been tested:

20. The score for this spin is 0, so the game score is decremented.
21. It is displayed to the player along with a low tone.
22. The new score is tested for the minimum value 0. If this minimum value has been reached, the player has lost. Otherwise, the player may keep playing.
23. A descending siren-type tone is generated to indicate the loss, and the game ends.

THE PROGRAM

Data Structures

Two tables are used by this program: 1) the score table is used to compute a score from the number of LEDs lit in each row — this has already been described; 2) the LTABLE is used to generate the appropriate code on the I/O port to light the specified LED. Each entry within this table contains a pattern to be OR'ed into the I/O register to light the specified LED.

Vertically, in the memory, the table entries correspond to the first column, the second column, and then the third column of LEDs. Looking at the program on lines 39, 40, and 41, the rows of digits correspond respectively to the columns of LEDs. For example, the third entry in the table, i.e., 64 decimal, or 40 hexadecimal (at address 001C) corresponds to the third LED in the first column on the Games Board, or LED 7.

Page Zero Variables

The following variables are stored in memory:
— TEMP is a scratch location

```

LINE # LOC      CODE      LINE
0002 0000          ;SLOT MACHINE SIMULATOR PROGRAM.
0003 0000          ;PRESS ANY KEY TO START 'SPIN'.
0004 0000          ;SCORE DETERMINED BY ARRAY 'SCORTB'.
0005 0000          ;8 POINTS INITIAL SCORE, ONE POINT PENALTY
0006 0000          ;FOR EACH BAD SPIN.
0007 0000          ;
0008 0000          * = $0
0009 0000          TEMP * = *+1          ;TEMPORARY STORAGE.
0010 0001          SCORTP * = *+1        ;TEMPORARY SCORE STORAGE.
0011 0002          SCORE * = *+1       ;SCORE.
0012 0003          DUR * = *+1         ;DURATION OF TONES.
0013 0004          FREQ * = *+1        ;FREQUENCY OF TONES.
0014 0005          SPEEDS * = *+3      ;SPEEDS OF REVOLUTION FOR LEDS
0015 0008          ;IN COLUMNS
0016 0008          INDX * = *+3        ;DELAY COUNTERS FOR LED REVOLUTIONS.
0017 0008          INCR * = *+3        ;POINTERS FOR LED POSITIONS.
0018 000E          ;USED TO FETCH PATTERNS OUT OF TABLES.
0019 000E          LTMSK * = *+3       ;PATTERNS FOR LIT LEDS
0020 0011          VALUES * = *+3     ;NO. OF LIT LEDS IN EACH ROW.
0021 0014          RND * = *+6         ;SCRATCHPAD FOR RND # GEN.
0022 001A          ;
0023 001A          ;I/O
0024 001A          ;
0025 001A          PORT1A = $A001      ;VIA#1 PORT A I/O REG (LEDS)
0026 001A          DDR1A = $A003      ;VIA#1 PORT A DATA DIRECTION REG.
0027 001A          PORT1B = $A000     ;VIA#1 PORT B I/O REG. (LEDS)
0028 001A          DDR1B = $A002     ;VIA#1 PORT B DATA DIRECTION REG.
0029 001A          PORT3B = $A000     ;VIA#3 PORT B I/O REG. (SPKR)
0030 001A          DDR3B = $A002     ;VIA#3 PORT B DATA DIRECTION REG.
0031 001A          TICL = $A004
0032 001A          ;
0033 001A          ;ARRAYS
0034 001A          ;
0035 001A          ;ARRAY OF PATTERNS TO LIGHT LEDS.
0036 001A          ;ARRAY ROWS CORRESPOND TO COLUMNS OF LED
0037 001A          ;ARRAY, AND COLUMNS TO ROWS. FOR EXAMPLE, THIRD
0038 001A          ;BYTE IN ROW ONE WILL LIGHT LED 7.
0039 001A          01
0039 001B          08
0039 001C          40
0040 001D          02          .BYTE 2,16,128
0040 001E          10
0040 001F          80
0041 0020          04          .BYTE 4,32,0
0041 0021          20
0041 0022          00
0042 0023          ;
0043 0023          ;ARRAY OF SCORES RECEIVED FOR CERTAIN
0044 0023          ;PATTERNS OF LIT LEDS.
0045 0023          ;ROWS CORRESPOND TO ROWS IN LED ARRAY.
0046 0023          ;COLUMNS CORRESPOND TO NUMBER OF LEDS
0047 0023          ;LIT IN THAT ROW.
0048 0023          ;I.E., 3 LEDS IN MIDDLE ROW IS 3 PTS.
0048 0023          00          SCORTB .BYTE 0,0,0,0
0048 0024          00
0048 0025          00
0048 0026          00
0049 0027          00          .BYTE 0,0,1,3
0049 0028          00
0049 0029          01
0049 002A          03
0050 002B          00          .BYTE 0,0,0,0
0050 002C          00
0050 002D          00
0050 002E          00
0051 002F          ;
0052 002F          ;***** MAIN PROGRAM *****
0053 002F          ;
0054 002F          GETKEY = $100
0055 002F          * = $200
0056 0200          A9 FF          LDA #$FF          ;SET UP PORTS.

```

Fig. 7.9: Slot Machine Program

```

0057 0202 8D 03 A0      STA DDR1A
0058 0205 8D 02 A0      STA DDR1B
0059 0208 8D 02 AC      STA DDR3B
0060 020B AD 04 A0      LDA TICL          ;GET SEED FOR RANDOM # GEN.
0061 020E 85 15          STA RND+1
0062 0210 A9 08          LDA #8            ;INITIAL SCORE IS EIGHT.
0063 0212 85 02          STA SCORE
0064 0214 A8            TAY              ;SHOW INITIAL SCORE
0065 0215 20 3D 03      JSR LIGHT
0066 0218 20 00 01      KEY JSR GETKEY     ;ANY KEY PRESSED STARTS PROGRAM.
0067 021B 20 27 02      JSR DISPLY       ;SPIN WHEELS
0068 021E 20 A7 02      JSR EVAL         ;CHECK SCORE AND SHOW IT
0069 0221 A5 02          LDA SCORE
0070 0223 D0 F3          BNE KEY          ;IF SCORE <> 0, GET NEXT PLAY.
0071 0225 F0 E9          BEQ START       ;IF SCORE = 0, RESTART.
0072 0227                ;
0073 0227                ;SUBROUTINE TO DISPLAY 'SPINNING' LEDS,
0074 0227                ;FIND COMBINATION TO USED TO DETERMINE SCORE.
0075 0227                ;
0076 0227                ;
0077 0227                ;
0078 0227                ;
0079 0227 A9 00          DISPLY LDA #0    ;RESET POINTERS.
0080 0229 85 0B          STA INCR
0081 022B 85 0C          STA INCR+1
0082 022D 85 0D          STA INCR+2
0083 022F A0 02          LDRND LDY #2     ;SET INDEX FOR 3 ITERATIONS.
0084 0231 20 80 03      GETRND JSR RANDOM  ;GET RANDOM #.
0085 0234 C9 87          CMP #HILIM       ;TOO LARGE?
0086 0236 B0 F9          BCS GETRND       ;IF SO, GET ANOTHER.
0087 0238 C9 5A          CMP #LOLIM       ;TOO SMALL?
0088 023A 90 F5          BCC GETRND       ;IF SO, GET ANOTHER.
0089 023C 99 08 00      STA INDX,Y       ;SAVE IN LOOP INDEXES AND
0090 023F 99 05 00      STA SPEEDS,Y    ;LOOP SPEED COUNTERS.
0091 0242 88            DEY
0092 0243 10 EC          BPL GETRND       ;GET NEXT RND #.
0093 0245 A2 02          UPDATE LDX #2    ;SET INDEX FOR THREE ITERATIONS.
0094 0247 B4 05          UPDTLP LDY SPEEDS,X ;IS SPEED(X)=0?
0095 0249 F0 44          BEQ NXTUPD      ;IF SO, DO NEXT UPDATE.
0096 024B D6 08          DEC INDX,X       ;DECREMENT LOOP INDEX(X)
0097 024D D0 40          BNE NXTUPD      ;IF LOOPINDEX(X) <> 0,
0098 024F                ;DO NEXT UPDATE.
0099 024F B4 0B          LDY INCR,X       ;INCREMENT POINTER(X).
0100 0251 C8            INY
0101 0252 C0 03          CPY #3           ;POINTER = 3?
0102 0254 D0 02          BNE NORST       ;IF NOT SKIP...
0103 0256 A0 00          LDY #0           ;...RESET OF POINTER TO 0.
0104 0258 94 0B          NORST STY INCR,X   ;RESTORE POINTER(X).
0105 025A 86 00          STX TEMP        ;MULTIPLY X BY 3 FOR ARRAY ACCESS.
0106 025C 8A            TXA
0107 025D 0A            ASL A
0108 025E 18            CLC
0109 025F 65 00          ADC TEMP
0110 0261 75 0B          ADC INCR,X       ;ADD COLUMN# TO PTR(X) FOR ROW#.
0111 0263 AB            TAY
0112 0264 B9 1A 00      LDA LTABLE,Y     ;GET PATTERN FOR LED.
0113 0267 95 0E          STA LTMASK,X    ;STORE IN LIGHT MASK(X).
0114 0269 B4 05          SPDUPD LDY SPEEDS,X    ;INCREMENT SPEED(X).
0115 026B C8            INY
0116 026C 94 05          STY SPEEDS,X    ;RESTORE.
0117 026E 94 08          STY INDX,X      ;RESET LOOP INDEX(X).
0118 0270 A9 00          LEDUPD LDA #0          ;UPDATE LIGHTS.
0119 0272 8D 00 A0      STA PORT1B      ;RESET LED #9
0120 0275 A5 10          LDA LTMASK+2    ;COMBINE PATTERNS FOR OUTPUT.
0121 0277 D0 07          BNE OFFLD9     ;IF MASK#3 <> 0, LED 9 OFF.
0122 0279 A9 01          LDA #01         ;TURN ON LED 9.
0123 027B 8D 00 A0      STA PORT1B
0124 027E A9 00          LDA #0          ;RESET A SO PATTERN WON'T BE BAD.
0125 0280 05 0E          OFFLD9 ORA LTMASK ;COMBINE REST OF PATTERNS.
0126 0282 05 0F          ORA LTMASK+1
0127 0284 8D 01 A0      STA PORT1A      ;SET LIGHTS.
0128 0287 AD 00 AC      LDA PORT3B      ;TOGGLE SPEAKER.

```

Fig. 7.9: Slot Machine Program (Continued)

```

0129 028A 49 FF          EOR #FF
0130 028C 8D 00 AC      STA PORT3B
0131 028F CA            NXTUPD DEX      ;DECREMENT X FOR NEXT UPDATE.
0132 0290 10 B5          BPL UPDTLP      ;IF X=0, DO NEXT UPDATE.
0133 0292 A0 5D          LDY #SPDPRM    ;DELAY A BIT TO SLOW
0134 0294 88            DEY             ;FLASHING OF LEDS.
0135 0295 D0 FD          BNE WAIT
0136 0297 A5 05          LDA SPEEDS      ;CHECK IF ALL COLUMNS OF
0137 0299                ;LEDS STOPPED.
0138 0299 05 06          ORA SPEEDS+1
0139 029B 05 07          ORA SPEEDS+2
0140 029D D0 A6          BNE UPDATE     ;IF NOT, DO NEXT SEQUENCE
0141 029F                ;OF UPDATES.
0142 029F A9 FF          LDA #FF
0143 02A1 85 03          STA DUR        ;DELAY TO SHOW USER PATTERN.
0144 02A3 20 30 03      JSR DELAY
0145 02A6 60            RTS             ;ALL LEDS STOPPED, DONE.
0146 02A7                ;
0147 02A7                ;SUBROUTINE TO EVALUATE PRODUCT OF SPIN, AND
0148 02A7                ;DISPLAY SCORE W/ TONES FOR WIN, LOSE, WIN+ENDGAME,
0149 02A7                ;AND LOSE+ENDGAME.
0150 02A7                ;
0151 02A7                ;
0152 02A7                ;
0153 02A7 A9 00          LOTONE = $F0
0154 02A9 85 11          EVAL LDA #0      ;RESET VARIABLES.
0155 02AB 85 12          STA VALUES
0156 02AD 85 13          STA VALUES+1
0157 02AF 85 01          STA SCORTP
0158 02B1 A0 02          LDY #2         ;SET INDEX Y FOR 3 ITERATIONS
0159 02B3                ;TO COUNT # OF LEDS ON IN EACH ROW.
0160 02B3 B6 0B          CNTLP LDX INCR,Y ;CHECK POINTER(Y), ADDING
0161 02B5 F6 11          INC VALUES,X  ;UP # OF LEDS ON IN EACH ROW.
0162 02B7 88            DEY
0163 02B8 10 F9          BPL CNTLP      ;LOOP IF NOT DONE.
0164 02BA A2 02          LDX #2 SET INDX X FOR 3 ITERATIONS.
0165 02BC                ;OF LOOP TO FIND SCORE.
0166 02BC 8A            SCORLP TXA     ;MULTIPLY INDEX BY FOUR FOR ARRAY
0167 02BD                ;ROW ACCESS.
0168 02BD 0A            ASL A
0169 02BE 0A            ASL A
0170 02BF 18            CLC             ;ADD # OF LEDS ON IN ROW(X) TO...
0171 02C0 75 11          ADC VALUES,X  ;...ARRIVE AT COLUMN ADDRESS IN ARRAY.
0172 02C2 A8            TAY
0173 02C3 B9 23 00      LDA SCORTR,Y   ;GET SCORE FOR THIS SPIN.
0174 02C6 18            CLC
0175 02C7 65 01          ADC SCORTP     ;ADD TO ANY PREVIOUS SCORES
0176 02C9                ;ACCUMULATED IN THIS LOOP.
0177 02C9 85 01          STA SCORTP    ;RESTORE
0178 02CB CA            DEX
0179 02CC 10 EE          BPL SCORLP     ;LOOP IF NOT DONE
0180 02CE A9 60          LDA #60 SET UP DURATIONS FOR TONES.
0181 02D0 85 03          STA DUR
0182 02D2 A5 01          LDA SCORTP     ;GET SCORE FOR THIS SPIN.
0183 02D4 F0 34          BEQ LOSE       ;IF SCORE IS 0, LOSE A POINT.
0184 02D6 E6 02          WIN INC SCORE   ;RAISE OVERALL SCORE BY ONE.
0185 02D8 A4 02          LDY SCORE
0186 02DA C0 10          CPY #16       ;WIN W/ 16 PTS?
0187 02DC F0 10          BEQ WINEND    ;YES : WIN+ENDGAME.
0188 02DE 20 3D 03      JSR LIGHT     ;SHOW SCORE.
0189 02E1 A9 20          LDA #HITONE   ;PLAY HIGH BEEP.
0190 02E3 20 64 03      JSR TONE
0191 02E6 20 30 03      JSR DELAY     ;SHORT DELAY.
0192 02E7 C6 01          DEC SCORTP    ;DECREMENT SCORE TO BE ADDED TO...
0193 02E8                ;OVERALL SCORE BY ONE.
0194 02EB D0 E9          BNE WIN
0195 02ED 60            RTS
0196 02EE A9 FF          WINEND LDA #FF  ;LOOP IF SCORE XFER NOT COMPLETE.
0197 02F0 8D 01 A0      STA PORT1A    ;DONE, RETURN TO MAIN PROGRAM.
0198 02F3 8D 00 A0      STA PORT1B    ;TURN ALL LEDS ON TO SIGNAL WIN.
0199 02F6 85 00          STA TEMP
0200 02F8 A9 00          LDA #0
0201 02FA 85 02          STA SCORE     ;SET FREQ PARM FOR RISING WARBLE.
                ;CLEAR TO FLAG RESTART.

```

Fig. 7.9: Slot Machine Program (Continued)

```

0202 02FC A9 04      LDA #4          ;SHORT DURATION FOR INDIVIDUAL
0203 02FE 85 03      STA DUR        ;SHORT DURATION FOR INDIVIDUAL
0204 0300            ;BEEPS IN WARBLE.
0205 0300 A5 00      RISE LDA TEMP    ;GET FREQUENCY....
0206 0302 20 64 03  JSR TONE      ;....FOR BEEP.
0207 0305 C6 00      DEC TEMP      ;NEXT BEEP WILL BE HIGHER.
0208 0307 D0 F7      BNE RISE     ;DO NEXT BEEP IF NOT DONE.
0209 0309 60          RTS          ;RETURN FOR RESTART.
0210 030A C6 02      LOSE DEC SCORE  ;IF SPIN BAD, SCORE=SCORE-1
0211 030C A4 02      LDY SCORE    ;SHOW SCORE
0212 030E 20 3D 03  JSR LIGHT
0213 0311 A9 F0      LDA #LOTONE   ;PLAY LOW LOSE TONE.
0214 0313 20 64 03  JSR TONE
0215 0316 A4 02      LDY SCORE    ;GET SCORE TO SEE ....
0216 0318 F0 01      BEQ LOSEND  ;IF GAME IS OVER.
0217 031A 60          RTS          ;IF NOT, RETURN FOR NEXT SPIN.
0218 031B A9 00      LOSEND LDA #0   ;SET TEMP FOR USE AS FREQ PARM
0219 031D 85 00      STA TEMP     ;IN FALLING WARBLE.
0220 031F 8D 01 A0  STA PORT1A   ;CLEAR LED #1.
0221 0322 A9 04      LDA #4
0222 0324 85 03      STA DUR
0223 0326 A5 00      FALL LDA TEMP  ;PLAY BEEP.
0224 0328 20 64 03  JSR TONE
0225 032B E6 00      INC TEMP    ;NEXT TONE WILL BE LOWER.
0226 032D D0 F7      BNE FALL
0227 032F 60          RTS          ;RETURN FOR RESTART.
0228 0330            ;
0229 0330            ;VARIABLE LENGTH DELAY SUBROUTINE.
0230 0330            ;DELAY LENGTH = (2046*(CONTENTS OF DUR)+10) US.
0231 0330            ;
0232 0330 A4 03      DELAY LDY DUR  ;GET DELAY LENGTH.
0233 0332 A2 FF      DL1  LDX #FFF  ;SET CNTR FOR INNER 2040 US. LOOP
0234 0334 D0 00      DL2  BNE #+2  ;WASTE TIME.
0235 0336 CA          DEX          ;DECREMENT INNER LOOP CNTR.
0236 0337 D0 FB      BNE DL2   ;LOOP 'TILL INNER LOOP DONE.
0237 0339 88          DEY          ;DECREMENT OUTER LOOP CNTR.
0238 033A D0 F6      BNE DL1   ;LOOP 'TILL DONE.
0239 033C 60          RTS          ;RETURN.
0240 033D            ;
0241 033D            ;SUBROUTINE TO LIGHT LED CORRESPONDING
0242 033D            ;TO THE CONTENTS OF REGISTER Y ON ENTERING.
0243 033D            ;
0244 033D A9 00      LIGHT LDA #0   ;CLEAR REG. A FOR BIT SHIFT.
0245 033F 85 00      STA TEMP    ;CLEAR OVERFLOW FLAG.
0246 0341 8D 01 A0  STA PORT1A   ;CLEAR LOW LED.
0247 0344 8D 00 A0  STA PORT1B   ;CLEAR HIGH LED.
0248 0347 C0 0F      CPLY #15  ;CODE FOR UNCONNECTED BIT?
0249 0349 F0 01      BEQ #+3   ;IF SO, NO CHNG.
0250 034B 88          DEY          ;DECREMENT TO MATCH.
0251 034C 38          SEC          ;SET BIT TO BE SHIFTED HIGH.
0252 034D 2A          LSHFT ROL A   ;SHIFT BIT LEFT.
0253 034E 90 05      BCC LTCC   ;IF CARRY SET, OVERFLOW HAS
0254 0350            ;OCCURRED INTO HIGH BYTE.
0255 0350 A2 FF      LDX #FFF  ;SET OVERFLOW FLAG.
0256 0352 86 00      STX TEMP
0257 0354 2A          ROL A       ;MOVE BIT OUT OF CARRY.
0258 0355 88          DEY          ;ONE LESS BIT TO BE SHIFTED.
0259 0356 10 F5      BPL LSHFT  ;SHIFT AGAIN IF NOT DONE.
0260 0358 A6 00      LDX TEMP    ;GET OVERFLOW FLAG.
0261 035A D0 04      BNE HIBYTE ;IF FLAG<0, OVERFLOW: A CONTAINS
0262 035C            ;HIGH BYTE.
0263 035C 8D 01 A0  LOBYTE STA PORT1A ;STORE A IN LOW ORDER LED.
0264 035F 60          RTS          ;RETURN.
0265 0360 8D 00 A0  HIBYTE STA PORT1B ;STORE A IN HIGH ORDER LED.
0266 0363 60          RTS          ;RETURN.
0267 0364            ;
0268 0364            ;TONE GENERATION SUBROUTINE.
0269 0364            ;
0270 0364 85 04      TONE  STA FREQ
0271 0366 A9 FF      LDA #FFF
0272 0368 8D 00 AC  STA PORT3B
0273 036B A9 00      LDA #00

```

Fig. 7.9: Slot Machine Program (Continued)

```

0274 036D A6 03      LDX DUR
0275 036F A4 04      FL2  LDY FREQ
0276 0371 88          FL1  DEY
0277 0372 18          CLC
0278 0373 90 00      BCC #+2
0279 0375 D0 FA      BNE FL1
0280 0377 49 FF      EOR #FFF
0281 0379 8D 00 AC  STA PORT3B
0282 037C CA          DEX
0283 037D D0 F0      BNE FL2
0284 037F 60          RTS
0285 0380            ;
0286 0380            ;RANDOM NUMBER GENERATOR SUBROUTINE.
0287 0380            ;
0288 0380 38          RANDOM SEC
0289 0381 A5 15      LDA RND+1
0290 0383 65 18      ADC RND+4
0291 0385 65 19      ADC RND+5
0292 0387 85 14      STA RND
0293 0389 A2 04      LDX #4
0294 038B B5 14      RND$H LDA RND,X
0295 038D 95 15      STA RND+1,X
0296 038F CA          DEX
0297 0390 10 F9      BPL RND$H
0298 0392 60          RTS
0299 0393            .END

```

SYMBOL TABLE

| SYMBOL | VALUE | | | | | |
|-----------------|-------|--------|------|--------|------|--------|
| CNTLP | 02B3 | DDR1A | A003 | DDR1B | A002 | DDR3B |
| DELAY | 0330 | DISPLY | 0227 | DL1 | 0332 | DL2 |
| DUR | 0003 | EVAL | 02A7 | FALL | 0326 | FL1 |
| FL2 | 036F | FREQ | 0004 | GETKEY | 0100 | GETRND |
| HIBYTE | 0360 | HILIM | 00B7 | HITONE | 0020 | INCR |
| INDX | 000B | KEY | 0218 | LDRND | 022F | LEDUPD |
| LIGHT | 033D | LOBYTE | 035C | LOLIM | 005A | LOSE |
| LOSEND | 031B | LOTONE | 00F0 | LTABLE | 001A | LTCC |
| LTMSK | 000E | LTSHT | 034D | NORST | 0258 | NXTUPD |
| OFFLD9 | 0280 | PORT1A | A001 | PORT1B | A000 | PORT3B |
| RANDOM | 0380 | RISE | 0300 | RND | 0014 | RND\$H |
| SCORE | 0002 | SCORLP | 02BC | SCOREB | 0023 | SCORTP |
| SPDPRM | 0050 | SPDUPD | 0269 | SPEEDS | 0005 | START |
| TICL | A004 | TEMP | 0000 | TEMP | 0364 | UPDATE |
| UPDTLP | 0247 | VALUES | 0011 | WAIT | 0294 | WIN |
| WINEND | 02EE | | | | | |
| END OF ASSEMBLY | | | | | | |

Fig. 7.9: Slot Machine Program (Continued)

- SCORTP is used as a temporary storage for the score gained or lost on each spin
- SCORE is the game score
- DUR and FREQ specify the usual constants for tone generation
- SPEEDS (3 locations) specify the revolution speeds for the three columns
- INDX (3 locations): delay counters for LED revolutions
- INCR (3 locations): pointers to the LED positions in each column used to fetch patterns out of tables
- LTMSK (3 locations): patterns indicating lit LEDs
- VALUES (3 locations): number of LEDs lit in each column
- RND (6 locations): scratch-pad for random number generator.

Program Implementation

The program consists of a main program and two main subroutines: DISPLY and EVAL. It also contains some utility subroutines: DELAY for a variable length delay, LIGHT to light the appropriate LED, TONE to generate a tone, and RANDOM to generate a random number.

The main program is stored at memory locations 200 and up. As usual, the three data-direction registers for Ports A and B of VIA#1 and for Port B of VIA#3 must be conditioned as outputs:

```
LDA #$FF
STA DDR1A
STA DDR1B
STA DDR3B
```

As in previous chapters, the counter register of timer 1 is used to provide an initial random number (a seed for the random number generator). This seed is stored at memory location RND + 1, where it will be used later by the random number generation subroutine:

```
LDA T1CL
STA RND + 1
```

On starting a new game, the initial score is set to 8. It is established:

```
START    LDA #8
          STA SCORE
```

and displayed:

```
TAY          Y must contain it
JSR LIGHT
```

The LIGHT subroutine is used to display the score by lighting up the LED corresponding to the contents of register Y. It will be described later.

The slot machine program is now ready to respond to the player. Any key may be pressed:

```
KEY      JSR GETKEY
```

As soon as a key has been pressed, the wheels must be spun:

```
JSR DISPLY
```

Once the wheels have stopped, the score must be evaluated and displayed with the accompanying sound:

```
JSR EVAL
```

If the final score is not "0," the process is restarted:

```
LDA SCORE
BNE KEY
```

and the user may spin the wheels again. Otherwise, if the score was "0," a new game is started:

```
BEQ START
```

This completes the body of the main program. It is quite simple because it has been structured with subroutines.

The Subroutines

The algorithms corresponding to the two main subroutines DISPLY and EVAL have been described in the previous section. Let us now consider their program implementation.

DISPLY Subroutine

Three essential subroutine parameters are LOLIM, HILIM, and SPDPRM. For example, lowering LOLIM will result in a longer spinning time for the LEDs. Various other effects can be obtained by varying these three parameters. One might be to include a win almost every time! Here LOLIM = 90, HILIM = 134, SPDPRM = 80.

Memory location INCR is used as a pointer to the current LED position. It will be used later to fetch the appropriate bit pattern from the table, and may have the value 0, 1, or 2 (pointing to LED positions 1, 2, or 3). The three pointers for the LEDs in each column are stored respectively at memory locations INCR, INCR + 1, and INCR + 2. They are initialized to 0:

```

DISPLY    LDA #0
          STA INCR
          STA INCR + 1
          STA INCR + 2
    
```

Note that in the previous examples (such as Figure 7.7), in order to simplify the explanations, we have used pointers X and Y to represent the values between 1 and 3. Here, X and Y will have values ranging between 0 and 2 to facilitate indexing. The wheel pointer is set to the right-most wheel:

```

LDRND    LDY #2
    
```

An initial random number is obtained with the RANDOM subroutine:

```

GETRND   JSR RANDOM
    
```

The number returned by the subroutine is compared with the acceptable low limit and the acceptable high limit. If it does not fit within the specified interval, it is rejected, and a new number is obtained until one is found which fits the required interval.

```

          CMP #HILIM    Too large?
          BCS GETRND    If so, get another
          CMP #LOLIM    Too small?
          BCC GETRND    If so, get another
    
```

The valid random number is then stored in the index location INDX and in the SPEEDS location for the current column. (See Figure 7.10.)

```

          STA INDX,Y
          STA SPEEDS,Y
    
```

The same process is carried out for column 1 and column 0:

```

          DEY
          BPL GETRND    Get next random #
    
```

Once all three columns have obtained their index and speed, a new iteration loop is started, using register X as a wheel counter:

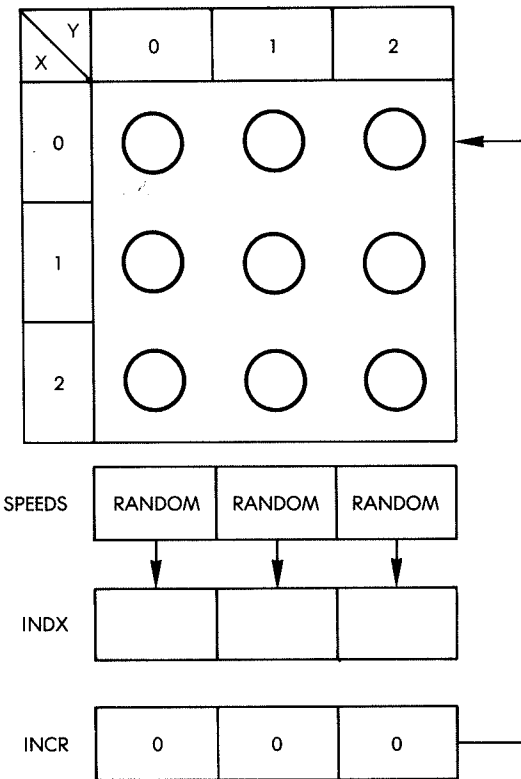

Fig. 7.10: Spinning the Wheels

```

UPDATE   LDX #2           Set counter for 3 iterations
    
```

The speed is tested for the value 0:

```

UPDTLP   LDY SPEEDS,X    Is speed (X) = 0?
          BEQ NXTUPD     If so, update next column
    
```

As long as the speed is not 0, the next LED in that column will have to be lit. The delay count is decremented:

```

          DEC INDX,X     Decrement loop, index (X)
    
```

If the delay has not decremented to 0, a branch occurs to NXTUPD which will be described below. Otherwise, if the delay counter INDX is decremented to 0, the next LED should be lit. The LED pointer is incremented with a possible wrap-around if it reaches the value 3:

| | | |
|-------|------------|--|
| | BNE NXTUPD | If loop index(X) < > 0, do next update |
| | LDY INCR,X | Inc pointer |
| | INY | |
| | CPY #3 | Pointer = 3? |
| | BNE NORST | If not, skip |
| | LDY #0 | Reset to 0 |
| NORST | STY INCR,X | Restore pointer(X) |

The new value of the LED pointer is stored back into INCR for the appropriate column. (Remember that within the UPDATE routine, X points at the column.) In order to light the appropriate LED, a bit pattern must be obtained from LTABLE. Note that LTABLE (and also SCORTB) is treated conceptually, as if it was a two-dimensional array, i.e., having rows and columns. However, both LTABLE and SCORTB appear in memory as a contiguous series of numbers. Thus, in order to obtain the address of a particular element, the row number must be multiplied by the number of columns and then added to the column number.

The table will be accessed using the indexed addressing mode, with register Y used as the index register. In order to access the table, X must first be multiplied by 3, then the value of INCR (i.e., the LED pointer) must be added to it.

Multiplication by 3 is accomplished through a left shift followed by an addition, since a left shift is equivalent to multiplication by 2:

| | | |
|--|----------|-----------------|
| | STX TEMP | Multiply X by 3 |
| | TXA | |
| | ASL A | Left shift |
| | CLC | |
| | ADC TEMP | Plus one |

The value of INCR is added, and the total is transferred into register Y so that indexed addressing may be used. Finally, the entry may be retrieved from LTABLE:

```
ADC INCR,X
TAY
LDA LTABLE,Y    Get pattern for LED
```

Once the pattern has been obtained, it is stored in one of three memory locations at address LTMSK and following. The pattern is stored at the memory location corresponding to the column currently being updated, where the LED has "moved." The lights will be turned on only after the complete pattern for all three columns has been implemented. As a result of the LED having moved one position within that column, the speed constant must be incremented:

```
STA LTMSK,X
SPDUPD    LDY SPEEDS,X
          INY
          STY SPEEDS,X
```

The index is set so that it is equal to the new speed:

```
STY INDX,X
```

Note that special handling will now be necessary for LED #9. The pattern to be displayed on the first eight LEDs was stored in the LTABLE. The fact that LED #9 must be lit is easily recognized by the fact that the pattern for column #3 shows all zeroes; since one LED must be lit at all times within that column, it implies that LED #9 will be lit:

```
LEDUPD    LDA #0
          STA PORT1B    Reset LED 9
```

Next, the pattern for the third column is obtained from the location where it had been saved at LTMSK + 2. It is tested for the value of 0:

```
LDA LTMSK + 2
BNE OFFLD9
```

If this pattern is 0, then LED #9 must be turned on:

```
LDA #01
```

STA PORT1B

Otherwise, a branch occurs to location OFFLD9, and the remaining LEDs will be turned on. The pattern contained in the accumulator which was obtained from LTMSK + 2, is successively OR'ed with the patterns for the second and first columns:

```

LDA #0
OFFLD9  ORA LTMSK
        ORA LTMSK + 1

```

At this point, A contains the final pattern which must be sent out in the output port to turn on the required LED pattern. This is exactly what happens:

STA PORT1A

At the same time, the speaker is toggled:

```

LDA PORT3B
EOR #$FF
STA PORT3B

```

It is important to understand that even though only the LED for one of the three columns has been moved, it is necessary to simultaneously turn on LEDs in all of the columns or the first and second columns would go blank!

Once the third column has been taken care of, the next one must be examined. The column pointer X is therefore decremented, and the process is continued:

```

NDTUPD  DEX
        BPL UPDTLP    If X >= 0 do next update

```

Once the second and the first columns have been handled, a delay is implemented to avoid flashing the LEDs too fast. This delay is controlled by the speed parameter SPDPRM:

```

WAIT    LDY #SPDPRM
        DEY
        BNE WAIT

```

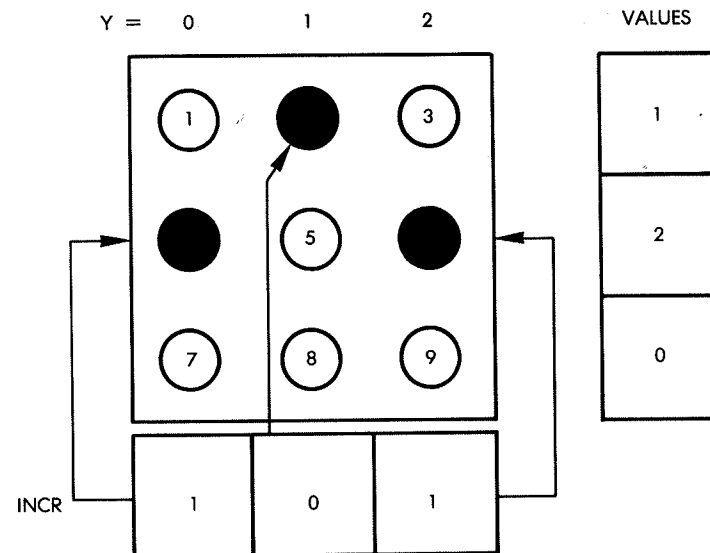

Fig. 7.11: Evaluating the End of A Spin

Once this complete cycle has been executed, the speed location for each column is checked for the value 0. If all columns are 0, the spin is finished:

```

LDA SPEEDS
ORA SPEEDS + 1
ORA SPEEDS + 2
BNE UPDATE

```

Otherwise, a branch occurs at the location UPDATE. If all LEDs have stopped, a pause must be generated so that the user may see the pattern:

```

LDA #$FF
STA DUR
JSR DELAY

```

and exit occurs:

```

RTS

```

Exercise 7-2: Note that the contents of the three SPEEDS locations have been OR'ed to test for three zeroes. Would it have been equivalent to add them together?

EVAL Subroutine

This subroutine is the user output interface. It computes the score achieved by the player and generates the visual and audio effects. The constants for frequencies for the high tone generated by a win situation and the low tone generated by a lose situation are specified at the beginning of this subroutine:

```
HITONE = $20
LOTONE = $F0
```

The method used to compute the number of LEDs lit per row has been discussed and shown in Figure 7.7. The number of LEDs lit for each row is initially reset to 0:

```
EVAL      LDA #0
           STA VALUES
           STA VALUES + 1
           STA VALUES + 2
```

The temporary score is also set to 0:

```
STA SCORTP
```

Index register Y will be used as a column pointer, and the number of LEDs lit in each row will be computed. The number of the LED lit for the current column is obtained by reading the appropriate INCR entry. See the example in Figure 7.11. The value contained in each of the three locations reserved for INCR is a row number. This row number is stored in register X, and is used as an index to increment the appropriate value in the VALUES table. Notice how this is accomplished in just two instructions, by cleverly using the indexed addressing feature of the 6502 twice:

```
CNTLP      LDY #2           3 iterations
           LDX INCR,Y
           INC VALUES,X
```

Once this is done for column 2, the process is repeated for columns 1 and 0:

```
DEY
BPL CNTLP
```

Now, another iteration will be performed to convert the final numbers entered in the VALUES table into the actual scores as per the specifications of the score table, SCORTB. Index register X is used as a row-pointer for VALUES and SCORTB.

```
LDX #2
```

Since the SCORTB table has four one-byte entries per row level, in order to access the correct byte within the table the row number must first be multiplied by 4, then the corresponding "value" (number of LEDs lit) for that row must be added to it. This provides the correct displacement. The multiplication by 4 is implemented by two successive left shifts:

```
SCORLP     TXA
           ASL A
           ASL A
```

The number presently contained in the accumulator is equal to 4 times the value contained in X, i.e., 4 times the value of the row-pointer. To obtain the final offset within the SCORTB table, we must add to that the number of LEDs lit for that row, i.e., the number contained in the VALUES tables. This number is retrieved, as usual, by performing an indexed addressing operation:

```
CLC
ADC VALUES,X  Column address in array
```

This results in the correct final offset for accessing SCORTB.

The indexed access of the SCORTB table can now be performed. Index register Y is used for that purpose, and the contents of the accumulator are transferred to it:

```
TAY
```

The access is performed:

```
LDA SCORTB,Y    Get score for this spin
```

The correct score for the number of LEDs lit within the row pointed to by index register X is now contained in the accumulator. The partial score obtained for the current row is added to the running total for all rows:

```
CLC
ADC SCORTP      Total the scores
STA SCORTP      Save
```

The row number is then decremented so that the next row can be examined. If X decrements from the value 0, i.e., becomes negative, we are done; otherwise, we loop:

```
DEX
BPL SCORLP
```

At this point, a total score has been obtained for the current spin. Either a win or a lose must be signaled to the player, both visually and audibly. In anticipation of activating the speaker, the memory location DUR is set to the correct tone duration:

```
LDA #$60
STA DUR
```

The score is then examined: if 0, a branch occurs to the LOSE routine:

```
LDA SCORTP
BEQ LOSE
```

Otherwise, it is a win. Let us examine these two routines.

WIN Routine

The final score for the user (for all spins so far) is contained in memory location SCORE. This memory location will be incremented one point at a time and checked every time against the maximum value 16. Let us do it:

```
WIN          INC SCORE
            LDY SCORE
            CPY #16
```

If the maximum value of 16 has been reached, it is the end of the game and a branch occurs to location WINEND:

```
BEQ WINEND
```

Otherwise, the score display must be updated and a beep must be sounded:

```
JSR LIGHT
```

The LIGHT routine will be described below. It displays the score to the player. Next, a beep must be sounded.

```
LDA #HITONE
JSR TONE
```

The TONE routine will be described later.
A delay is then implemented:

```
JSR DELAY
```

then the score for that spin is decremented:

```
DEC SCORTP
```

and checked against the value 0. If it is 0, the scoring operation is complete; otherwise, the loop is reentered:

```
BNE WIN
RTS
```

WINEND Routine

This routine is entered whenever a total score of 16 has been reached. It is the end of the game. All LEDs are turned on simultaneously, and a siren sound with rising frequencies is activated. Finally, a restart of the game occurs.

All LEDs are turned on by loading the appropriate pattern into Port 1A and Port 1B:

```
LDA #$FF
STA PORT1A    Turn on all LEDs
STA PORT1B
```

Variables are reinitialized: the total score becomes 0, which signals to the main program that a new game must be started, the DUR memory location is set to 4 to control the duration of time for which the beeps will be sounded, and the frequency parameter is set to "FF" at location TEMP:

```
STA TEMP      Freq. parameter
LDA #0
STA SCORE     Clear for restart
LDA #4
STA DUR       Beep duration
```

The TONE subroutine is used to generate a beep:

```
RISE          LDA TEMP      Get frequency
              JSR TONE      Generate beep
```

The beep frequency constant is then decremented, and the next beep is sounded at a slightly higher pitch:

```
DEC TEMP
BNE RISE
```

Whenever the frequency constant has been decremented to 0, the siren is complete and the routine exits:

```
RTS
```

LOSE Routine

Now let us examine what happens in the case of a lose situation. The events are essentially symmetrical to those that have been described for the win.

In the case of a loss, the score needs to be updated only once. It is decremented by 1:

```
LOSE          DEC SCORE
```

The lowered score is displayed to the user:

```
LDY SCORE
JSR LIGHT
```

An audible tone is generated:

```
LDA #LOTONE
JSR TONE
```

The final value of the score is checked to see whether a "0" score has been reached. If so, the game is over; otherwise, the next spin is started:

```
LDY SCORE
BEQ LOSEND
RTS
```

Let us look at what happens when a "0" score is reached (LOSEND). A siren of decreasing frequencies will be generated. All LEDs will go blank on the board:

```
LOSEND        LDA #0
              STA TEMP
              STA PORT1A    Clear LED #1
```

The beep duration for each frequency is set to a value of 4, stored at memory location DUR:

```
LDA #4
STA DUR
```

The beep for the correct frequency is then generated:

```
FALL          LDA TEMP
              JSR TONE      Play beep
```

Next, the frequency constant is increased by 1, and the process is restarted until the TMP register overflows.

```

INC TEMP      Next tone will be lower
BNE FALL
RTS

```

This completes our description of the main program. Let us now examine the four subroutines that are used. They are: DELAY, LIGHT, TONE, and RANDOM.

DELAY Subroutine

This subroutine implements a delay; the duration of the delay is set by the contents of memory location DUR. The resulting delay length will be equal to $(2046 \times \text{DUR} + 10)$ microseconds. The delay is implemented using a traditional two-level, nested loop structure. The inner-loop delay is controlled by index register X, while the outer-loop delay is controlled by index register Y, which is initialized from the contents of memory location DUR. Y is therefore initialized:

```

DELAY      LDY DUR

```

The inner loop delay is then implemented:

```

DL1      LDX #$FF
DL2      BNE *+2      Waste time
          DEX          Inner loop counter
          BNE DL2     Inner loop

```

And, finally, the outer loop is implemented:

```

          DEY
          BNE DL1
          RTS

```

Exercise 7-3: *Verify the exact duration of the delay implemented by the DELAY subroutine.*

LIGHT Subroutine

This subroutine lights the LED corresponding to the number contained in register Y. Remember that the fifteen LEDs on the Games

Board are numbered externally from 1 to 15 but are connected to bits 0 to 7 of Port 1A and 0 to 7 of Port 1B. Thus, if a score of 1 must be displayed, bit 0 of Port 1A must be turned on. Generally, bit N of Port 1A must be turned on when N is equal to the score minus one. However, there is one exception. To see this, refer to Figure 1.4 showing the LED connections. Notice that bit 6 of Port 1B is not connected to any LEDs. Whenever a score of fifteen must be displayed, bit 7 of Port 1B must be turned on. This exception will be handled in the routine by simply not decrementing the score when it adds up to fifteen.

The correct pattern for lighting the appropriate LED will be created by shifting a "1" into the accumulator at the correct position. Other methods will be suggested in the exercise below. Let us first initialize:

```

LIGHT     LDA #0
          STA TEMP
          STA PORT1A
          STA PORT1B

```

We must first look at the situation where the score contained in Y is 15 and where we do nothing (no shift):

```

          CPY #15      Code for uncorrected bit?
          BEQ *+3      If so, no change

```

For any other score, it is first decremented, then the shift is performed:

```

          DEY          Decrement to internal code
          SEC          Set bit to be shifted
LTSHFT    ROL A

```

The contents of the accumulator were zeroed in the first instruction of this subroutine. The carry is set to the value 1, then shifted into the right-most position of A. (See Figure 7.12.) This process will be repeated as many times as necessary. Since we must count from 1 to 14, or 0 to 13, an overflow will occur whenever the "1" that is rotated in the accumulator "falls off" the left end. As long as this does not happen, the shifting process continues, and a branch to location LTCC is implemented:

```

          BCC LTCC

```

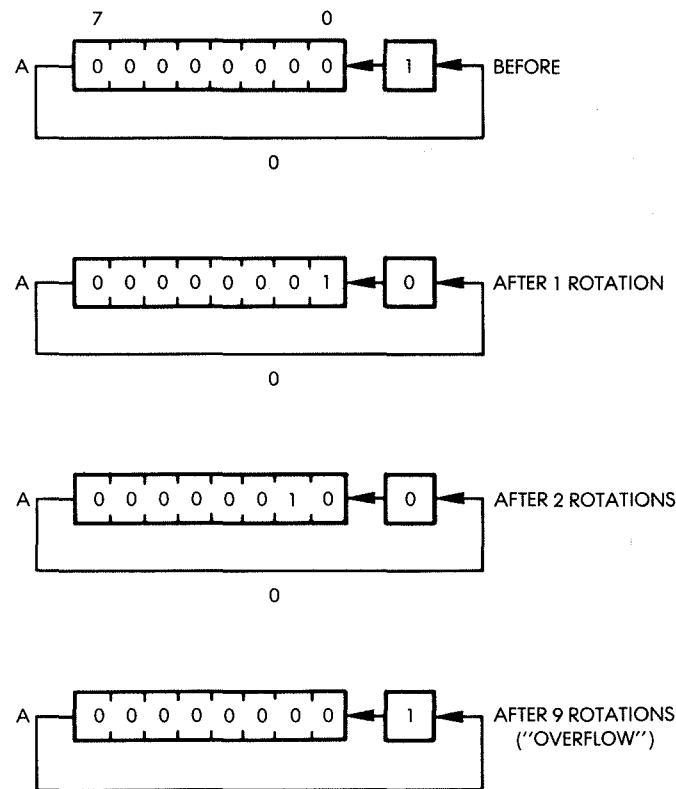

Fig. 7.12: Creating the LED Pattern

However, if the "1" bit does fall off the left end of the accumulator, the value "FF" is loaded at memory location TEMP to signal this occurrence. Remember that the value was cleared in the second instruction of the LIGHT subroutine.

```
LDX #$FF
STX TEMP
```

The "1" bit is then moved from the carry into the right-most position of the accumulator. Later, the value contained in memory location TEMP will be checked, and this will determine whether the pattern contained in the accumulator is to be sent to Port 1A or to Port 1B.

The shifting process continues. The counter is decremented, and, if it reaches the value "0," we are done; otherwise, the process is repeated:

```
LTCC      ROL A
          DEY
          BPL LTSHFT
```

Once the process is completed, the value of memory location TEMP is examined. If this value is "0," it indicates that no overflow has occurred and Port 1A must be used. If this value is not "0," i.e., it is "FF," then Port 1B must be used:

```
LDX TEMP      Get overflow flag
BNE HIBYTE
LOBYTE        STA PORT1A    A sent to low LEDs
              RTS          Return
HIBYTE        STA PORT1B    A sent to high LEDs
              RTS
```

TONE Subroutine

This subroutine generates a beep. The frequency of the beep is determined by the contents of the accumulator on entry; the duration of the beep is set by the contents of the memory location DUR. This has already been described in Chapter 2.

RANDOM Subroutine

This is a simple random number generator. The subroutine has already been described in Chapter 3.

Exercise 7-4: Suggest another way to generate the correct LED pattern in the accumulator, without using a sequence of rotations.

Game Variations

The three rows of LEDs supplied on the Games Board may be interpreted in a way that is different from the one used at the beginning of this chapter. Row 1 could be interpreted as, say, cherries. Row 2 could be interpreted as stars, and row 3 could be interpreted as oranges. Thus, an LED lit in row 1 at the end of a spin shows a cherry, while

two LEDs in row 3 show two oranges. The resulting combination is one cherry and two oranges. The scoring table used in this program can be altered to score a different number of points for each combination, depending upon the number of cherries, oranges, or stars present at the end of the spin. It becomes simply a matter of modifying the values entered into the scoring table. When new values are entered into the scoring table a completely different scoring result will be implemented. No other alterations to the program will be needed.

SUMMARY

This program, although simple in appearance, is relatively complex and can lead to many different games, depending upon the evaluation formula used once the lights stop. For clarity, it has been organized into separate routines that can be studied individually.

8

ECHO

THE RULES

The object of this game is to recognize and duplicate a sequence of lights and sounds which are generated by the computer. Several variations of this game, such as "Simon" and "Follow Me" (manufacturer trademarks*), are sold by toy manufacturers. In this version, the player must specify, before starting the game, the length of the sequence to be recognized. The player indicates his or her length preference by pressing the appropriate key between 1 and 9. At this point the computer generates a random sequence of the desired length. It may then be heard and seen by pressing any of the alphabetic keys (A through F).

When one of the alphabetic keys is pressed, the sequence generated by the program is displayed on the corresponding LEDs (labeled 1 through 9) on the Games Board, while it is simultaneously played through the loudspeaker as a sequence of notes. While this is happening, the player should pay close attention to the sounds and/or lights, and then enter the sequence of numbers corresponding to the sequence he or she has identified. Every time that the player presses a correct key, the corresponding LED on the Games Board lights up, indicating a success. Every time a mistake is made, a low-pitched tone is heard.

At the end of the game, if the player has guessed successfully, all LEDs on the board will light up and a rising scale (succession of notes) is played. If the player has failed to guess correctly, a single LED will light up on the Games Board indicating the number of errors made, and a descending scale will be played.

If the player guessed the series correctly, the game will be restarted. Otherwise, the number of errors will be cleared and the player will be given another chance to guess the series.

*"Follow Me" is a trademark of Atari, Inc., "Simon" is a trademark of Milton Bradley Co.

At any time during a game, the player may press one of the alphabetic keys that will allow him or her to hear the sequence again. All previous guesses are then erased, and the player starts guessing again from the beginning.

Two LEDs on the bottom row of the LED matrix are used to communicate with the player:

LED 10 (the left-most LED) indicates "computer ready — enter the length of the sequence desired."

LED 11 lights up immediately after the player has specified the length of the sequence. It will remain lit throughout the game and it means that you should "enter your guess."

At this point, the player has three options:

1. To press a key corresponding to the number in the sequence that he or she is attempting to recognize.
2. To press key 0. This will result in restarting the game.
3. To press keys A through F. This will cause the computer to play the sequence again, and will restart the guessing sequence.

Variations

The program provides a good test for your musical abilities. It is suggested that you start each new game by just listening to the sequence as it is played on the loudspeaker, without looking at the LEDs. This is because the LEDs on the Games Board are numbered, and it is fairly easy to remember the light sequence simply by memorizing the numbers. This would be too simple. The way you should play it is to start with a one-note sequence. If you are successful, continue with a two-note sequence, and then with a three-note sequence. Match your skills with other players. The player able to recognize the longest sequence is the winner. Note that some players are capable of recognizing a nine-note sequence fairly easily.

After a certain number of notes are played (e.g., when more than five notes are played), in order to facilitate the guessing you may allow the player to look at the LEDs on the Games Board. Another approach might be to allow the player to press one of the alphabetic keys at any time in order to listen to the sequence again. However, you may want to require that the player pay a penalty for doing this. This could be achieved by requiring that the player recognize a second sequence of the same length before trying a longer one. This means that if, for example, a player attempts to recognize a five-note sequence but becomes nervous after making a mistake and forgets the sequence,

that player will be allowed to press one of the alphabetic keys and hear the sequence again. However, if the player is successful on the second attempt, he or she must then recognize another five-note sequence before proceeding to a six-note one.

You can be even tougher and specify that any player is allowed a replay of the stored pattern a maximum of two, three, or five times per game. In other words, throughout the games a player may replay the sequence he or she is attempting to guess by pressing one of the alphabetic keys, but this resource may be used no more than n times.

An ESP Tester

Another variation of this game is to attempt to recognize the sequence without listening to it or seeing it! Clearly, in such a case you can rely only on your ESP (Extra Sensory Perception) powers to facilitate guessing. In order to determine whether you have ESP or not, set the length of the initial sequence to "1." Then, hit the key in an attempt to guess the note selected by the program. Try this a number of times. If you do not have ESP your results should be random. Statistically, you should win one out of nine times which is only one-ninth of the time, or 11.11% of the time. Note that this percentage is valid only for a large number of guesses.

If you win more than 11% of the time, you may have ESP! If your score is higher than 50%, you should definitely run for political office or immediately apply for a top management position in business. If your score is less than 11%, you have "negative ESP" and you should consider looking both ways before crossing the street.

The following is an exercise for readers who have a background in statistics.

Exercise 8-1: *Compute the statistical probability of guessing a correct two-number sequence, and a correct four-number sequence.*

A TYPICAL GAME

The program starts at location 200. As usual, LED 10 lights up as shown in Figure 8.1. We specify a series of length two by pushing key "2" on the keyboard. The LED display as it appears in Figure 8.2, means "enter your guess."

We want to hear the tunes so we push key "F." In response, LEDs 5 and 2 light up briefly on the Games Board and corresponding tones

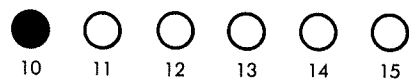

Fig. 8.1: Specify Length of Sequence to Duplicate

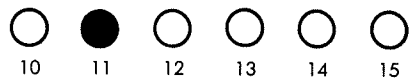

Fig. 8.2: Enter Your Guess

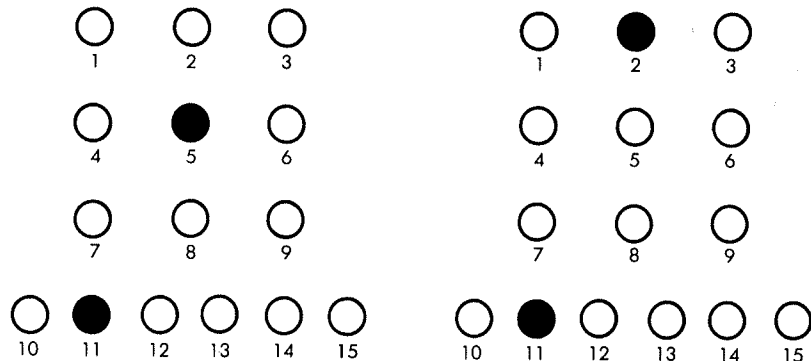

Fig. 8.3: Follow Me

are heard through the speaker. This is illustrated in Figure 8.3. We must now enter the sequence we have recognized. We push "5" on the keyboard. In response, LED 11 goes blank and LED 5 lights up briefly. Simultaneously, the corresponding note is played through the speaker. It is a successful guess!

Next, we press key "2." LED 2 lights up, and the speaker produces the matching tone indicating that our second guess has also been successful. A moment later, all LEDs on the board light up to congratulate us and the rising scale is sounded. It is a sequence of notes of increasing frequencies meant to confirm that we have guessed suc-

cessfully. The game is then restarted, and LED 10 lights up, as shown in Figure 8.1.

Let us now follow a losing sequence: LED 10 is lit at the beginning of the game, as in Figure 8.1. This time we press key "1" in order to specify a one-note sequence. LED 11 lights up, as shown in Figure 8.2. We press key "F," and the note is played on the speaker. (We do not look at the Games Board to see which LED lights up, as that would be too easy.) We press key "3." A "lose" sound is heard, and LED 1 lights up indicating that one mistake has been made. A decreasing scale is then played (notes of decreasing frequencies) to confirm to the unfortunate player that he or she has guessed the sequence incorrectly. The game is then continued with the same sequence and length, i.e., the situation is once again the one indicated in Figure 8.2.

If at this point the player wants to change the length of the sequence, or enter a new sequence, he or she must explicitly restart the game by pressing key 0. After pressing key 0, the situation will be the one indicated in Figure 8.1, where the length of the sequence can be specified again.

THE ALGORITHM

The flowchart for this program is shown in Figure 8.4. Let us examine it, step-by-step:

1. The program tells the player to select a sequence length by lighting LED 10 on the Games Board.
2. The sequence length is read from the keyboard. (Keys 0 and A-F are ignored at this point.)
3. The two main variables are initialized to "0," i.e., the number of guesses and the number of errors are cleared.
4. A sequence table of the appropriate length must then be generated using random numbers whose values are between 1 and 9.
5. Next, LED 11 is lit, and the player's keystroke is read.
6. If it is "0," the game is restarted. Otherwise, we proceed.
7. If the keystroke value is greater than or equal to 10, it is an alphabetic character and we branch off to the right part of the flowchart into steps 8 and 9. The recorded sequence is displayed to the player, all variables are reinitialized to 0, and the guessing process is restarted. If the keystroke was a number between 1 and 9, it must be matched against the stored value. We go to 10 on the flowchart.

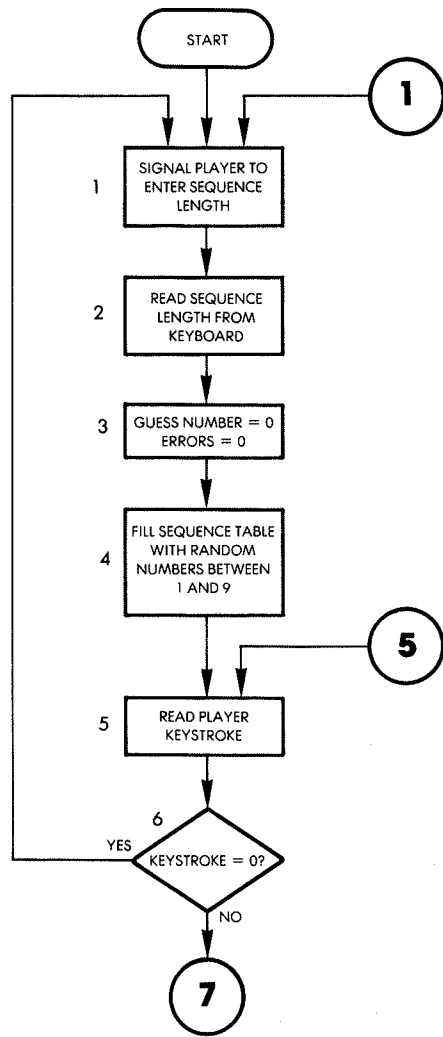

Fig. 8.4: Echo Flowchart

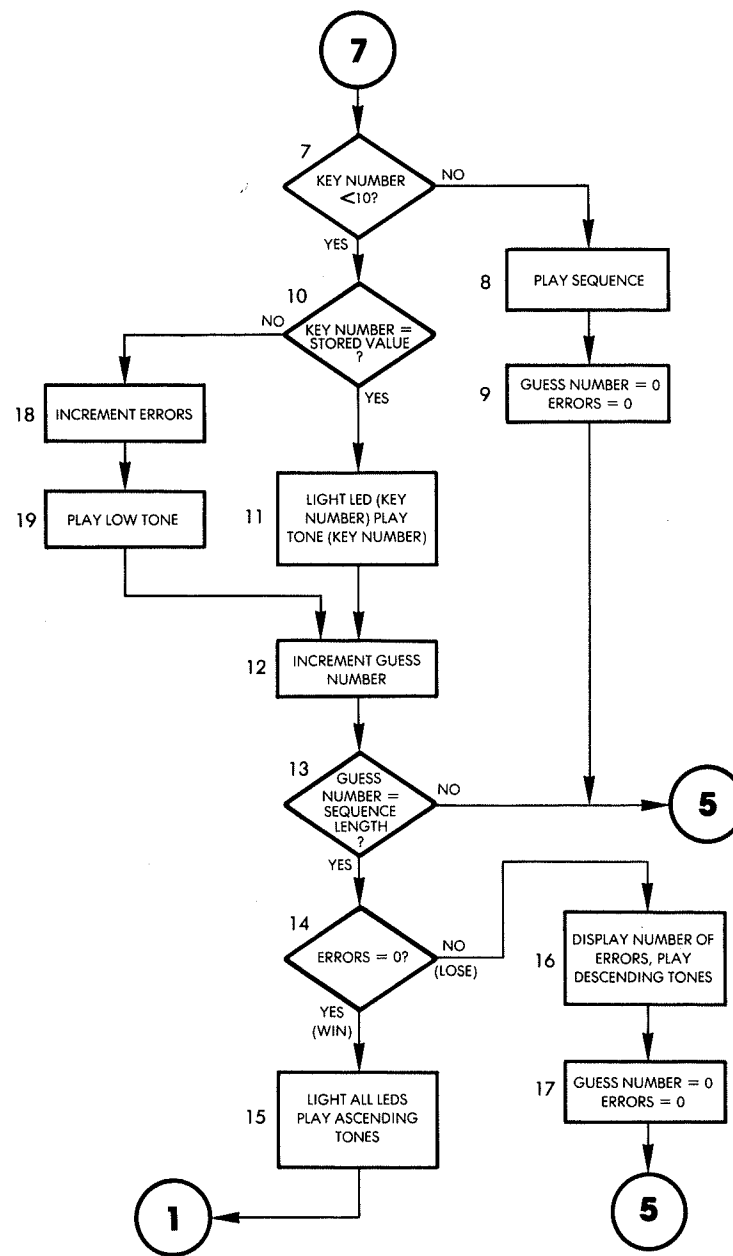

Fig. 8.4: Echo Flowchart (Continued)

10. If the guess was correct, we branch right on the flowchart to step 11.
 11. Since the key pressed matches the value stored in memory, the corresponding LED on the Games Board is lit, and the tone corresponding to the key that has been pressed is played.
 12. The guessed number is incremented, and then it is compared to the maximum length of the sequence to be guessed.
 13. A check is made to see if the maximum length of the sequence has been reached. If it has not, a branch occurs back to step 5 on the flowchart, and the next keystroke is obtained. If the maximum length of the sequence has been reached, we proceed down the flowchart to the box labeled 14.
 14. The total number of errors made by the player is checked. The variable ERRORS is tested against the value "0." If it is "0" it is a winning situation and a branch occurs to box 15.
 15. All LEDs on the board are lit, a sequence of ascending tones is played, and a branch occurs back to the beginning of the game.
- Let us now go back to box 14. If the number of errors was greater than zero, this is a "lose" situation and a branch occurs to box 16.
16. The number of errors is displayed, and a sequence of descending tones is played.
 17. All variables are reset to 0, and a branch occurs to box 5, giving the player another chance to guess the series.

Now we shall turn our attention back to box 10 on the flowchart, where the value of the key was being tested against the stored value. We will assume this time that the guess was wrong, and branch to the left of box 10.

18. The number of errors made by the player is incremented by one.
19. A low tone is played to indicate the losing situation. The program then branches back to box 12 and proceeds as before.

THE PROGRAM

The complete program appears in Figure 5.1. The program uses two tables, and several variables. The two tables are NOTAB used to specify the note frequencies, and DURTAB used to specify the note durations. Both of these tables were introduced in Chapter 2, and will not be described here. Essentially, they provide the delay constants required to implement a note of the appropriate frequency and to play it for the appropriate length of time. Note that it is possible to modify

| LINE | LOC | CODE | LINE |
|------|------|----------|---|
| 0002 | 0000 | | ; 'ECHO' |
| 0003 | 0000 | | ;PATTERN/TONE RECALL AND ESP TEST PROGRAM. |
| 0004 | 0000 | | ;THE USER GUESSES A PATTERN OF LIT LEDS AND |
| 0005 | 0000 | | ;THEIR ASSOCIATED TONES. THE TONE/LIGHT |
| 0006 | 0000 | | ;COMBINATION CAN BE PLAYED, SO THAT THE USER |
| 0007 | 0000 | | ;MUST REMEMBER IT AND REENTER IT CORRECTLY. |
| 0008 | 0000 | | ; OPERATING THE PROGRAM: |
| 0009 | 0000 | | ;THE STARTING ADDRESS IS \$200 |
| 0010 | 0000 | | ;THE BOTTOM ROW OF LEDS IS AN INDICATOR |
| 0011 | 0000 | | ;FOR PROGRAM STATUS: THE LEFTMOST |
| 0012 | 0000 | | ;ONE (#10) INDICATES THAT THE PROGRAM |
| 0013 | 0000 | | ;IS EXPECTING THE USER TO INPUT THE LENGTH |
| 0014 | 0000 | | ;OF THE SEQUENCE TO BE GUESSED. |
| 0015 | 0000 | | ;THE LED SECOND FROM THE LEFT (#11) INDICATES |
| 0016 | 0000 | | ;THAT THE PROGRAM EXPECTS EITHER A GUESS (1-9), |
| 0017 | 0000 | | ;THE COMMAND TO RESTART THE GAME (0), OR |
| 0018 | 0000 | | ;THE COMMAND TO PLAY THE SEQUENCE (A-F). |
| 0019 | 0000 | | ;THE KEYS 1-9 ARE ASSOCIATED WITH THE |
| 0020 | 0000 | | ;LEDS 1-9. |
| 0021 | 0000 | | ;LOOKING AT THE SEQUENCE WHILE IN THE MIDDLE |
| 0022 | 0000 | | ;OF GUESSING IT WILL ERASE ALL PREVIOUS |
| 0023 | 0000 | | ;GUESSES (RESET GESNO AND ERRS TO 0). |
| 0024 | 0000 | | ;AFTER A WIN, THE PROGRAM RESTARTS. |
| 0025 | 0000 | | ; |
| 0026 | 0000 | | ;LINKAGES: |
| 0027 | 0000 | | GETKEY = #100 |
| 0028 | 0000 | | ; |
| 0029 | 0000 | | ;VARIABLE STORAGES: |
| 0030 | 0000 | | DIGITS = #00 ;NUMBER OF DIGITS IN SEQUENCE |
| 0031 | 0000 | | GESNO = #01 ;NUMBER OF CURRENT GUESS. |
| 0032 | 0000 | | ;(WHERE THE USER IS IN THE SERIES) |
| 0033 | 0000 | | ERRS = #02 ;NUMBER OF ERRORS MADE IN |
| 0034 | 0000 | | ;GUESSING CURRENT SEQUENCE. |
| 0035 | 0000 | | DUR = #03 ;TEMP STORAGE FOR NOTE DURATION. |
| 0036 | 0000 | | FREQ = #04 ;TEMP STORAGE FOR NOTE FREQUENCY. |
| 0037 | 0000 | | TEMP = #05 ;TEMPORARY STORAGE FOR X REG. |
| 0038 | 0000 | | TABLE = #06 ;STORAGE FOR SEQUENCE |
| 0039 | 0000 | | RND = #0F ;SCRATCHPAD FOR RANDOM # GEN. |
| 0040 | 0000 | | ;4522 VIA #1 ADDRESSES: |
| 0041 | 0000 | | PORT1A = \$A001 |
| 0042 | 0000 | | DDR1A = \$A003 |
| 0043 | 0000 | | PORT1B = \$A000 |
| 0044 | 0000 | | DDR1B = \$A002 |
| 0045 | 0000 | | TICL = \$A004 |
| 0046 | 0000 | | ;4522 VIA #3 ADDRESSES |
| 0047 | 0000 | | PORT3B = \$AC00 |
| 0048 | 0000 | | DDR3B = \$AC02 |
| 0049 | 0000 | | ; |
| 0050 | 0000 | | * = \$200 |
| 0051 | 0200 | | ; |
| 0052 | 0200 | A9 FF | START LDA #\$FF ;SET UP DATA DIRECTION REGISTERS. |
| 0053 | 0202 | 8D 03 A0 | STA DDR1A |
| 0054 | 0205 | 8D 02 A0 | STA DDR1B |
| 0055 | 0208 | 8D 02 AC | STA DDR3B |
| 0056 | 020E | A9 00 | LDA #0 ;CLEAR VARIABLE STORAGES |
| 0057 | 020D | 8D 01 A0 | STA PORT1A ;...AND LEDS |
| 0058 | 0210 | 85 02 | STA ERRS |
| 0059 | 0212 | 85 01 | STA GESNO |
| 0060 | 0214 | AD 04 A0 | LDA TICL ;GET SEED FOR RND # GEN. |
| 0061 | 0217 | 85 10 | STA RND+1 ;AND STORE IN RND SCRATCH. |
| 0062 | 0219 | 85 13 | STA RND+4 |
| 0063 | 021B | A9 02 | LDA #2010 ;TURN LED #10 ON TO INDICATE |
| 0064 | 021D | 8D 00 A0 | STA PORT1B ;NEED FOR LENGTH INPUT. |
| 0065 | 0220 | 20 00 01 | DIGKEY JSR GETKEY ;GET LENGTH OF SERIES. |
| 0066 | 0223 | C9 00 | CMF #0 ;IS IT 0 ? |
| 0067 | 0225 | F0 F9 | BEQ DIGKEY ;IF YES, GET ANOTHER. |
| 0068 | 0227 | C9 0A | CMF #10 ;LENGTH GREATER THAN 9? |
| 0069 | 0229 | 10 F5 | BPL DIGKEY ;IF YES, GET ANOTHER. |
| 0070 | 022B | 85 00 | STA DIGITS ;SAVE VALID LENGTH |

Fig. 8.5: Echo Program

```

0071 022D AA TAX #USE LENGTH-J AS INDEX FOR FILLING...
0072 022E CA DEX #..SERIES W/RANDOM VALUES.
0073 022F 86 05 FILL STX TEMP #SAVE X FROM 'RANDOM'
0074 0231 20 E7 02 JSR RANDOM
0075 0234 A6 05 LDX TEMP #RESTORE X
0076 0236 F8 SED #DO A DEIMAL ADJUST
0077 0237 18 CLC
0078 0238 69 00 ADC #0
0079 023A D8 CLD
0080 023B 29 0F AND #*0F #REMOVE UPPER NYBBLE SO
0081 023D #NUMBER IS <10
0082 023D F0 F0 BEQ FILL #* CAN'T BE ZERO.
0083 023F 95 04 STA TABLE,X #STORE # IN TABLE
0084 0241 CA DEX #DECREMENT FOR NEXT
0085 0242 10 EB BPL FILL #LOOP IF NOT DONE
0086 0244 A9 00 KEY LDA #0 #CLEAR LEDS
0087 0246 8D 01 A0 STA PORT1A
0088 0249 A9 04 LDA #%0100 #TURN INPUT INDICATOR ON.
0089 024B 8D 00 A0 STA PORT1B
0090 024E 20 00 01 JSR GETKEY #GET GUESS OR PLAY CMD.
0091 0251 C9 00 CMP #0 #IS IT 0 ?
0092 0253 F0 AB STRTJP BEQ START #IF YES, RESTART.
0093 0255 C9 0A CMP #10 #NUMBER < 10 ?
0094 0257 30 22 BMI EVAL #IF YES, EVALUATE GUESS.
0095 0259 ;
0096 0259 #ROUTINE TO DISPLAY SERIES TO BE GUESSED BY
0097 0259 #LIGHTING LEDS AND PLAYING TONES IN SEQUENCE.
0098 0259 ;
0099 0259 A2 00 SHOW LDX #0
0100 025B 86 01 STX GESNO #CLEAR ALL CURRENT GUESSES.
0101 025B 86 02 STX ERRS #CLEAR CURRENT ERRORS.
0102 025F 85 06 SHOWLP LDA TABLE,X #GET XTH ENTRY IN SERIES TABLE.
0103 0261 86 05 STX TEMP #SAVE X
0104 0263 20 CF 02 JSR LIGHT #LIGHT LED*(TABLE(X))
0105 0266 20 FA 02 JSR PLAY #PLAY TONE*(TABLE(X))
0106 0269 A0 FF LDY #*FF #SET LOOP CNTR. FOR DELAY
0107 026B 64 03 DELAY ROR DUR #WASTE TIME
0108 026D 26 03 ROL DUR
0109 026F 88 DEY #COUNT DOWN...
0110 0270 D0 F9 BNE DELAY #IF NOT DONE, LOOP AGAIN.
0111 0272 A6 05 LDX TEMP #RESTORE X
0112 0274 EB INX #INCREMENT INDEX TO SHOW NEXT
0113 0275 E4 00 CPX DIGITS #ALL DIGITS SHOWN?
0114 0277 D0 E6 BNE SHOWLP #IF NOT, SHOW NEXT.
0115 0279 F0 C9 BEQ KEY #DONE: GET NEXT INPUT.
0116 027B ;
0117 027B #ROUTINE TO EVALUATE GUESSES OF PLAYER.
0118 027B ;
0119 027B A6 01 EVAL LDX GESNO #GET NUMBER OF GUESS.
0120 027D D5 04 CMP TABLE,X #GUESS = CORRESPONDING DIGIT?
0121 027F F0 0D BEQ CORECT #IF YES, SHOW PLAYER.
0122 0281 E6 02 WRONG INC ERRS #GUESS WRONG, ANOTHER ERROR.
0123 0283 A9 80 LDA #*80 #DURATION FOR LOW TONE TO INDICATE
0124 0285 85 03 STA DUR #BAD GUESS.
0125 0287 A9 FF LDA #*FF #FREQUENCY CONSTANT
0126 0289 20 04 03 JSR PLYTON #PLAY IT
0127 028C F0 06 BEQ ENDCHK #CHECK FOR ENDGAME
0128 028E 20 CF 02 CORECT JSR LIGHT #VALIDATE CORRECT GUESS...
0129 0291 20 FA 02 JSR PLAY
0130 0294 E6 01 ENDCHK INC GESNO #ONE MORE GUESS TAKEN.
0131 0296 A5 00 LDA DIGITS
0132 0298 C5 01 CMP GESNO #ALL DIGITS GUESSED?
0133 029A D0 AB BNE KEY #IF NOT, GET NEXT.
0134 029C A5 02 LDA ERRS #GET NUMBER OF ERRORS.
0135 029E C9 00 CMP #0 #ANY ERRORS?
0136 02A0 F0 15 BEQ WIN #IF NOT, PLAYER WINS.
0137 02A2 20 CF 02 LOSE JSR LIGHT #SHOW NUMBER OF ERRORS.
0138 02A5 A9 09 LDA #9 #PLAY 8 DESCENDING TONES
0139 02A7 48 LOSELP PHA
0140 02A8 20 FA 02 JSR PLAY
0141 02AB 68 PLA

```

Fig. 8.5: Echo Program (Continued)

```

0142 02AC 38 SEC
0143 02AD E9 01 SRC #1
0144 02AF D0 F6 BNE LOSELP
0145 02B1 85 01 STA GESNO #CLEAR VARIABLES
0146 02B3 85 02 STA ERRS
0147 02B5 F0 8D BEQ KEY #GET NEXT GUESS SEQUENCE
0148 02B7 A9 FF WIN LDA #*FF #TURN ALL LEDS ON FOR WIN
0149 02B9 8D 01 A0 STA PORT1A
0150 02BC 8D 00 A0 STA PORT1B
0151 02BF A9 01 LDA #1 #PLAY 8 ASCENDING TONES
0152 02C1 48 WINLP PHA
0153 02C2 20 FA 02 JSR PLAY
0154 02C5 68 PLA
0155 02C6 18 CLC
0156 02C7 69 01 ADC #01
0157 02C9 C9 0A CMP #10
0158 02CB D0 FA BNE WINLP
0159 02CD F0 84 BEQ STRTJP #USE DOUBLE-JUMP FOR RESTART
0160 02CF ;
0161 02CF #ROUTINE TO LIGHT NTH LED, WHERE N IS
0162 02CF #THE NUMBER PASSED AS A PARAMETER IN
0163 02CF #THE ACCUMULATOR.
0164 02CF ;
0165 02CF 48 LIGHT PHA #SAVE A
0166 02D0 A8 TAY #USE A AS COUNTER IN Y
0167 02D1 A9 00 LDA #0 #CLEAR A FOR BIT SHIFT
0168 02D3 8D 00 A0 STA PORT1B #CLEAR HI LEDS.
0169 02D6 38 SEC #GENERATE HI BIT TO SHIFT LEFT.
0170 02D7 2A LSHFT ROL A #MOVE HI BIT LEFT.
0171 02D8 88 DEY #DECREMENT COUNTER
0172 02D9 D0 FC BNE LSHFT #SHIFTS DONE?
0173 02DB 8D 01 A0 STA PORT1A #STORE CORRECT PATTERN
0174 02DE 90 05 BCC LTCC #BIT 9 NOT HI, DONE.
0175 02E0 A9 01 LDA #1
0176 02E2 8D 00 A0 STA PORT1B #TURN LED 9 ON.
0177 02E5 68 LTCC PLA #RESTORE A
0178 02E6 60 RTS #DONE.
0179 02E7 ;
0180 02E7 #RANDOM NUMBER GENERATOR: RETURNS W/ NEW
0181 02E7 #RANDOM NUMBER IN A.
0182 02E7 ;
0183 02E7 38 RANDOM SEC
0184 02E8 A5 10 LDA RND+1
0185 02EA 65 13 ADC RND+4
0186 02EC 65 14 ADC RND+5
0187 02EE 85 0F STA RND
0188 02F0 A2 04 LDX #4
0189 02F2 B5 0F RNDLP LDA RND,X
0190 02F4 95 10 STA RND+1,X
0191 02F6 CA DEX
0192 02F7 10 F9 BPL RNDLP
0193 02F9 60 RTS
0194 02FA ;
0195 02FA #ROUTINE TO PLAY TONE WHOSE NUMBER IS PASSED
0196 02FA #IN BY ACCUM. IF ENTERED AT PLYTON, IT WILL
0197 02FA #PLAY TONE WHOSE LENGTH IS IN DUR, FREQUENCY
0198 02FA #IN ACCUMULATOR.
0199 02FA ;
0200 02FA AB PLAY TAY #USE TONE# AS INDEX...
0201 02FB 88 DEY #DECREMENT TO MATCH TABLES
0202 02FC B9 27 03 LDA DURTAB,Y #GET DURATION FOR TONE# N.
0203 02FF 85 03 STA DUR #SAVE IT.
0204 0301 B9 1E 03 LDA NOTAB,Y #GET FREQ. CONST FOR TONE# N
0205 0304 85 04 PLYTON STA FREQ #SAVE IT.
0206 0306 A9 00 LDA #0 #SET SPKR PORT LO.
0207 0308 8D 00 AC STA PORT3B
0208 030B A6 03 LDX DUR #GET DURATION IN # OF 1/2 CYCLES.
0209 030D AA 04 FL2 LDY FREQ #GET FREQUENCY
0210 030F 88 FL1 DEY #COUNT DOWN DELAY...
0211 0310 18 CLC #WASTE TIME
0212 0311 90 00 BCC #+2

```

Fig. 8.5: Echo Program (Continued)

```

0213 0313 D0 FA          BNE FL1 ;LOOP FOR DELAY
0214 0315 49 FF          EOR #$FF ;COMPLEMENT PORT
0215 0317 8D 00 AC       STA PORT3B
0216 031A CA            DEX ;COUNT DOWN DURATION...
0217 031B D0 F0          BNE FL2 ;LOOP TIL NOTE OVER.
0218 031D 60            RTS ;DONE.
0219 031E                ;
0220 031E                ;TABLE FOR NOTE FREQUENCIES.
0221 031E                ;
0222 031E C9            NOTAB .BYTE $C9,$BE,$A9,$96,$8E,$7E,$70,$64,$5E
0222 031F BE
0222 0320 A9
0222 0321 96
0222 0322 8E
0222 0323 7E
0222 0324 70
0222 0325 64
0222 0326 5E
0223 0327                ;
0224 0327                ;TABLE FOR NOTE DURATIONS.
0225 0327                ;
0226 0327 6B            DURTAB .BYTE $6B,$72,$80,$8F,$94,$AA,$BF,$D7,$E4
0226 0328 72
0226 0329 80
0226 032A 8F
0226 032B 94
0226 032C AA
0226 032D BF
0226 032E D7
0226 032F E4
0227 0330                .END

SYMBOL TABLE
SYMBOL      VALUE
CORECT      028E  DDR1A  A003  DDR1B  A002  DDR3B  A002
DELAY       026B  DIGITS  0000  DIGKEY  0220  DUR    0003
DURTAB      0327  ENDCHK  0294  ERRS    0002  EVAL   027B
FILL        022F  FL1     030F  FL2     030D  FREQ   0004
GESNO       0001  GETKEY  0100  KEY     0244  LIGHT  02CF
LOSE        02A2  LOSELP  02A7  LTCC    02E5  LSHFT  02B7
NOTAB       031E  PLAY    02FA  PLYTON  0304  PORT1A A001
PORT1B      A000  PORT3B  A000  RANDOM  02E7  RND     000F
RNDLP       02F2  SHOW    0259  SHOWLP  025F  START  0200
STRTJP      0253  TICL    A004  TABLE  0006  TEMP   0005
WIN         02B7  WINLP   02C1  WRONG   02B1

END OF ASSEMBLY

```

Fig. 8.5: Echo Program (Continued)

the difficulty of the game by increasing or decreasing the duration during which each note is played. Clearly, reducing the duration makes the game more difficult. Increasing the duration will usually make it easier, up to a point. You are encouraged to try variations.

The main variables used by the program are the following:

DIGITS contains the number of digits in the sequence to be recognized.

GESNO indicates the number of the current guess, i.e., which of the notes in the series the user is attempting to recognize.

ERRS indicates the number of errors made by the player so far.

TABLE is the table containing the sequence to be recognized.

A few other memory locations are reserved for passing parameters to subroutines or as scratch-pad storage. They will be described within the context of the associated routines.

As usual, the program starts by setting the data direction registers for Port 1A, Port 1B and Port 3B to an output configuration:

```

START      LDA #$FF
           STA DDR1A
           STA DDR1B
           STA DDR3B

```

Next, all LEDs on the board are turned off:

```

LDA #0
STA PORT1A

```

and the two variables, ERRS and GESNO, are set to 0:

```

STA ERRS
STA GESNO

```

The random number generator is primed by obtaining a seed and storing it at locations RND + 1 and RND + 4:

```

LDA TICL          Read timer counter.
STA RND + 1
STA RND + 4

```

The game is now ready to start. LED 10 must be turned on to indicate to the player that the game is ready:

```

LDA #%010        Pattern for LED 10
STA PORT1B       Specify length

```

The keyboard is scanned for the player input using the usual GETKEY subroutine (described in Chapter 1):

```

DIGKEY      JSR GETKEY

```

It is checked for the value "0":

CMP #0
BEQ DIGKEY If = 0, get another one

If the entry was "0," the program waits for another keystroke. Otherwise, it is compared to the value 10:

CMP #10 Sequence longer than 9
BPL DIGKEY

If the sequence length is greater than 9, it is also rejected. Accepting only valid inputs, using a bracket is known as "reasonableness testing" or "bracket-filtering."

If all is fine, the length of the sequence to be recognized is stored at memory location DIGITS:

STA DIGITS Length of sequence

A running pointer is then computed and stored at location TEMP. It is equal to the previous length minus 1:

FILL TAX Use X for computation
 DEX Decrement
 STX TEMP

The RANDOM subroutine is then called to provide a first random number:

JSR RANDOM

The position pointer in the series of notes now being generated is retrieved from TEMP, and stored in index register X in anticipation of storing the new random number in TABLE:

LDX TEMP

The value of the random number contained in the accumulator is then converted to a decimal value between 0 and 9. This process can be performed in various ways. Here, we take advantage of the special decimal mode available on the 6502. The decimal mode is set by specifying:

SED Set decimal mode

Note that the carry flag must be cleared, prior to an addition:

CLC Clear carry

The trick used here is to add "0" to the random number contained in the accumulator. The result in the right part of A is guaranteed to be a digit between 0 and 9, since we are operating in the decimal mode. Naturally, any other number could also be added to A to make its contents "decimal"; however, this would change the distribution of the random numbers, and some numbers in the series such as 0, 1, and 2 might never appear. Once this conversion has been performed, the decimal mode is simply turned off:

ADC #0 Add "0" in decimal mode
CLD Clear decimal mode

This is a powerful 6502 facility used to a great advantage in this instance. In order to guarantee that the result left in A be a decimal number between 0 and 9, the upper nibble of the byte is removed by masking it off:

AND #\$0F

Finally, a value of "0" is not allowed, and a new number must be obtained if this is the current value of the accumulator:

BEQ FILL

Exercise 8-2: *Could we avoid this special case for "0" by adding a value other than "0" to A above?*

If this is not the current value of the accumulator, we have a decimal number between 1 and 9 that is reasonably random, which can now be stored in the table. Remember that index register X has been preloaded with the current number's position in the sequence (retrieved from memory location TEMP). It can be used, as is, as an index:

STA TABLE,X Store # in table

The number pointer is then decremented in anticipation of the next iteration:

DEX

and the loop is reentered until the table of random numbers becomes full:

BPL FILL

We are now ready to play. LED 12 will be turned on, signaling to the player that he or she may enter a guess:

```
KEY      LDA #0
          STA PORT1A
          LDA #0100
          STA PORT1B
```

The player's guess is then read from the keyboard:

```
JSR GETKEY      Get guess
```

It must be tested for "0" or for an alphabetic value. Let us test for "0":

```
STRTJP      CMP #0          Is it 0?
            BEQ START      If yes, restart
```

If it is "0," the game is restarted, and a branch occurs to location START. If it is not "0," we must check for an alphabetic character:

```
            CMP #10        Number <10?
            BMI EVAL       If yes, evaluate correctness
```

If the value of the input keystroke is less than ten, it is a guess and is evaluated with the EVAL routine. Otherwise, the program executes the SHOW routine to display the series.

The SHOW Routine

We will assume here that an alphabetic key has been pressed. BMI fails, and we enter the SHOW routine. This routine plays the computer-generated tune and lights up the corresponding sequence of LEDs. Also, whenever this routine is entered, the guessing sequence is

restarted and the temporary variables are reset to 0:

```
SHOW      LDX #0
          STX GESNO
          STX ERRS          Reset all variables
```

The first table entry is obtained, the corresponding LED is lit, and the corresponding tone is played:

```
SHOWLPL  LDA TABLE,X    Get Xth entry in table
          STX TEMP        Save X
          JSR LIGHT       Light LED # TABLE (X)
          JSR PLAY        Play tone # TABLE (X)
```

An internote delay is then implemented using Y as the loop counter and two dummy instructions to extend the delay:

```
DELAY    LDY #$FF
          ROR DUR         Dummy instruction
          ROL DUR         Dummy
          DEY             Count down
          BNE DELAY       End of loop test
```

We are now ready to perform the same operation for the next note in the current table. The index pointer is restored and incremented:

```
LDX TEMP      Restore X
INX           Increment it
```

It is then compared to the maximum number of digits stored in the table. If the maximum has been reached, the display operation is complete and we go back to label KEY. Otherwise, the next tone is sounded, and we go back to label SHOWLPL:

```
CPX DIGITS    All digits shown?
BNE SHOWLPL
BEQ KEY       Done, get next input
```

The EVAL Routine

Let us now examine the routine which evaluates the guess of the

player. It is the EVAL routine. The value of the corresponding entry in TABLE is obtained and compared to the player's input:

| | | |
|------|-------------|--------------------------|
| EVAL | LDX GESNO | Load guess number into X |
| | CMP TABLE,X | Compare guess to number |
| | BEQ CORECT | If correct, tell player |

If there is a match, a branch occurs to location CORECT; otherwise, the program proceeds to label WRONG. Let us examine this case. If the guess is wrong, one more error is recorded:

| | |
|-------|----------|
| WRONG | INC ERRS |
|-------|----------|

A low tone is played:

| | |
|------------|---------|
| LDA #\$80 | |
| STA DUR | |
| LDA #\$FF | |
| JSR PLYTON | Play it |

A jump then occurs to location ENDCHK:

| | |
|------------|-----------------------|
| BEQ ENDCHK | Check for end of game |
|------------|-----------------------|

Exercise 8-3: *Examine the BEQ instruction above. Will it always result in a jump to label ENDCHK? (Hint: determine whether or not the Z bit will be set at this point.)*

Exercise 8-4: *What are the merits of using BEQ (above) versus JMP?*

Now we shall consider what happens in the case of a correct guess. If the guess is correct, we light up the corresponding LED and play the corresponding tone. Both subroutines assume that the accumulator contains the specified number:

| | | |
|--------|-----------|----------------------|
| CORECT | JSR LIGHT | Turn on LED |
| | JSR PLAY | Play note to confirm |

We must now determine whether we have reached the end of a sequence or not, and take the appropriate action. The number of guesses is incremented and compared to the maximum length of the

stored tune:

| | | |
|--------|------------|------------------------------|
| ENDCHK | INC GESNO | One more guess |
| | LDA DIGITS | |
| | CMP GESNO | All digits guessed? |
| | BNE KEY | If not, get next key closure |

If we are not done yet, a branch occurs back to label KEY. Otherwise, we have reached the end of a game and must signal either a "win" or a "lose" situation. The number of errors is checked to determine this:

| | |
|----------|----------------------|
| LDA ERRS | Get number of errors |
| CMP #0 | No error? |
| BEQ WIN | If not, player wins |

If a "win" is identified, a branch occurs to label WIN. This will be described below. Let us examine now what happens in the case of a "lose":

| | | |
|------|-----------|-----------------------|
| LOSE | JSR LIGHT | Show number of errors |
|------|-----------|-----------------------|

The number of errors is displayed by lighting up the corresponding LED. Remember that the accumulator was conditioned prior to entering this routine and contained the value of ERRS, i.e., the number of errors so far.

Next, a sequence of eight descending tones is played. The top of the stack is used to contain the remaining number of tones to be played:

| | | |
|--------|----------|-------------------------|
| LOSELP | LDA #9 | Play 8 descending tones |
| | PHA | Save A on stack |
| | JSR PLAY | Play tone |
| | PLA | Restore A |

Once a tone has been played, the remaining number of tones to be played is decremented by one and tested for "0":

| | |
|------------|--------------------------|
| SEC | Set carry (for subtract) |
| SBC #1 | Subtract one |
| BNE LOSELP | |

Exercise 8-5: *Note how the top of the stack has been used as a tem-*

porary scratch location. Can you suggest an alternative way to achieve the same result without using the stack?

Exercise 8-6: Discuss the relative merits of using the stack versus using other techniques to provide temporary working locations for the program. Are there potential dangers inherent in using the stack?

Eight successive tones are played. Then the two work variables, GESNO and ERRS, are reset to "0," and a branch occurs back to the beginning of the program:

```

STA GESNO      Clear variables
STA ERRS
BEQ KEY        Get next guess sequence

```

Let us examine now what happens in a "win" situation. All LEDs on the Games Board are turned on simultaneously:

```

WIN           LDA #$FF      It is a win: turn all LEDs on
              STA PORT1A
              STA PORT1B

```

Next, a sequence of eight ascending tones is played. The tone number is stored in the accumulator and will be used as an index by the PLAY subroutine to generate an appropriate note. As before, the top of the stack is used to provide working storage:

```

WINLP        LDA #1         A will be incremented to 9
              PHA           Save A on the stack
              JSR PLAY
              PLA

```

The number of tones which have been played is then incremented by 1 and compared to the maximum value of 9:

```

              CLC           Clear carry for addition
              ADC #01
              CMP #10

```

As long as the maximum of 9 has not been reached, a branch occurs back to label WINLP:

```

              BNE WINLP

```

Otherwise, a new game is started:

```

              BEQ STRTJP     Double jump for restart

```

This completes the description of the main program. Three subroutines are used by this program. They will now be described.

The Subroutines

LIGHT Subroutine

This subroutine assumes that the accumulator contains the number of the LED to be lit. The subroutine will light up the appropriate LED on the Games Board. It will achieve this result by writing a "1" in the appropriate position in the accumulator and then sending it to the appropriate output port. Either Port 1A will be used (for LEDs 1 through 8) or Port 1B (for LED 9). The "1" bit is written in the appropriate position in the accumulator by performing a sequence of shifts. The number of shifts is equal to the position of the LED to be lit. Index register Y is used as a shift-counter. The number of the LED to be lit is saved in the stack at the beginning of the subroutine and will be restored upon exit. Note that this is a classic way to preserve the contents of an essential register during subroutine execution so that the contents of the accumulator will be unchanged upon subroutine exit. If this was not the case, the calling program would have to explicitly preserve the contents of the accumulator prior to calling the LIGHT subroutine. Then it might have to load it back into the accumulator prior to using another one of the routines, such as the PLAY routine. Because LIGHT and PLAY are normally used in sequence, it is more efficient to make it the subroutine's responsibility to save the contents of the accumulator. Let us do it:

```

LIGHT        PHA           Preserve A

```

The shift-counter is then set up:

```

              TAY           Use Y as shift counter

```

and the accumulator is initialized to "0":

LDA #0 Clear A

LED 9 is turned off in case it was lit:

STA PORT1B

The shifting loop is then implemented. The carry bit is initially set to "1," and it will be shifted left in the accumulator as many times as necessary:

```

                SEC            Set carry
LTSHFT        ROL A
                DEY
                BNE LTSHFT

```

The correct bit pattern is now contained in the accumulator and displayed on the Games Board:

STA PORT1A

However, one special case may arise: if LED 9 has been specified, the contents of the accumulator are "0" at this point, but the carry bit has been set to "1" by the last shift. This case must be explicitly tested for:

BCC LTCC Is bit 9 set?

If this situation exists, the accumulator must be set to the value "00000001," and output to Port 1B:

```

LDA #1
STA PORT1B        Turn LED 9 on

```

We finally exit from the routine without forgetting to restore the accumulator from the stack where it had been saved:

```

LTCC            PLA            Restore A
                RTS

```

Exercise 8-7: List the registers destroyed or altered by this subroutine every time it is executed.

Exercise 8-8: Assume that register Y must be left unchanged upon leaving this subroutine. What are the required program changes, if any?

RANDOM Subroutine

This subroutine generates a new random number and returns its value in A. Its operation has been described in Chapter 4.

PLAY Subroutine

This subroutine will normally play the tone corresponding to the number contained in the accumulator. Optionally, it may be entered at location PLYTON and will then play the tone corresponding to the frequency set by the accumulator and corresponding to the length specified by the contents of memory location DUR. Let us examine it.

Index register Y is used as an index to the two tables required to determine the note duration and the note frequency. In this game, up to 9 notes may be played, corresponding to LEDs and keys 1 through 9. Index register Y is first conditioned:

```

PLAY            TAY            Use tone # as index
                DEY            Decrement to internal value

```

Note that the index register must be decremented by one. This is because key 1 corresponds to entry number 0 in the table, and so on. The duration and frequencies are obtained from tables DURTAB and NOTAB using the indexed addressing mode. They are stored respectively at locations DUR and FREQ:

```

                LDA DURTAB,Y    Get duration
                STA DUR        Save it
                LDA NOTAB,Y    Get frequency
PLYTON        STA FREQ        Save it

```

The speaker is then turned off:

```

LDA #0
STA PORT3B        Set speaker Port 3B

```

Two loops will now be implemented. An inner loop will use register Y as the delay-counter to implement the correct frequency for the note.

Register X will be used in the outer loop and will generate the tone for the appropriate duration of time.

Let us condition the two counter registers:

```

                LDX DUR      Get duration in # of 1/2 cycles
FL2            LDY FREQ      Get frequency

```

Next, let us implement the inner loop delay:

```

FL1            DEY
                CLC          Waste time
                BCC * + 2
                BNE FL1      Delay loop

```

Note that two “do-nothing” instructions have been placed inside the loop to generate a longer delay. At the end of this inner loop delay the contents of the output port connected to the loudspeaker are complemented in order to generate a square wave.

```

                EOR #$FF      Complement port

```

Note that, once more, EOR #\$FF is used to complement the contents of a register.

```

                STA PORT3B

```

The outer loop can then be completed:

```

                DEX
                BNE FL2      Outer loop
                RTS

```

SUMMARY

This program demonstrates how simple it is to implement electronic keyboard games that sound for input/output and that are challenging to adult players.

Exercise 8-9: *The duration and frequency constants for the nine notes are shown in Figure 8.6. What are the actual frequencies generated by the program?*

| NOTE | FREQUENCY CONSTANT | DURATION CONSTANT |
|------|-----------------------|----------------------|
| 1 | C9 | 6B |
| 2 | BE | 72 |
| 3 | A9 | 80 |
| 4 | 96 | 8F |
| 5 | 8E | 94 |
| 6 | 7E | AA |
| 7 | 70 | BF |
| 8 | 64 | D7 |
| 9 | 5E | E4 |

Fig. 8.6: Frequency and Duration Constants

9

MINDBENDER

THE RULES

This game is inspired by the commercial game of MasterMind (trademarked by the manufacturer, Invicta Plastics, Ltd.). In this game, one or more players compete against the computer (and against each other). The computer generates a sequence of digits — for example, a sequence of five digits between “0” and “9” — and the player attempts to guess the sequence of five numbers in the correct order. The computer responds by telling the player how many of the digits have been guessed accurately, and how many were guessed in their correct location in the numerical sequence.

LEDs 1 through 9 on the Games Board are used to display the computer’s response. A blinking LED is used to indicate that the player’s guess contains a correct digit which is located in the right position in the sequence. A steadily lit LED is used to indicate a digit correctly guessed but appearing out of sequence. Several players can match their skills against each other. For a given complexity level — say, for guessing a sequence of seven digits—the player that can correctly guess the number sequence with the fewest guesses is the winner.

The game may also be played with a handicap whereby a given player has to guess a sequence of n digits while the other player has to guess a sequence of only $n - 1$ digits. This is a serious handicap, since increasing the level of difficulty by one is quite significant.

A TYPICAL GAME

Both audio and visual feedback are used to play this game.

The Audio Feedback

Every time that a player has entered his or her sequence of guesses, the computer responds by sounding a specific tone. A low tone indicates an incorrect guess; a high tone indicates that the sequence was guessed correctly.

The Visual Feedback

At the beginning of each game, LED #10 is lit, requesting the length of the sequence to be guessed. This is shown in Figure 9.1. The player then specifies the sequence length as a number from 1 through 9. Any other input will be ignored.

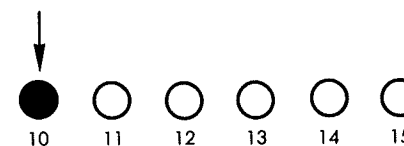

Fig. 9.1: Enter Length of Sequence

As soon as the length has been specified, for example, let’s say the length “2” has been selected, LED #11 lights up. This means “Enter your guess.” (See Figure 9.2.) At this point the player enters his or her guess as a sequence of two digits. Let us now play a game.

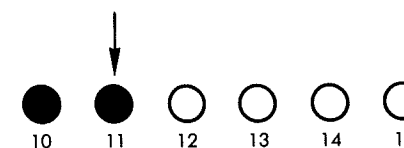

Fig. 9.2: Enter Your Guess

The player types in the sequence “1,2.” A low tone sounds, LEDs 10 and 11 go out briefly, but nothing else happens. The situation is indicated in Figure 9.3. Since LEDs 1 through 9 are blank, there is no correct digit in the guess. Digits “1” and “2” must be eliminated. Let us try another guess.

We type “3,4.” A low tone sounds, but this time LED #1 is steadily on, as indicated in Figure 9.4. From this we know that either “3” or

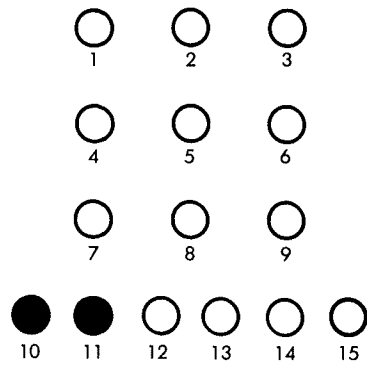

Fig. 9.3: Player Enters Wrong Guess

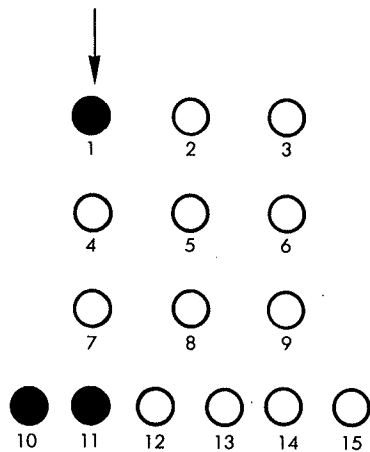

Fig. 9.4: One Correct Digit in the Correct Position

“4” is one of the digits and that it belongs in the other position. Conversely, the sequence “4,3,” must have one good digit in the right position. Just to be sure let us perform a test.

We now type “4,3.” A low tone sounds, indicating that the sequence is not correct, but this time LED #1 is on and blinking. This proves that our reasoning is correct, and we proceed.

We now try “4,5.” A high-pitched sound is heard and LEDs 1 and 2

light up briefly, indicating that those digits have been guessed correctly and that we have won our first game.

At the end of the game, the situation reverts to the one at the beginning, as indicated in Figure 9.1. Note that typing in a value other than “1” through “9” as a guess will restart the game.

There is a peculiarity to the game: if the number to be guessed contains two identical digits, and the player enters this particular digit in one of its two correct locations, the computer response will indicate this digit as being both the right digit in the right place and the right digit in the wrong place!

THE ALGORITHM

The flowchart for Mindbender is shown in Figure 9.5. Interrupts are used to blink the LEDs. Interrupts will be generated automatically by the programmable interval timer of VIA #1 at approximately 1/15th-of-a-second intervals.

Referring to Figure 9.5, all of the required registers and memory locations will be initialized first. Next (box 2 on the flowchart), the length of the sequence to be guessed is read from the keyboard. The validity bracket “1” to “9” is used to “filter” the player’s input.

Next, a random sequence must be generated. In box 3 of the flowchart, a sequence of random numbers is generated and stored in a digit table, starting at address DIG0.

In box 5, the computer’s sequence of numbers is compared — one number at a time — with the player’s guess. The algorithm takes one digit from the computer sequence and matches it in order against every digit of the player sequence. As we have already indicated, this may result in lighting up two LEDs, if ever there are two or more identical digits in the number to be guessed and the player has specified only one digit. One digit may be flagged as being in the right place, and also as being correct but in the wrong location(s).

Note that, alternatively, another comparison algorithm could be used in which each digit of the player’s sequence is compared in turn with each digit of the computer’s sequence.

Once the digits have been compared, the resulting score is displayed on the LEDs (box 6). Finally, a test is made for a win situation (box 7), and the appropriate sound is generated (box 8).

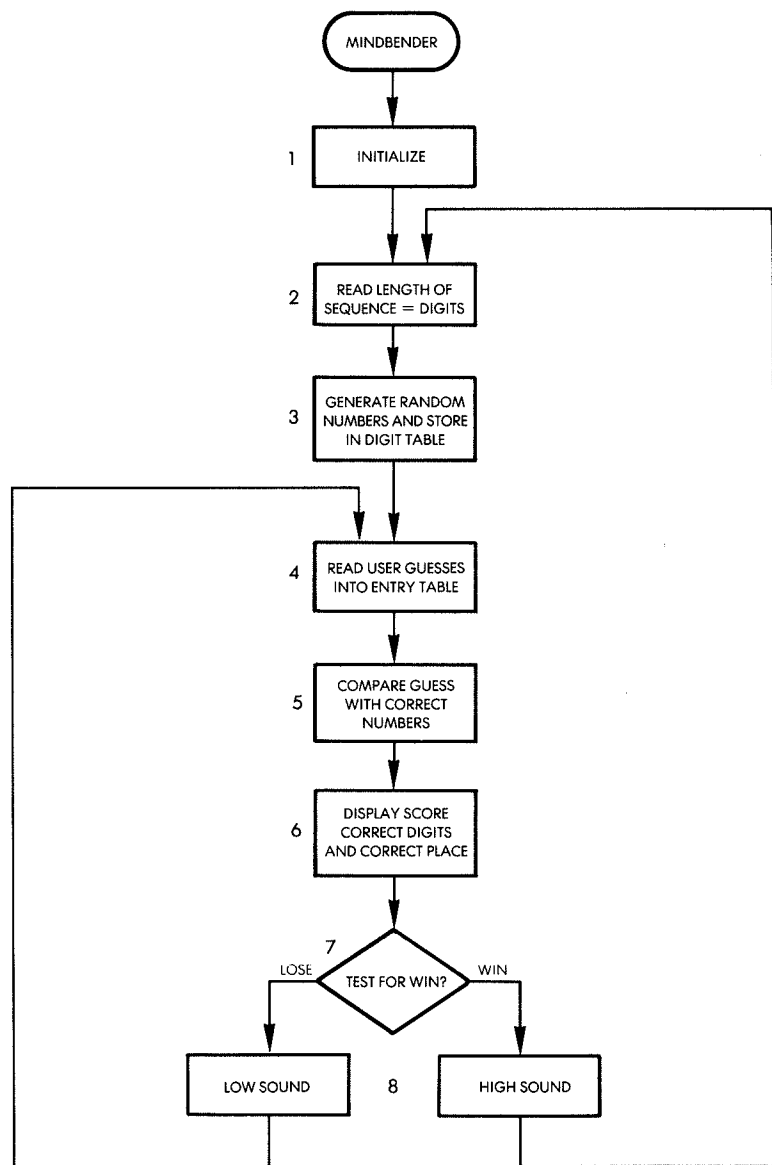

Fig. 9.5: Mindbender Flowchart

THE PROGRAM

Data Structures

Two tables of nine entries are used to store, respectively, the computer's sequence and the player's sequence. They are stored starting at addresses DIG0 and ENTRY0. (See Figure 9.6.)

The Variables

Page 0 is used, as usual, to provide additional working registers, i.e., to store the working variables. The use of page 0 is indicated as a "memory map" in Figure 9.6. The first nine locations are used for the program variables. The function of each variable is indicated in the illustration and will be described in detail as we examine the program below. Locations "09" through "0E" are reserved for the random table used to generate the random numbers. Locations "0F" through "17" are used for the DIG0 table used to store the computer-generated sequence of random numbers. Finally, locations "18" and following are used to contain the sequence of digits typed by the user.

The memory locations used for addressing input/output and for interrupt vectoring are shown in Figure 9.7. Locations "A000" through "A005" are used to address Ports A and B of VIA #1 as well as timer T1. The memory map for a 6522 VIA is shown in Figure 9.8.

Location "A00B" is used to access the auxiliary control register, while location "A00E" accesses the interrupt-enable register. For a detailed description of these registers the reader is referred to the *6502 Applications Book* (reference D302).

Memory locations "A67E" and "A67F" are used to set up the interrupt vector. The starting address of the interrupt-handling routine will be stored at this memory location. In our program, this will be address "03EA." This is the routine in charge of blinking the LEDs. It will be described below. Finally, Port 3 is addressed at memory locations "AC00" and "AC02."

Program Implementation

A detailed flowchart for the Mindbender program is shown in Figure 9.9. Let us now examine the program itself. (See Figure 9.13.)

The initialization block resides at memory addresses 0200-0239 hexadecimal and conditions interrupts and I/O. First, interrupts are conditioned. Prior to modifying the interrupt vector which resides at ad-

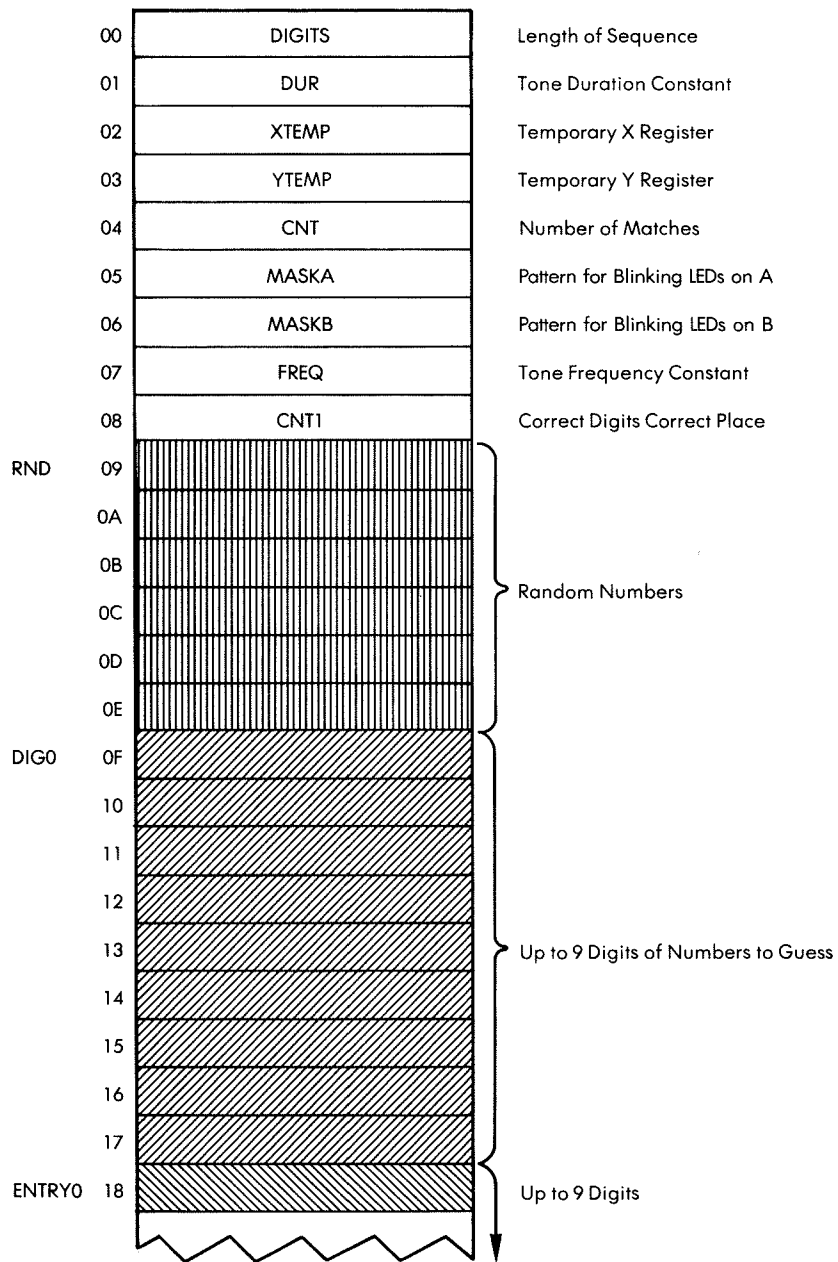

Fig. 9.6: Low Memory Map

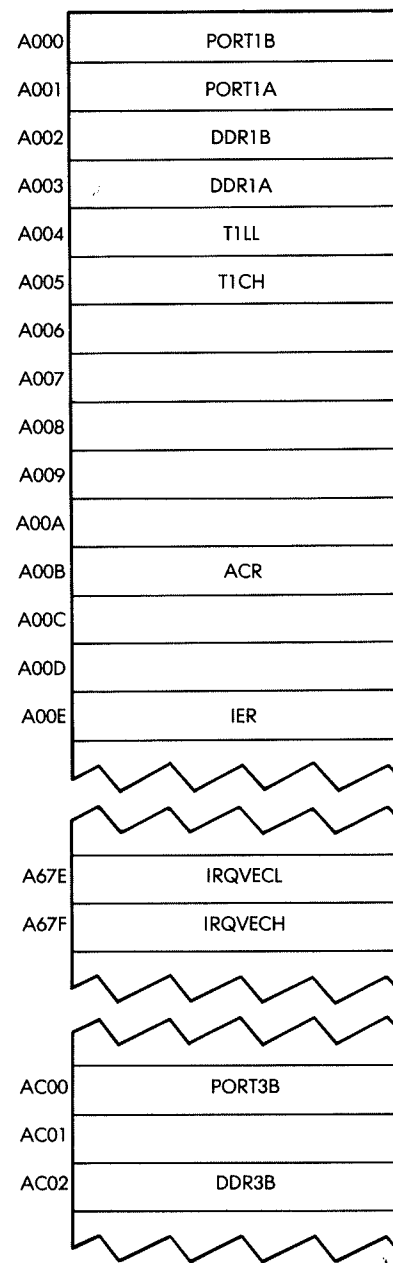

Fig. 9.7: High Memory Map

| | | | |
|----|-----------------------|--|-------------------|
| 00 | ORB (PB0 TO PB7) | I/O data, port A | |
| 01 | ORA (PA0 TO PA7) | Used for control-affects handshake | |
| 02 | DDR B | Data direction registers | } |
| 03 | DDR A | | |
| 04 | T1L-L/T1C-L | Counter-low | Timer 1 |
| 05 | T1C-H | Counter-high | |
| 06 | T1L-L | Latch-low | |
| 07 | T1L-H | Latch-high | |
| 08 | T2L-L/T2C-L | Latch-low | Timer 2 |
| 09 | T2C-H | Counter-high | |
| 0A | SR | Shift register | |
| 0B | ACR | Auxiliary | Function control |
| 0C | PCR (CA1,CA2,CB2,CB1) | Peripheral | |
| 0D | IFR | Flags | Interrupt control |
| 0E | IER | Enable | |
| 0F | ORA | Output register A (does not affect handshake) | |

Fig. 9.8: 6522 VIA Memory Map

addresses "A67E" and "A67F" (see Figure 9.7) access to this protected area of memory must be authorized. This is performed by the ACCESS subroutine, which is part of the SYM monitor:

JSR ACCESS

Next, the new interrupt vector can be loaded at the specified location. The value "03EA" is entered at address IRQVEC:

```
LDA #$EA      Low interrupt vector
STA IRQVECL
LDA #$03      High interrupt vector
STA IRQVECH
```

Now the internal registers of the 6522 VIA #1 must be conditioned to set up the interrupts. The interrupt-enable register (IER) will enable or disable interrupts. Each bit position in the IER matches the corresponding one in the interrupt flag register (IFR). Whenever a bit position is "0," the corresponding interrupt is disabled. Bit 7 of IER plays a special role. (See Figure 9.10.) When IER bit 7 is "0," each "1" in the remaining bit positions of IER will clear the corresponding enable flag. When IER bit 7 is "1," each "1" written in IER will play its normal role and set an enable. All interrupts are, therefore, disabled by setting bit 7 to "0" and all remaining bits in the IER to ones:

```
LDA #$7F
STA IER
```

Next, bit 6, which corresponds to the timer 1 interrupt, is enabled. In order to do this, bit 7 of IER is set to "1," as is bit 6:

```
LDA #$C0
STA IER
```

Next, timer 1 will be set in the "free-running mode." Remember that, with the 6522, the timer can be used in either the "one-shot" mode or the "free-running mode." Bits 6 and 7 of the auxiliary control register are used to select timer 1 operating modes. (See Figure 9.11.) In this instance, bit 7 is set to "0" and bit 6 is set to "1":

```
LDA #$40
STA ACR
```

Prior to using the timer in the output mode, its counter-register must be loaded with a 16-bit value. This value specifies the duration of the square pulse to be generated. The maximum value "FFFF" is used here:

```
LDA #$FF
STA T1LL
STA T1CH
```

The actual wave form from timer 1 is shown in Figure 9.12. In order to compute the exact duration of the pulse, note that the pulse dura-

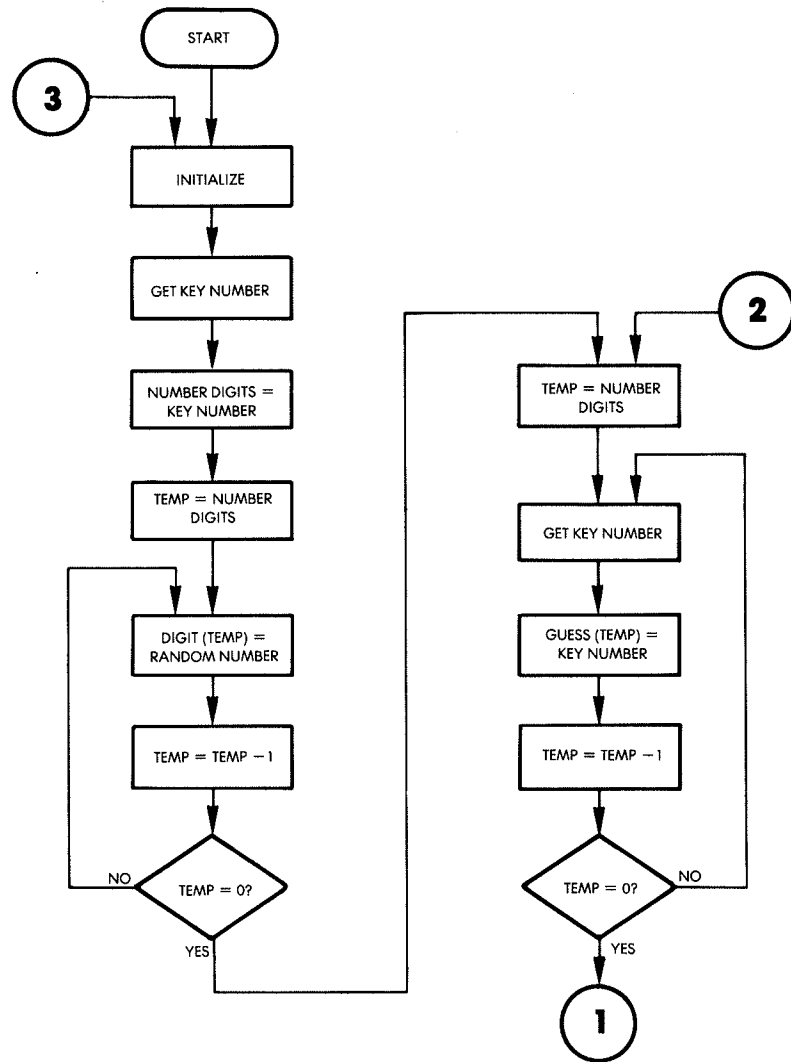

Fig. 9.9: Detailed Mindbender Flowchart

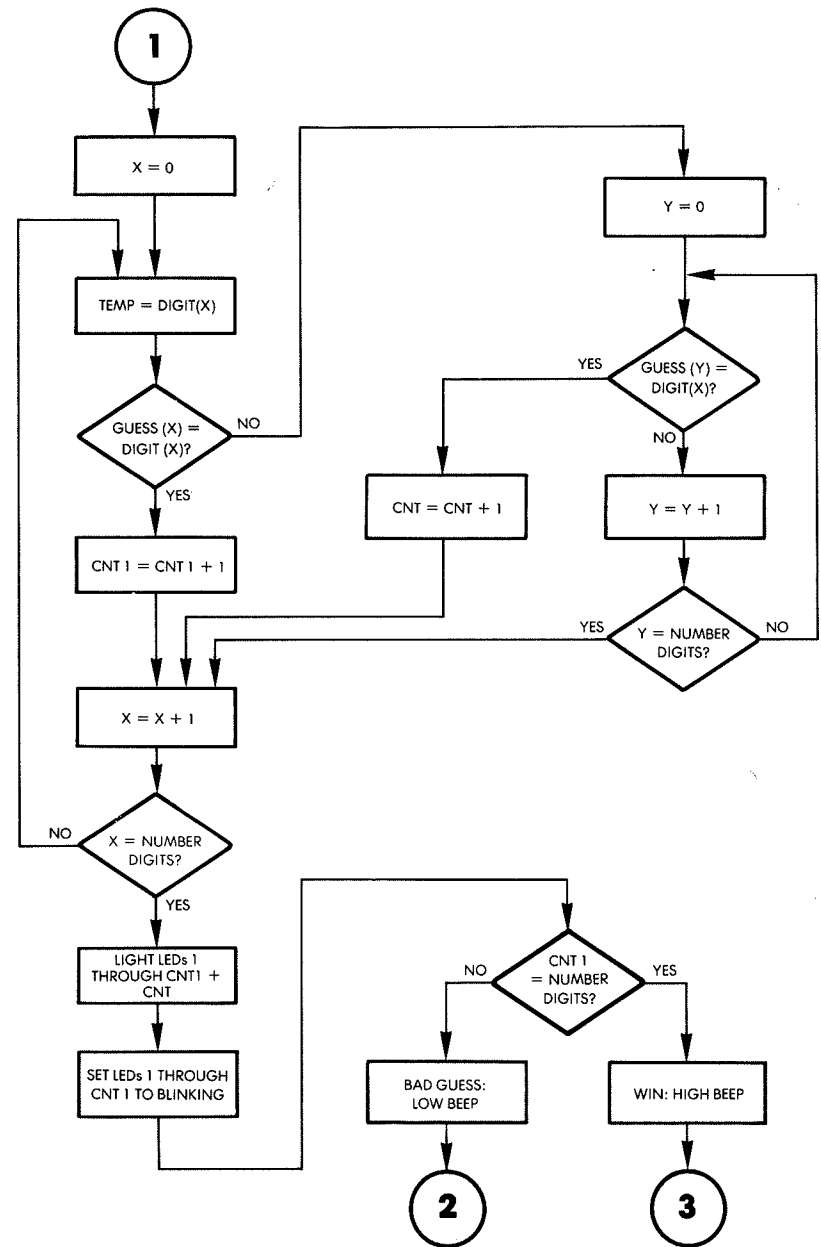

Fig. 9.9: Detailed Mindbender Flowchart (Continued)

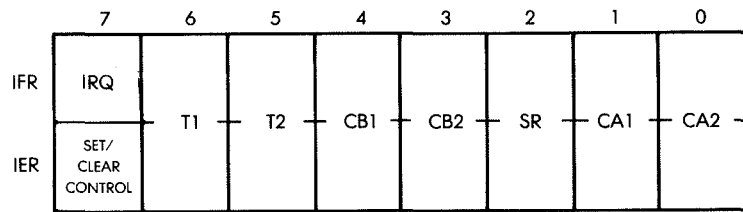

Fig. 9.10: Interrupt Registers

tion will alternate between $n + 1.5$ cycles and $n + 2$ cycles, where n is the initial value loaded in the counter register.

Next, interrupts are enabled:

CLI

and the three ports used by this program are configured in the appropriate direction:

```

STA DDR1A      Output
STA DDR1B      Output
STA DDR3B      Output
    
```

All LEDs are then cleared:

| ACR7 OUTPUT ENABLE | ACR6 INPUT ENABLE | MODE |
|--------------------------|-------------------------|---|
| 0 | 0 (ONE-SHOT) | GENERATE TIME OUT INT WHEN T1 LOADED PB7 DISABLED |
| 0 | 1 (FREE RUN) | GENERATE CONTINUOUS INT PB7 DISABLED |
| 1 | 0 (ONE-SHOT) | GENERATE INT AND OUTPUT PULSE ON PB7 EVERYTIME T1 IS LOADED = ONE-SHOT AND PROGRAMMABLE WIDTH PULSE |
| 1 | 1 (FREE RUN) | GENERATE CONTINUOUS INT AND SQUARE WAVE OUTPUT ON PB7 |

Fig. 9.11: 6522 Auxiliary Control Register Selects Timer 1 Operating Modes

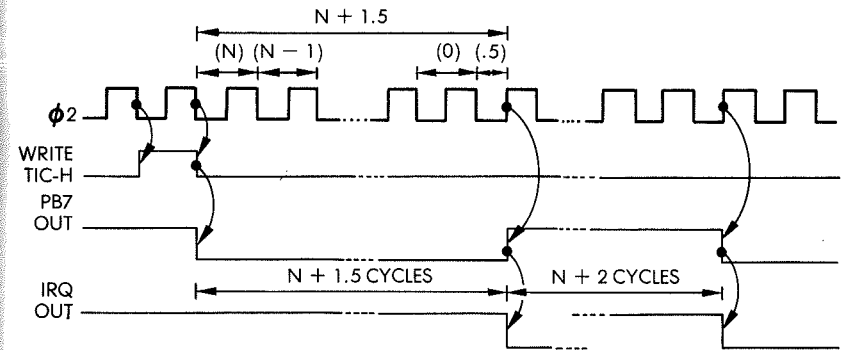

Fig. 9.12: Timer 1 in Free Running Mode

```

KEY1      LDA #0
           STA PORT1A
           STA PORT1B
    
```

and the blink masks are initially set to all 0's:

```

           STA MASKA
           STA MASKB
    
```

LED 10 is now turned on in order to signal to the player that he or she should specify the number of digits to be guessed:

```

           LDA #%00000010  Select LED 10
           STA PORT1B      Turn it on
    
```

The key pressed is read using the usual GETKEY routine:

```

           JSR GETKEY      Get # digits
    
```

A software filter is implemented at this point. The value of the key read from the keyboard is validated as falling within the range "1" through "9." If it is greater than 9, or less than 1, the entry is ignored:

```

           CMP #10
           BPL KEY1
           CMP #0
           BEQ KEY1
    
```

Once validated, the length specified for the sequence is stored at memory location DIGITS:

```
STA DIGITS
```

A sequence of random numbers must now be generated.

Generating a Sequence of Random Numbers

The initial random number is obtained from the counter and used to start the random number generator. The theory behind this technique has been described before.

Locations RND + 1, RND + 4, and RND + 5 are seeded with the same number:

```
LDA TILL
STA RND + 1
STA RND + 4
STA RND + 5
```

Then a random number is obtained using the RANDOM subroutine:

| | | |
|------|------------|--------------------------|
| | LDY DIGITS | Get # of digits to guess |
| | DEY | Count to 0 |
| RAND | JSR RANDOM | Filling them with values |

The resulting random number is set to a BCD value which guarantees that the last digit will be between 0 and 9:

```
SED
ADC #00      Decimal Adjust
CLD
```

It is then truncated to the lower 4 bits:

```
AND #$00001111
```

Once the appropriate random digit has been obtained, it is saved at the next location of the digit table, using index register Y as a running pointer:

```
STA DIG0,Y
```

The counter Y is then decremented, and the loop executed until all required digits have been generated:

```
DEY
BPL RAND
```

Collecting the Player's Guesses

Index register X will serve as a running pointer for the ENTRY table used to collect the player's guess. It is initialized to the value "0," and stored at memory location XTEMP:

| | | |
|-------|-----------|---------------|
| EXTRA | LDA #0 | Clear pointer |
| | STA XTEMP | |

LEDs 10 and 11 are then turned on to signal the player that he or she may enter his or her sequence:

```
LDA #$00000110
STA PORT1B
```

The key pressed by the player is read with the usual GETKEY routine:

| | |
|------|------------|
| KEY2 | JSR GETKEY |
|------|------------|

If the key pressed is greater than 9, it is interpreted as a request to restart the game:

```
CMP #10
BPL KEY1
```

Otherwise, the value of the index register X is retrieved from memory location XTEMP and is used to perform an indexed store of the accumulator to the appropriate location in the ENTRY table:

| | | |
|--|--------------|----------------------|
| | LDX XTEMP | |
| | STA ENTRY0,X | Store guess in table |

The running pointer is then incremented, and stored back in memory:

```

    INX
    STX XTEMP

```

Then, the value of the running pointer is compared to the maximum number of digits to be fetched from the keyboard and, as long as this number is not reached, a loop occurs back to location KEY2:

```

    CPX DIGITS      All numbers fetched?
    BNE KEY2        If not, get another

```

Once the player has entered his or her sequence, the digits must be compared to the computer-generated sequence. In anticipation of the display of a possible win the LEDs on the board are blanked and the masks are cleared:

```

    LDX #0
    STX PORT1A
    STX PORT1B
    STX MASKA
    STX MASKB

```

Two locations in memory will be used to contain the number of correct digits and the number of correct digits in the correct location. They are initially cleared:

```

    STX CNT          Number of matches
    STX CNT1         Number of correct digits

```

Each entry of the DIG0 table will now be compared in turn to all entries of the ENTRY0 table. Each digit is loaded from the DIGIT table and immediately compared to the corresponding ENTRY contents:

```

    DIGLP           LDA DIG0,X
                   CMP ENTRY0,X

```

If it is not the right digit at the right place, there is no exact match. We will then check to see if the digit appears at any other place within the ENTRY table:

```

    BNE ENTRYCMP

```

Otherwise, one more exact match is recorded by incrementing location CNT1, and the next digit is examined:

```

    INC CNT1
    BNE NEXTDIG

```

Let us examine now what happens when no match has occurred. The digit (of the number to be guessed) which has just been read and is contained in the accumulator should be compared to every digit within the ENTRY table. Index register Y is used as a running pointer, and the contents of the accumulator are compared in turn to each of the digits in ENTRY:

```

    ENTRYCMP       LDY #0
    ENTRYLP        CMP ENTRY0,Y
                   BNE NEXTENT

```

If a match is found, memory location CNT is incremented and the next digit is examined:

```

    INC CNT
    BNE NEXTDIG

```

Otherwise, index register Y is incremented. If the end of the sequence is reached, exit occurs to NEXTDIG. Otherwise a branch back occurs to the beginning of the loop at location ENTRYLP:

```

    NEXTENT        INY          Increment guess # pointer
                   CPY DIGITS   All tested?
                   BNE ENTRYLP  No: try next one

```

The next digit in table DIG must then be examined. The running pointer for DIG is contained in index register X. It is incremented and compared to its maximum value:

```

    NEXTDIG        INX          Increment digit # pointer
                   CPX DIGITS   All digits checked

```

If the limit has not been reached, a branch occurs back to the beginning of the outer loop at location DIGLP:

BNE DIGLP

At this point, we are ready to turn on the LEDs to display the results to the player.

Displaying the Results to the Player

The total number of LEDs which must be turned on is obtained by adding the contents of CNT to CNT1:

```
CLC           Get ready for add
LDA CNT
ADC CNT1
```

The total is contained in the accumulator and transferred into index register Y where it will be used by the LITE routine:

```
TAY
JSR LITE
```

The operation of the LITE routine will be described below. Its effect is to fill the accumulator with the appropriate number of ones in order to turn on the appropriate LEDs.

The pattern created by the LITE subroutine is then stored in the mask:

```
STA PORT1A
```

For the special case in which the result is 9, the carry bit will have been set. This case is explicitly tested:

```
BCC CC           If carry 0, don't light PB0.
```

and if the carry had been set to 1, Port B will be set appropriately so that LED #9 is turned on:

```
LDA #1           Turn PB0 on
STA PORT1B
```

Recall that once masks A and B have been set up, they will automatically be used by the interrupt handling routine which will

cause the appropriate LEDs to blink.

```
CC           LDY CNT1
             JSR LITE
             STA MASKA
             BCC TEST
             LDA #01
             STA MASKB
```

The program must now test for a win or lose situation.

Testing for a Win or Lose Situation

The number of correct digits in the right places is contained in CNT1. We will simply compare it to the length of the sequence to be guessed:

```
TEST          LDX CNT1
             CPX DIGITS
```

If these numbers are equal, the player has won:

```
BEQ WIN
```

Otherwise, a low tone will be sounded. The tone duration constant is set to "72," and its frequency value to "BE":

```
BAD           LDA #$72
             STA DUR
             LDA #$BE
```

The TONE subroutine is then used to generate the tone, as usual:

```
JSR TONE
```

Then a return occurs to the beginning of the program:

```
BEQ ENTER
```

If a win has occurred, a high-pitched tone will be generated. Its duration constant is set to "FF" and its pitch is controlled by setting the

frequency constant to "54":

```
WIN      LDA #$FF
          STA DUR
          LDA #$54
```

As usual, the TONE subroutine is used to generate the tone:

```
JSR TONE
```

The game is then restarted:

```
JMP KEY1
```

The Subroutines

Four routines are used by this program. They are: LITE, RANDOM, TONE, and INTERRUPT HANDLER. The RANDOM and TONE routines have been described in previous chapters and will not be described again here.

LITE Subroutine

When entering this subroutine, index register Y contains the number of LEDs which should blink. In order to make them blink it is necessary to load the appropriate pattern into the mask patterns called MASKA and MASKB. The appropriate number of 1's has to be set in these two locations. A test is first made for the value "0" in Y. If that value is found, the accumulator is cleared, as well as the carry bit (the carry bit will be used as an indicator for the fact that Y contained the value "9"):

```
LITE      BNE STRTSH      Test Y for zero
          LDA #0
          CLC
          RTS
```

Otherwise, the accumulator is initially cleared, and the appropriate number of 1's is shifted left into the accumulator through the carry bit. They are introduced one at a time by setting the carry bit, then performing a left shift into A. Each time, index register Y is decremented and the loop is executed again as long as Y is not "0":

```
SHIFT      LDA #0
          SEC
          ROL A           Shift into position
          DEY
          BNE SHIFT      Loop
          RTS
```

Note that a rotation to the left is used rather than a shift. If Y did contain the value "9," the accumulator A would be filled with 1's and the carry bit would also contain the value "1" upon leaving the subroutine.

The Interrupt Handler

This subroutine complements the LEDs each time an interrupt is received, i.e., every time timer 1 runs out. It is located at memory addresses "03EA" and following. Since the accumulator is used as a working register by the subroutine, it must be preserved upon entry and pushed into the stack:

```
PHA
```

The contents of Ports 1A and 1B will be read and then complemented. Recall that there is no complementation instruction on the 6502, so an exclusive OR will be used instead. MASKA and MASKB specify the bits to be complemented:

```
LDA PORT1A
EOR MASKA
STA PORT1A
LDA PORT1B
EOR MASKB
STA PORT1B
```

Also recall that the interrupt bit in the 6522 has to be cleared explicitly after every interrupt. This is done by reading the latch:

```
LDA TILL
```

Finally, the accumulator is restored, and a return occurs to the main program:

PLA
RTI

SUMMARY

In this program, we have used two new hardware resources in the 6522 I/O chip: the interrupt control and the programmable interval timer. Interrupts have been used to implement simultaneous processing by blinking the LEDs while the program proceeds, testing for a win or lose situation.

Exercise 9.1: *Could you implement the same without using interrupts?*

```

;MINDBENDER PROGRAM
;PLAYS MINDBENDER GAME: USER SPECIFIES LENGTH OF NUMBER
;TO BE GUESSED, THEN GUESSES DIGITS, AND COMPUTER TELLS
;PLAYER HOW MANY OF THE DIGITS GUESSED WERE RIGHT, AND
;HOW MANY OF THOSE CORRECT DIGITS WERE IN THE CORRECT
;PLACE, UNTIL THE PLAYER CAN GUESS THE NUMBER. ON THE
;BOARD, BLINKING LEDS INDICATE CORRECT VALUE & CORRECT
;DIGIT, AND NONBLINKING LEDS SHOW CORRECT DIGIT VALUE,
;BUT WRONG PLACE.
;THE BOTTOM ROW OF LEDS IS USED TO SHOW THE MODE OF
;THE PROGRAM: IF THE LEFTMOST LED IS LIT, THE
;PROGRAM EXPECTS THE USER TO ENTER THE LENGTH
;OF THE NUMBER TO BE GUESSED. IF THE TWO LEFTMOST
;LEDS ARE LIT, THE PROGRAM EXPECTS A GUESS.
;THE PROGRAM REJECTS UNSUITABLE VALUES FOR A NUMBER
;LENGTH, WHICH CAN ONLY BE 1-9. A VALUE OTHER THAN
;0-9 FOR A GUESS RESTARTS THE GAME.
;A LOW TONE DENOTES A BAD GUESS, A HIGHT TONE, A WIN.
;AFTER A WIN, THE PROGRAM RESTARTS.
;AN INTERRUPT ROUTINE IS USED TO BLINK THE LEDS.
;

      = $200
GETKEY  = $100
ACCESS  = $8886 ;ROUTINE TO UNPROTECT SYS MEM
DIGITS  = $00    ;NUMBER OF DIGITS TO BE GUESSED
DUR     = $01    ;TONE DURATION CONSTANT
XTEMP   = $02    ;TEMP STORAGE FOR X REG.
YTEMP   = $03    ;TEMP STORAGE FOR Y REG.
CNT     = $04    ;KEEPS TRACK OF # OF MATCHES
MASKA   = $05    ;CONTAINS PATTERN EOR'ED WITH LED
          ;STATUS REGISTER A TO CAUSE BLINK
          ;LED PORT B BLINK MASK
MASKB   = $06    ;LED PORT B BLINK MASK
FREQ    = $07    ;TEMP STORAGE FOR TONE FREQUENCY
CNT1    = $08    ;# OF CORRECT DIGITS IN RIGHT PLAC
RND     = $09    ;FIRST OF RANDOM # LOCATIONS
DIGO    = $0F    ;FIRST OF 9 DIGIT LOCATIONS
ENTRYO  = $18    ;FIRST OF 9 GUESS LOCATIONS
IRQVECL = $A67E  ;INTERRUPT VECTOR LOW ORDER BYTE
IRQVECH = $A67F  ;..AND HIGH ORDER
          ;6522 VIA #1 REGISTERS:

```

Fig. 9.13: Mindbender Program

```

IER     = $A00E  ;INTERRUPT ENABLE REGISTER
ACR     = $A00B  ;AUXILIARY CONTROL REGISTER
TILL    = $A004  ;TIMER 1 LATCH LOW
T1CH    = $A005  ;TIMER 1 COUNTER HIGH
PORT1A  = $A001  ;VIA 1 PORT A IN/OUT REG
DDR1A   = $A003  ;VIA 1 PORT A DATA DIRECTION REG.
PORT1B  = $A000  ;VIA 1 PORT B IN/OUT REG
DDR1B   = $A002  ;VIA 1 PORT B DATA DIRECTION REG.
PORT3B  = $AC00  ;VIA 3 PORT B IN/OUT REG
DDR3B   = $AC02  ;VIA 3 PORT B DATA DIRECTION REG
;
;ROUTINE TO SET UP VARIABLES AND INTERRUPT TIMER FOR
;L.E.D. FLASHING
;
0200: 20 86 8B      JSR ACCESS ;UNPROTECT SYSTEM MEMORY
0203: A9 EA        LDA #$EA ;LOAD LOW INTERRUPT VECTOR
0205: 8D 7E A6     STA IRQVECL ;...AND STORE AT VECTOR LOCATION
0208: A9 03        LDA #$03 ;LOAD INTERRUPT VECTOR...
020A: 8D 7F A6     STA IRQVECH ;...AND STORE.
020D: A9 7F        LDA #$7F ;CLEAR INTERRUPT ENABLE REGISTER
020F: 8D 0E A0     STA IER
0212: A9 C0        LDA #$C0 ;ENABLE TIMER 1 INTERRUPT
0214: 8D 0E A0     STA IER
0217: A9 40        LDA #$40 ;ENABLE TIMER 1 IN FREE-RUN MODE
0219: 8D 0B A0     STA ACR
021C: A9 FF        LDA #$FF
021E: 8D 04 A0     STA TILL ;SET LOW LATCH ON TIMER 1
0221: 8D 05 A0     STA T1CH ;SET LATCH HIGH & START COUNT
0224: 58           CLI ;ENABLE INTERRUPTS
0225: 8D 03 A0     STA DDR1A ;SET VIA 1 PORT A FOR OUTPUT
0228: 8D 02 A0     STA DDR1B ;SET VIA 1 PORT B FOR OUTPUT
022B: 8D 02 AC     STA DDR3B ;SET VIA 3 PORT B FOR OUTPUT
022E: A9 00        LDA #0 ;CLEAR LEDS
0230: 8D 01 A0     STA PORT1A
0233: 8D 00 A0     STA PORT1B
0236: 85 05        STA MASKA ;CLEAR BLINK MASKS
0238: 85 06        STA MASKB
;
;ROUTINE TO GET NUMBER OF DIGITS TO GUESS, THEN
;FILL THE DIGITS WITH RANDOM NUMBERS FROM 0-9
;
023A: A9 02        LDA #20000010 ;LIGHT LED TO SIGNAL USER TO
023C: 8D 00 A0     STA PORT1B ;INPUT OF # OF DIGITS NEEDED.
023F: 20 00 01     JSR GETKEY ;GET # OF DIGITS
0242: C9 0A        CMP #10 ;IF KEY# >9, RESTART GAME
0244: 10 E8        BPL KEY1
0246: C9 00        CMP #0 ;CHECK FOR 0 DIGITS TO GUESS
0248: F0 E4        BEQ KEY1 ;...0 DIGITS NOT ALLOWED
024A: 85 00        STA DIGITS ;STORE VALID # OF DIGITS
024C: AD 04 A0     LDA TILL ;GET RANDOM #
024F: 85 0A        STA RND+1 ;USE IT TO START RANDOM
0251: 85 0D        STA RND+4 ;NUMBER GENERATOR.
0253: 85 0E        STA RND+5
0255: A4 00        LDY DIGITS ;GET # OF DIGITS TO BE GUESSED,
0257: 88           DEY ;..AND COUNT TO 0, FILLING
          ;THEM WITH VALUES.
0258: 20 FF 02     JSR RANDOM ;GET RANDOM VALUE FOR DIGIT
025B: F8           SED
025C: 69 00        ADC #00 ;DECIMAL ADJUST
025E: D8           CLD
025F: 29 0F        AND #200001111 ;KEEP DIGIT <10
0261: 99 0F 00     STA DIGO,Y ;SAVE IT IN DIGIT TABLE.
0264: 88           DEY
0265: 10 F1        BPL RAND ;FILL NEXT DIGIT
;

```

Fig. 9.13: Mindbender Program (Continued)

```

;ROUTINE TO FILL GUESS TABLE W/USERS'S GUESSES
;
0267: A9 00 ENTER LDA #0 ;CLEAR ENTRY TABLE POINTER
0269: 85 02 STA XTEMP
026B: A9 06 LDA #200000110 ;LET USER KNOW THAT GUESSES
026D: 0D 00 A0 DRA PORT1B ;SHOULD BE INPUT...
0270: 8D 00 A0 STA PORT1B ;...WITHOUT CHANGING ARRAY
0273: 20 00 01 KEY2 JSR GETKEY ;GET GUESS
0276: C9 0A CMP #10 ;IS IT GREATER THAN 9?
0278: 10 B4 BPL KEY1 ;IF YES, RESTART GAME
027A: A6 02 LDX XTEMP ;GET POINTER FOR INDEXING
027C: 95 18 STA ENTRY0,X ;STORE GUESS IN TABLE
027E: E8 INX ;INCREMENT POINTER
027F: 86 02 STX XTEMP
0281: E4 00 CPX DIGITS ;CORRECT # OF GUESSES FETCHED?
0283: D0 EE BNE KEY2 ;IF NOT, GET ANOTHER
;
;THIS ROUTINE COMPARES USERS'S GUESSES WITH DIGITS
;OF NUMBER TO GUESS. FOR EACH CORRECT DIGIT IN THE
;CORRECT PLACE, A BLINKING LED IS LIT, AND FOR EACH
;CORRECT DIGIT IN THE WRONG PLACE, A NONBLINKING
;LED IS LIT.
;
0285: A2 00 LDX #0 ;CLEAR FOLLOWING STORAGES:
0287: 8E 01 A0 STX PORT1A ;LEDS
028A: 8E 00 A0 STX PORT1B
028D: 86 05 STX MASKA ;BLINK MASKS
028F: 86 06 STX MASKB
0291: 86 04 STX CNT ;COUNT OF MATCHES
0293: 86 08 STX CNT1 ;COUNT OF RIGHT DIGITS
0295: B5 0F DIGLP LDA DIG0,X ;LOAD 1ST DIGIT OF # FOR COMPARES
0297: D5 18 CMP ENTRY0,X ;RIGHT GUESS/RIGHT PLACE?
0299: D0 04 BNE ENTRYCMP ;NO: IS GUESS RIGHT DIGIT/
;WRONG PLACE?
029B: E6 08 INC CNT1 ;ONE MORE RIGHT GUESS/RIGHT PLACE
029D: D0 10 BNE NEXTDIG ;EXAMINE NEXT DIGIT OF NUMBER
029F: A0 00 ENTRYCMP LDY #0 ;RESET GUESS# PTR FOR COMPARES
02A1: D9 18 00 ENTRYLP CMP ENTRY0,Y ;RIGHT DIGIT/WRONG PLACE?
02A4: D0 04 BNE NEXTENT ;NO, SEE IF NEXT DIGIT IS.
02A6: E6 04 INC CNT ;ONE MORE RIGHT DIGIT/WRONG PLACE
02A8: D0 05 BNE NEXTDIG ;EXAMINE NEXT DIGIT OF NUMBER
02AA: C8 NEXTENT INY ;INCREMENT GUESS# PTR
02AB: C4 00 CPY DIGITS ;ALL GUESSES TESTED?
02AD: D0 F2 BNE ENTRYLP ;NO, TRY NEXT GUESS.
02AF: E8 NEXTDIG INX ;INCREMENT DIGIT# PTR
02B0: E4 00 CPX DIGITS ;ALL DIGITS EVALUATED?
02B2: D0 E1 BNE DIGLP ;NO, CHECK NEXT DIGIT.
02B4: 18 CLC ;GET READY FOR ADD...
02B5: A5 04 LDA CNT ;OF TOTAL MATCHES TO DETERMINE
02B7: 65 08 ADC CNT1 ;NUMBER OF LEDS TO LIGHT
02B9: AB TAY ;XFER A TO Y FOR 'LIGHT' ROUTINE.
02BA: 20 F1 02 JSR LITE ;GET PATTERN TO LIGHT LEDS
02BB: 8D 01 A0 STA PORT1A ;TURN LEDS ON
02C0: 90 05 BCC CC ;IF CARRY=0, DON'T LIGHT PBO
02C2: A9 01 LDA #1
02C4: 8D 00 A0 STA PORT1B ;TURN PBO ON.
02C7: A4 08 CC LDY CNT1 ;LOAD # OF LEDS TO BLINK
02C9: 20 F1 02 JSR LITE ;GET PATTERN
02CC: 85 05 STA MASKA ;START TO BLINK LEDS
02CE: 90 04 BCC TEST ;IF CARRY =0, PBO WON'T BLINK
02D0: A9 01 LDA #1
02D2: 85 06 STA MASKB
;
;ROUTINE TO TEST FOR WIN BY CHECKING IF # OF CORRECT

```

Fig. 9.13: Mindbender Program (Continued)

```

;DIGITS IN CORRECT PLACES = NUMBER OF DIGITS. IF WIN,
;A HIGH PITCHED SOUND IS GENERATED, AND IF ANY
;DIGIT IS WRONG, A LOW SOUND IS GENERATED.
;
02D4: A6 08 TEST LDX CNT1 LOAD NUMBER OF CORRECT DIGITS
02D6: E4 00 CPX DIGITS ;ALL GUESSES CORRECT?
02D8: F0 0B BEQ WIN ;IF YES, PLAYER WINS
02DA: A9 72 BAD LDA #72
02DC: 85 01 STA DUR ;SET UP LENGTH OF LOW TONE
02DE: A9 BE LDA #BE ;TONE VALUE FOR LOW TONE
02E0: 20 12 03 JSR TONE ;SIGNAL BAD GUESSES W/TONE
02E3: F0 82 BEQ ENTER ;GET NEXT GUESSES
02E5: A9 FF WIN LDA #FF ;DURATION FOR HIGH TONE
02E7: 85 01 STA DUR
02E9: A9 54 LDA #54 ;TONE VALUE FOR HIGH TONE
02EB: 20 12 03 JSR TONE ;SIGNAL WIN
02EE: 4C 2E 02 JMP KEY1 ;RESTART GAME
;
;ROUTINE TO FILL ACCUMULATOR WITH '1' BITS, STARTING
;AT THE LOW ORDER END, UP TO AND INCLUDING THE
;BIT POSITION CORRESPONDING TO THE # OF LEDS TO
;BE LIT OR SET TO BLINKING.
;
02F1: D0 04 LITE BNE STRTSH ;IF Y NOT ZERO, SHIFT ONES IN
02F3: A9 00 LDA #0 ;SPECIAL CASE: RESULT IS NO ONES.
02F5: 18 CLC
02F6: 60 RTS
02F7: A9 00 STRTSH LDA #0 ;CLEAR A SO PATTERN WILL SHOW
02F9: 38 SHIFT SEC ;MAKE A BIT HIGH
02FA: 2A ROL A ;SHIFT IT TO CORRECT POSITION
02FB: 88 DEY ;BY LOOPING TO # OF GUESS/DIGIT
;MATCHES, AS PASSED IN Y
02FC: D0 FB BNE SHIFT ;LOOP 'TIL DONE
02FE: 60 RTS
;
;RANDOM NUMBER GENERATOR
;USES NUMBERS A,B,C,D,E,F STORED AS RND THROUGH
;RND+5; ADDS B+E+1 AND PLACES RESULT IN A, THEN
;SHIFTS A TO B, B TO C, ETC. THE NEW RANDOM NUMBER
;WHICH IS BETWEEN 0 AND 255 INCLUSIVE IS IN THE
;ACCUMULATOR ON EXIT
;
02FF: 38 RANDOM SEC ;CARRY ADDS VALUE 1
0300: A5 0A LDA RND+1 ;ADD A,B,E AND CARRY
0302: 65 0D ABC RND+4
0304: 65 0E ADC RND+5
0306: 85 09 STA RND
0308: A2 04 LDX #4 ;SHIFT NUMBERS OVER
030A: B5 09 RPL LDA RND,X
030C: 95 0A STA RND+1,X
030E: CA DEX
030F: 10 F9 RPL RPL
0311: 60 RTS
;
;TONE GENERATOR ROUTINE.
;DURATION OF TONE (NUMBER OF CYCLES TO CREATE)
;SHOULD BE IN 'DUR' ON ENTRY, AND THE NOTE VALUE
;(FREQUENCY) IN THE ACCUMULATOR.
;
0312: 85 07 TONE STA FREQ
0314: A9 FF LDA #FF
0316: 8D 00 AC STA PORT3B
0319: A9 00 LDA #00
031B: A6 01 LDX DUR
031D: A4 07 FL2 LDY FREQ

```

Fig. 9.13: Mindbender Program (Continued)

```

031F: 8B      FL1    DEY
0320: 18      CLC
0321: 90 00   BCC ,+2
0323: D0 FA   BNE FL1
0325: 49 FF   EOR #$FF
0327: 8D 00 AC STA PORT3B
032A: CA      DEX
032B: D0 F0   BNE FL2
032D: 60      RTS

;
; INTERRUPT-HANDLING ROUTINE
; COMPLEMENTS LEDS AT EACH INTERRUPT
;
      = $3EA    ;LOCATE ROUTINE IN HIGH MEMORY
03EA: 48      FHA      ;SAVE ACCUMULATOR
03EB: AD 01 A0 LDA PORT1A ;GET PORT FOR COMPLEMENTING
03EE: 45 05   EOR MASKA ;COMPLEMENT NECESSARY BITS
03F0: 8D 01 A0 STA PORT1A ;STORE COMPLEMENTED CONTENTS
03F3: AD 00 A0 LDA PORT1B ;DO SAME WITH PORT1B
03F6: 45 06   EOR MASKB
03F8: 8D 00 A0 STA PORT1B
03FB: AD 04 A0 LDA T1LL  ;CLEAR INTERRUPT BIT IN VIA
03FE: 68      PLA      ;RESTORE ACCUMULATOR
03FF: 40      RTI      ;DONE, RESUME PROGRAM

SYMBOL TABLE:
GETKEY    0100    ACCESS    8B84      DIGITS    0000
DUR       0001    XTEMP    0002      YTEMP    0003
CNT       0004    MASKA    0005      MASKB    0006
FREQ      0007    CNT1     0008      RND       0009
DIGO      000F    ENTRY0   0018      IRQVECL  A67E
IRQVECH   A67F    IER      A00E      ACR       A00B
T1LL      A004    T1CH     A005      PORT1A    A001
DDR1A     A003    PORT1B   A000      DDR1B     A002
PORT3B    AC00    DDR3B    AC02      KEY1      022E
RAND      0258    ENTER    0267      KEY2      0273
DIGLP     0295    ENTRYCMP 029F      ENTRYLP   02A1
NEXTENT   02AA    NEXTDIG  02AF      CC        02C7
TEST      02D4    BAD      02DA      WIN       02E5
LITE      02F1    STRTSH   02F7      SHIFT     02F9
RANDOM     02FF    RPL      030A      TONE      0312
FL2       031D    FL1      031F
DONE

```

Fig. 9.13: Mindbender Program (Continued)

10

BLACKJACK

THE RULES

The standard game of Blackjack or "21," is played in the following way. A player attempts to beat the dealer by acquiring cards which, when their face values are added together, total more points than those in the dealer's hand but not more than a maximum of 21 points. If at any time the total of 21 is achieved after only two cards are played, a win is automatically declared for the player; this is called a Blackjack (the name of the game). Card values range from 1 through 11. In the standard version of Blackjack the house rules require the dealer to "hit" (take a card) if his/her hand equals 16 or fewer points, but prohibits him/her from taking a "hit" when his or her hand totals 17 or more points.

The version of Blackjack played on the Games Board differs slightly from the standard game of Blackjack. The single "deck of cards" used here contains cards with values from 1 through 10 (rather than 1 through 11), and the number of points cannot exceed 13 (as opposed to 21). The dealer in this variation of the game is the computer.

At the beginning of each hand, one card is dealt to the dealer and one to the player. A steady LED on the Games Board represents the value of the card dealt to the dealer (the computer). A flashing LED represents the card dealt to the player. If the player wants to be "hit" (i.e., receive another card) he/she must press key "C." The player may hit several times. However, if the total of the player's cards ever exceeds 13, the player has lost the round ("busted") and he/she can no longer play. It is then the dealer's turn. Similarly, if the player decides to pass ("stay"), it becomes the dealer's turn. The dealer plays in the following manner: if the dealer's hand totals fewer than 10

points, the computer deals itself one more card. As long as the hand does not exceed 13, the computer will check to see if it needs another card. Like the situation with the player, once the total of the computer's cards exceeds 13, it loses. No provision has been made for a bonus or an automatic win, which occurs whenever the player or the dealer gets exactly 13 points with only two cards (a Blackjack). This is left as an exercise for the reader. Once the dealer finishes its turn, assuming that it does not bust, the values of both hands are compared. If the dealer's total is greater than the player's, the player loses. Otherwise, the player wins. At the beginning of each series the player is allocated 5 chips (5 points). Each loss decreases this total by one chip; each win increases it by one. The game is over when the player goes broke and loses, or reaches a score of 10 and wins. After each play the resulting score is displayed as a number between 0 and 10 on the appropriate LED. Each time a player wins a hand, the left-most three LEDs of the bottom row light up. If the dealer wins the hand, the right-most LEDs light up. (See Figure 10.1.)

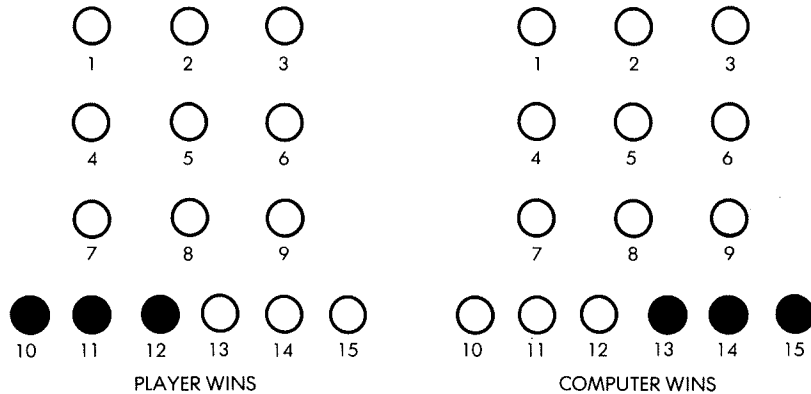

Fig. 10.1: Indicating the Winner

A TYPICAL GAME

When playing a game against the dealer, the player will press key "A" to be "hit" (receive an additional card) until either a total of 13 is exceeded (a "bust"), or until the player decides that his or her total is close enough to 13 that he or she might beat the dealer. When the player makes this decision to stay, he or she must press key "C." This will start the dealer's turn, and all other keys will then be ignored.

LEDs will light up in succession on the board as the computer deals itself additional cards until it goes over ten, reaches 13 exactly, or busts. Once the computer has stopped playing, any key may be pressed; the player's score will be displayed and the winner will be indicated through lit LEDs on the winner's side. The display will appear for approximately one second, then a new hand will be dealt.

Note that once the value of the computer's hand has reached a total greater than or equal to 10, it will do nothing further until a key is pressed. Let us follow this "typical game."

The initial display is shown in Figure 10.2. A steady LED is shown as a black dot, while a blinking LED is shown as a half dot. In the initial hand the computer has dealt itself a 1 and the player a 4. The player presses key "A" and receives an additional card. It is a 9. The situation is shown in Figure 10.3. It's a Blackjack and the player has won. The best the dealer can hope for at this point is to also reach 13.

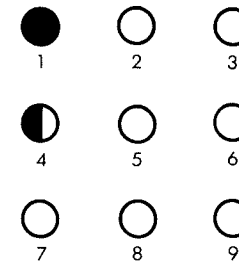

Fig. 10.2: First Hand

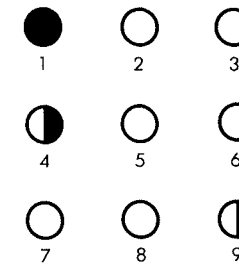

Fig. 10.3: Player Receives A Second Card: Blackjack

Let us examine its response. To do this we must pass by hitting "C." A moment later LED #3 lights up. The total of the computer's hand now is $1 + 3 = 4$. It will deal itself another card. A moment later, LED #7 lights up. The computer's total is now $4 + 7 = 11$. It stops. Having a lower total than the player, it has lost. Let us verify it. We press any key on the keyboard (for example, "0"). The result appears on the display: LEDs 10, 11 and 12 light up indicating a player win, and LED #6 lights up, indicating that the player's score has been increase from 5 to 6 points. This information is shown in Figure 10.4. The

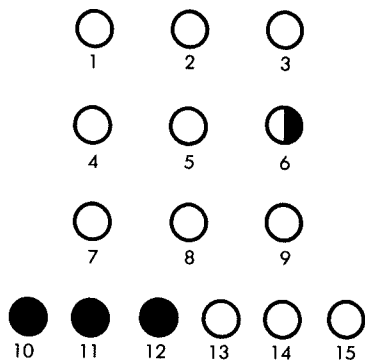

Fig. 10.4: End of Turn: Dealer Loses

LED display then goes blank and a new hand is displayed. When there is a draw, none of the LEDs in the bottom row light up and the score is not changed. A new hand is dealt. (If the player busts, the dealer wins immediately and a computer win is displayed.)

Let us play one more game. At the beginning of this hand the computer has dealt itself a 5, and the player has a 6. The situation is shown in Figure 10.5. Let us ask for another card. We hit key "A" and are given a 7. This is almost unbelievable. We have thirteen again!! The situation is shown in Figure 10.6 It is now the computer's turn. Let us hit "C." LED #10 lights up. The computer has 15. It has busted. The situation is shown in Figure 10.7. Let us verify it. We press any key on the keyboard. The three left-most LEDs on the bottom row (LED 10, 11, and 12) light up and a score of 7 is displayed. This is shown in Figure 10.8. A moment later the display goes blank and a new hand is started.

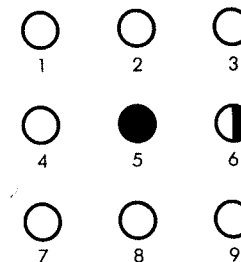

Fig. 10.5: Second Hand

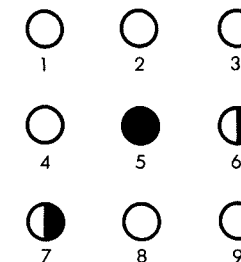

Fig. 10.6: Blackjack Again

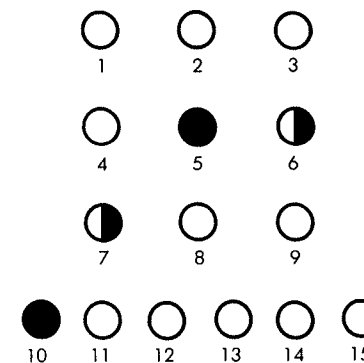

Fig. 10.7: Dealer Busts

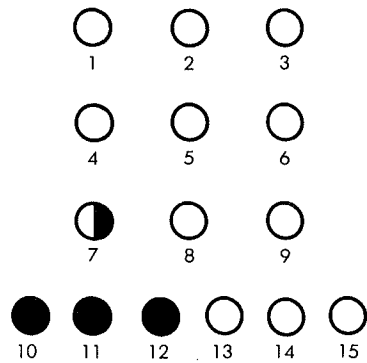

Fig. 10.8: Final Score Is 7

THE PROGRAM

The detailed flowchart for the Blackjack program is shown in Figure 10.9, and the program is listed at the end of the chapter. As usual, a portion of page 0 has been reserved for the variables and flags which cannot be held in the internal registers of the 6502. This area is shown in Figure 10.10 as a "memory map." These variables or flags are:

DONE: This flag is set to the value "0" at the beginning of the game. If the player goes broke, it will be set to the value "11111111." If the player scores 10 (the maximum), it will be set to the value "1." This flag will be tested at the end of the game by the ENDER routine which will display the final result of the game on the board and light up either a solid row of LEDs or a blinking square.

CHIPS: This variable is used to store the player's score. It is initially set to the value "5." Every time the player wins a hand it will be incremented by 1. Likewise, every time the player loses a hand, it will be decremented by 1. The game terminates whenever this variable reaches the value "0" or the value "10."

MASKA, MASKB: These two variables are used to hold the masks or patterns used to blink the LEDs connected respectively to Port A and Port B on the Games Board.

PHAND: It holds the current hand total for the player. It is incremented every time the player hits (i.e., requests an additional card).

CHAND: This variable holds the current hand total for the computer (the dealer).

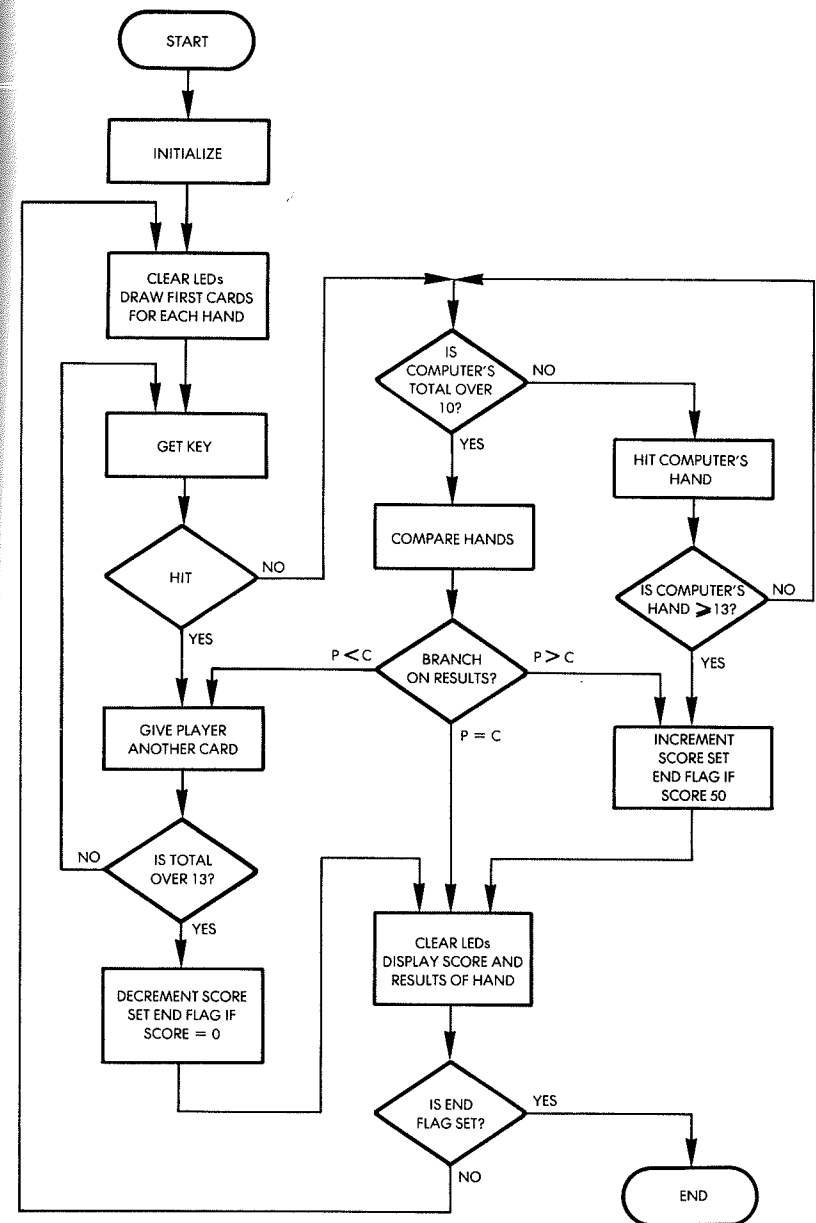

Fig. 10.9: Blackjack Flowchart

TEMP: This is a temporary variable used by the RANDOM routine to deal the next card to either player.

RND through RND + 5: These six locations are reserved for the random number generating routine called RANDER.

WHOWON: This status flag is used to indicate the current winner of the hand. It is initially set to "0," then decremented if the player loses or incremented if the player wins.

At the high end of memory the program uses VIA #1, the ACCESS subroutine provided by the SYM monitor, and the interrupt-vector at address A67E, as shown in Figure 10.11.

Let us now examine the program operation. For clarity it should be followed on the flowchart in Figure 10.9.

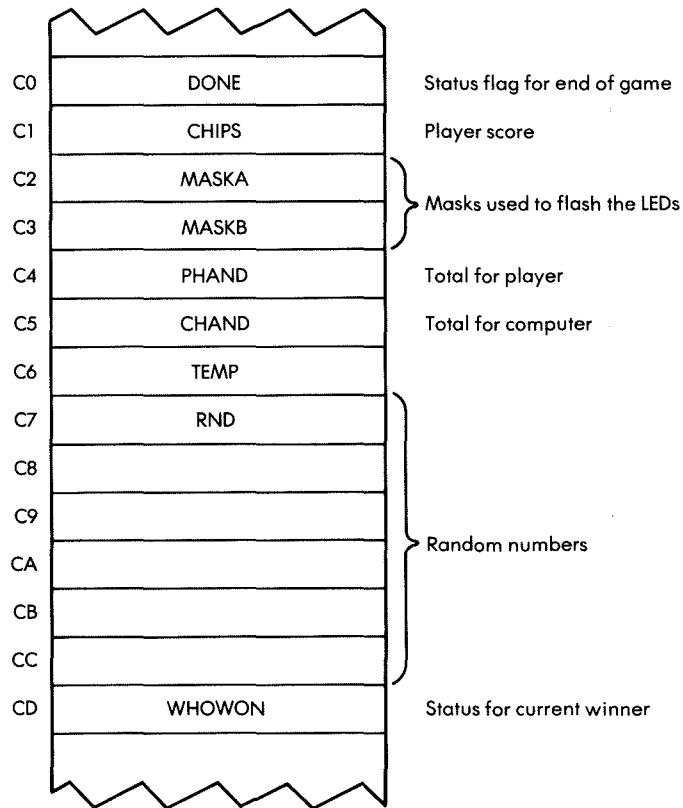

Fig. 10.10: Low Memory Map

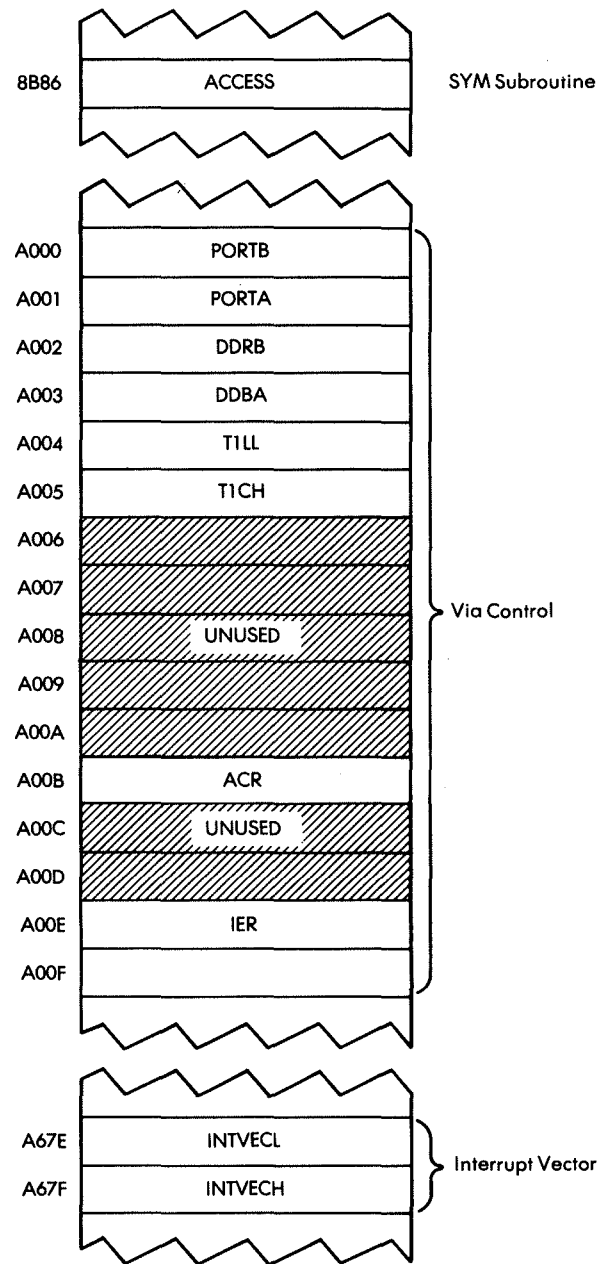

Fig. 10.11: High Memory Map

Program Initialization

The timer on 6522 VIA #1 will be used to generate the interrupts which blink the LEDs. These interrupts will cause a branch to location 03EA where the interrupt-handling routine is located. The first step is, therefore, to load the new value into the interrupt vector, i.e., "03EA," at the appropriate memory location:

| | | |
|--------|-------------|---------------------------|
| BLJACK | JSR ACCESS | Unprotect system memory |
| | LDA #\$EA | Load low interrupt vector |
| | STA INTVECL | |
| | LDA #\$03 | High vector |
| | STA INTVECH | |

As described previously, the interrupt-enable register is first loaded with the value "01111111," and then with the value "11000000" in order to enable the interrupt for timer 1:

| | | |
|--|-----------|------------------------------|
| | LDA #\$7F | Clear timer interrupt-enable |
| | STA IER | |
| | LDA #\$C0 | Enable timer 1 interrupt |
| | STA IER | |

Loading the value "7F" clears bits 0 through 6, thereby disabling all interrupts. Then, loading the value "C0" sets bit 6, which is the interrupt-bit corresponding to timer 1. (See Figure 9.10.) As in the previous chapter, timer 1 is put in the free-running mode. It will then automatically generate interrupts which will be used to blink the LEDs. In order to set it to the free-running mode, bit 6 of the ACR must be set to "1":

| | | |
|--|-----------|------------------|
| | LDA #\$40 | Put timer 1 |
| | STA ACR | In free run mode |

The latches for timer 1 are initialized to the highest possible value, i.e., FFFF:

| | | |
|--|-----------|----------------------------|
| | LDA #\$FF | |
| | STA TILL | Low latch of timer 1 |
| | STA TICH | High latch and start timer |

Finally, now that the timer has been correctly initialized, interrupts are enabled on the processor:

| | |
|-----|-------------------|
| CLI | Enable interrupts |
|-----|-------------------|

LED Ports A and B configured as outputs (remember that the accumulator still contains the value "FF"):

| |
|----------|
| STA DDRA |
| STA DDRB |

As a precaution, the decimal flag is cleared:

| |
|-----|
| CLD |
|-----|

The player's score is initialized to the value 5:

| | |
|-----------|-------------------------|
| LDA #5 | Set player's score to 5 |
| STA CHIPS | |

The DONE flag is initialized to the value "0":

| | |
|----------|-----------------|
| LDA #0 | Clear done flag |
| STA DONE | |

The LEDs on the board are cleared:

| | |
|-----------|------------|
| STA MASKA | |
| STA MASKB | |
| STA PORTA | Clear LEDs |
| STA PORTB | |

And the WHOWON flag is also initialized to "0":

| | |
|------------|------------|
| STA WHOWON | Clear flag |
|------------|------------|

Dealing the First Hand

We are now ready to play. Let us deal one card to both the dealer and the player. The LIGHTR and the BLINKR subroutines will be used for that purpose. Each of these subroutines obtains a random

number and lights the corresponding LED. LIGHTR lights up a steady LED while BLINKR blinks the LED. These two subroutines will be described later. We set one LED blinking for the player:

JSR BLINKR Set random blinking LED

and we save the first total for the current player's hand:

STA PHAND Store player's hand

then we do the same for the computer:

JSR LIGHTR Set random steady LED
STA CHAND Store computer's hand

Hit or Stay?

We will now read the keyboard. If the player presses "A," this indicates a requested hit and one additional card must be dealt to the player. If "C" is pressed, the player "stays" (passes) and it becomes the computer's turn to play. All other keys are ignored. Let us first obtain the key closure from the keyboard:

ASK JSR GETKEY

The key value must now be compared to "A" and to "C":

CMP #\$0A
BEQ HITPLR
CMP #\$0C Is it computer's turn?
BEQ DEALER

If any other key has been pressed, it will be ignored and a new key will be read:

JMP ASK Invalid key, try again

At this point in the program, we will assume the situation warrants a "hit." One more card must be dealt to the player. Let us set one more LED blinking. Naturally, the BLINKR subroutine, as well as the LIGHTR subroutine, are careful not to deal a card that has already

been dealt. How this is achieved will be described later (this is the purpose of the SETBIT subroutine).

HITPLR JSR BLINKR Set random LED

As soon as a new card has been dealt to the player, we compute the player's new total for the current hand:

CLC
ADC PHAND Tally player's hand
STA PHAND

The new total must be checked against the value "13." As long as the player has 13 or less, he or she may play again, i.e., either be hit or stay. However, if the player's score exceeds "13," he or she busts and loses the play. Let us check:

CMP #14 Check for 13
BCC ASK Ask if \leq 13
JMP LOSE Busted

It is now the dealer's turn. Since the computer is much faster than the player in deciding whether it wants to hit or to stay, we will first slow it down to provide more suspense to the game:

DEALER JSR DELAY

The delay subroutine also extends the period of time between the successive decisions made by the computer to make the computer appear more "human-like."

Before dealing another card to the computer (the dealer), let us examine its total. The house rule is that the dealer's total cannot exceed "10." (Naturally, other algorithms are available from Blackjack experts.) The computer hand is therefore checked against the value "10." If this value is exceeded, a branch occurs to location WINNER where the winner will be decided. Otherwise, a new card will be dealt to the computer:

LDA CHAND
CMP #10 Check hand for limit
BCS WINNER Yes. Decide winner.

As long as the hand totals less than "10," the dealer requests a hit. A new card is dealt to the dealer in exactly the same way that it was dealt previously to the player:

JSR LIGHTR Set random LED

The dealer's new total is computed:

CLC
ADC CHAND Tally computer's hand
STA CHAND

Just as in the case of the player before, it is compared against the value "13" to determine whether or not the dealer has busted:

CMP #14 Is hand \leq 13?
BCC DEALER Yes: another hit?
JMP WIN Busted: player wins

If the computer has busted, a jump occurs to location WIN which indicates a "win" by the player. Otherwise, a branch back to location DEALER occurs, where the computer will determine whether or not it wants to receive an additional card. Let us now determine the winner. Both hands are compared:

WINNER LDA CHAND
CMP PHAND Compare hands

There are three possible cases: equal scores, player wins, and player loses.

BEQ SCORER
BCC WIN

In the case that both scores are equal, a jump occurs to location SCORER which will display the current status. If the player wins, a branch occurs to location WIN and the sequence will be described below. First, let us examine what happens when the player loses.

The Player Loses

A special flag, called WHOWON, is used to store the status at the

end of each play. It is decremented to indicate a loss by the player:

LOSE DEC WHOWON

The player's score is decremented:

DEC CHIPS

The player's score must be compared to the value "0." If the player's score has reached "0," he or she is broke and has lost the game. In this case, the DONE flag is set to "11111111;" otherwise, it is not changed. Finally a jump occurs to SCORER where the final score will be displayed:

BNE SCORER Player broke?
DEC DONE Yes: set lose flag
JMP SCORER Finish game

Player Has Won

Similarly, when the player wins, the WHOWON flag is set to "1":

WIN INC WHOWON

The score is incremented:

INC CHIPS

It is then compared to the value "10":

LDA CHIPS
CMP #10 Chips = 10?

If the maximum score of "10" has been reached, the DONE flag is set.

BNE SCORER
INC DONE Set done flag

Displaying the final status is accomplished by the SCORER routine. Remember that the final status will be displayed only at the player's request — when any key is pressed on the keyboard. Let us wait for

this:

```
SCORER    JSR GETKEY
```

Before displaying the status, all LEDs on the board are turned off:

```
LDA #0
STA MASKA
STA MASKB
STA PORTA
STA PORTB
```

The player's score must now be displayed on the board. Let us read it:

```
LDX CHIPS
BEQ ENDER
```

If the player has no more chips, a branch occurs to location ENDER and the game will be terminated. Otherwise, the score is displayed. Unfortunately, LEDs are numbered internally "0" through "7," even though they are labeled externally "1" through "8." In order to light up the proper LED, the score must therefore first be decremented:

```
DEX
```

then a special subroutine called SETMASK is used to display the appropriate LED. On entry to the SETMASK routine, it is assumed that the accumulator contains the number of the LED to be displayed.

```
TXA
JSR SETMASK
```

Now that the proper mask has been created to display the score, we must indicate the winner. If the player won, the three left-most LEDs in the bottom row will be lit; if the computer won, the three right-most LEDs will be lit. If it was a tie, no LEDs will be lit on the bottom row. Let us see who won:

```
LDA WHOWON
BEQ ENDER    Tie: do not change LEDs
BMI SC
```

If the player lost, a branch occurs to address SC. If, on the other hand, the player won, the three left-most LEDs in the bottom row are lit:

```
LDA #$0E    Player won: set left LEDs
JMP SC0
```

If the player lost, the three right-most LEDs are lit:

```
SC          LDA #$B0    Player lost: set right LEDs
```

Contained in the accumulator is the appropriate pattern to light the bottom row of LEDs, and this is sent to the Games Board:

```
SC0         ORA PORTB
            STA PORTB
```

End of a Play

The ENDER routine is used to terminate each play. If the score was neither "0" nor "10," a new hand will be dealt:

```
ENDER      JSR DELAY2
            LDA DONE
            BNE EN0
            JMP START
```

Otherwise, we check the DONE flag for either a player win or a player loss. If the player lost the game, the bottom row of LEDs is lit and the program ends:

```
EN0        BPL EN1      $01: Jump on win condition
            LDA #$BE    Solid row of LEDs
            STA PORTB
            RTS         Return to monitor
```

In the case of a player win, a blinking square is displayed and the program is terminated:

```
EN1        LDA #$FF
            STA MASKA
```

```
LDA #$01
STA MASKB
RTS
```

Subroutines

SETBIT Subroutine

The purpose of this subroutine is to create the pattern required to light a given LED. Upon entering the subroutine, the accumulator contains a number between "0" and "9" which specifies which LED must be lit. Upon exiting the subroutine, the correct bit is positioned in the accumulator. If the logical LED number was greater than "7," the carry bit is set to indicate that output should occur on Port B rather than on Port A. Additionally, Y will contain the external value of the LED to be lit (1 to 10).

Let us examine the subroutine in detail. The LED number is saved in index register Y:

```
SETBIT    TAY          Save logical number
```

It is then compared to the limit value "7."

```
CMP #8
BCC SBO
```

If the value was greater than 7, we subtract 8 from it:

```
SBC #8          Subtract if >7
```

Exercise 10-1: Recall that SBC requires the carry to be set. Is this the case?

Now we can be assured that the number in the accumulator is between "0" and "7." Let us save it in X:

```
SBO          TAX
```

A bit will now be shifted into the correct position of the accumulator. Let us first set the carry to "1":

```
SEC          Prepare to roll
```

We clear the accumulator:

```
LDA #0
```

then we roll in the bit to the correct position:

```
SBLOOP    ROL A
           DEX
           BPL SBLOOP
```

Note that index register X is used as a bit-counter. The accumulator is now correctly conditioned. The external number of the LED to be lit is equal to the initial value which was stored in the accumulator plus one:

```
INY          Make Y the external #
```

If LEDs 9 or 10 must be lit, the carry bit must be set to indicate this fact. Port B will have to be used rather than Port A:

```
CPY #9          Set carry for Port B
RTS
```

Exercise 10-2: Compare this subroutine to the LIGHT subroutine in the previous chapter.

Exercise 10-3: How was the carry set for LED #9 at the end?

LIGHTR Subroutine

This subroutine deals the next card to the dealer (computer). It must obtain a random number, then make sure that this card has not already been dealt, i.e., that it does not correspond to a card which has already been displayed on the board. If it has not already been displayed, the random number can be used as the value of the next card to be dealt. A steady LED will then be lit on the board.

Let us first get a random number:

```
LIGHTR    JSR RANDOM
```

It will be shown below that the RANDOM routine does not just ob-

tain a random number but also makes sure that it does not correspond to a card already used. All we have to do then is position the correct bit in the accumulator and display it. Let us use the SETBIT routine we have just described in order to position the bit in the accumulator:

JSR SETBIT

We must determine whether Port A or Port B must be used. This is done by testing the carry bit which has been conditioned by the SETBIT subroutine:

BCS LLO

We will assume that Port A must be used. The new bit will be added to the display by ORing it into Port A:

```
ORA PORTA
STA PORTA
```

The value of the card must be restored into the accumulator. It had been saved in the Y register by the SETBIT routine:

```
TYA
RTS
```

In case Port B is used, the sequence is identical:

```
LLO      ORA PORTB
          STA PORTB
          TYA          Restore value
          RTS
```

BLINKER Subroutine

This subroutine operates exactly like LIGHTR above except that it sets an LED flashing. Note that it contains the SETMASK subroutine which will set the proper LED flashing and exit with a numerical value of the LED in the accumulator:

```
BLINKR   JSR RANDOM   Get random number
SETMASK  JSR SETBIT
```

```
BCS BLO      Branch if Port B
ORA MASKA
STA MASKA
TYA          Restore value
RTS
BLO         ORA MASKB
           STA MASKB
           TYA
           RTS
```

RANDOM Subroutine

This subroutine will generate a random number between "0" and "9" which has not already been used, i.e., which does not correspond to the internal number of an LED that is already lit on the Games Board. The value of this number will be left in the accumulator upon exit. Let us obtain a random number:

```
RANDOM   JSR RANDER   Get 0-255 number
```

The RANDER subroutine is the usual random number generator which has been described in previous chapters. As usual, we must retain only a number between "0" and "9." We will use a different strategy here by simply rejecting any number greater than "9" and asking for a new random number if this occurs:

```
AND #$0F
CMP #10
BCS RANDOM
```

Exercise 10-4: Can you suggest an alternative method for obtaining a number between "0" and "9"? (Hint: such a method has been described in previous chapters.)

A random number between "0" and "9" has now been obtained. Let us obtain the corresponding bit position which must be lit and save it in location TEMP:

```
JSR SETBIT   Set bit in position
STA TEMP
```

We will now check to see if the corresponding bit is already lit on either

Port A or Port B. Let us first check to see if it is Port A or Port B:

```
BCS RN0          Determine Port A or B
```

Assuming that it is Port A, we must now find which LEDs in Port A are lit. This is done by combining the patterns for the blinking and steady LEDs, which are, respectively, in Mask A and Port A:

```
LDA MASKA
ORA PORTA       Combine Port and Mask
```

Then a check is made to see whether or not the bit we want to turn on is already on:

```
JMP RN1
```

If it is on, we must obtain a new random number between "0" and "9":

```
RN1      AND TEMP
          BNE RANDOM
```

If the bit was not already on, we simply exit with the internal value of the LED in the accumulator:

```
DEY
TYA
RTS
```

Similarly, if an LED on Port B had to be turned on, the sequence is:

```
RN0      LDA MASKB
          ORA PORTB
          AND TEMP
          BNE RANDOM
          DEY
          TYA
          RTS
```

RANDER Subroutine

This subroutine generates a random number between "0" and "255." It has already been described in previous chapters.

DELAY Subroutines

Two delay loops are used by this program: DELAY, which provides approximately a half-second delay and DELAY2, which provides twice this delay or approximately one second. Index registers X and Y are each loaded with the value "FF." A two-level nested loop is then implemented:

```
DELAY2      JSR DELAY
DELAY       LDA #$FF
           TAY
D0          TAX
D1          DEX
           LDA #$FF
           BNE D1
           DEY
           BNE D0
           RTS
```

Exercise 10-5: Compute the exact duration of the DELAY subroutines.

Interrupt Handler

The interrupt routine is used to blink LEDs on the board, using MASKA and MASKB, every time that the timer generates an interrupt. No registers are changed. The operation of this routine has been described in the preceding chapter:

```
PHA
LDA PORTA
EOR MASKA
STA PORTA
LDA PORTB
EOR MASKB
STA PORTB
LDA TILL
PLA
RTI
```

SUMMARY

This program was more complex than most, despite the simple strategy

used by the dealer. Most of the logical steps of the algorithm were accompanied by sound and light effects. Note how little memory is required to play an apparently complex game.

Exercise 10-6: Note that this program assumes that the contents of memory location RND are reasonably random at the beginning of the game. If you would like to have a more random value in RND at the beginning of the game, can you suggest an additional instruction to be placed in the initialization phase of this program? (Hint: this has been done in previous programs.)

Exercise 10-7: In the ENDER routine are the instructions "BNE ENO" and "JMP START" both needed? If they are not, under what conditions would they be needed?

Exercise 10-8: "Recursion" describes a routine which calls itself. Is DELAY 2 recursive?

```

; --- BLJACK PROGRAM ---
ACCESS = $B886
INTVECL = $A67E
INTVECH = $A67F
IER = $A00E
ACR = $A00B
TILL = $A004
TICH = $A005
DDRA = $A003
DDRB = $A002
PORTA = $A001
PORTB = $A000
MASKA = $C2
MASKB = $C3
CHIPS = $C1
DONE = $C0
PHAND = $C4
CHAND = $C5
TEMP = $C6
RND = $C7
WHOWON = $CD
GETKEY = $100
. = $200

;
;BLACKJACK GAME: USES A 'DECK' OF 10 CARDS, CARDS DEALT
;TO THE PLAYER ARE FLASHING LED'S, ONES IN THE COM-
;PUTER'S HAND ARE STEADY. CARDS ARE DEALT BY A RANDOM
;NUMBER GENERATOR WHICH IS NON-REPETITIVE. NUMERICAL
;TOTALS ARE KEPT IN ZERO PAGE LOCATIONS 'PHAND' AND
;'CHAND'. PORTA AND PORTB ARE THE OUTPUT PORTS TO THE
;LED DISPLAY, MASKA AND MASKB ARE USED BY THE INTERRUPT
;ROUTINE TO FLASH SELECTED LED'S. 'DONE' AND
;'WHOWON' ARE STATUS FLAGS TO DETERMINE END OF GAME AND
;WHO WON THE CURRENT HAND.

```

Fig. 10.12: Blackjack Program

```

;
; PROGRAM STARTS BY INITIALIZING THE TIMER AND THE
; INTERRUPT VECTOR, THE OUTPUT PORTS ARE TURNED ON,
; AND THE STATUS FLAGS ARE CLEARED.
;
0200: 20 86 8B BLJACK JSR ACCESS ;UNPROTECT SYSTEM MEMORY
0203: A9 EA LDA #EA ;LOAD LOW INTERRUPT VECTOR
0205: 8D 7E A6 STA INTVECL
0208: A9 03 LDA #03 ;LOAD HIGH INTERRUPT VECTOR
020A: 8D 7F A6 STA INTVECH
020D: A9 7F LDA #7F ;CLEAR TIMER INTERRUPT ENABLE
020F: 8D 0E A0 STA IER
0212: A9 C0 LDA #C0 ;ENABLE TIMER 1 INTERRUPT
0214: 8D 0E A0 STA IER
0217: A9 40 LDA #40 ;PUT TIMER 1 IN FREE RUN MODE
0219: 8D 0B A0 STA ACR
021C: A9 FF LDA #FF
021E: 8D 04 A0 STA TILL ;SET LOW LATCH ON TIMER 1
0221: 8D 05 A0 STA TICH ;SET HIGH LATCH & START TIMER
0224: 58 CLI ;ENABLE PROCESSOR INTERRUPTS
0225: 8D 03 A0 STA DDRA ;SET LED PORTS TO OUTPUTS
0228: 8D 02 A0 STA DDRB
022B: D8 CLD
022C: A9 05 LDA #5 ;SET PLAYER'S SCORE TO 5
022E: 85 C1 STA CHIPS
0230: A9 00 LDA #0 ;CLEAR DONE FLAG
0232: 85 C0 STA DONE
;
;NEW HAND: DISPLAY IS CLEARED, BOTH HANDS ARE
;ARE SET WITH START VALUES, AND THE CORRESPONDING
;LED'S ARE SET.
;
0234: 85 C2 START STA MASKA ;CLEAR BLINKER MASKS; IT IS
0236: 85 C3 STA MASKB ;ASSUMED THAT ACC. CONTAINS ZERO
0238: 8D 01 A0 STA PORTA ;CLEAR LED'S
023B: 8D 00 A0 STA PORTB
023E: 85 CD STA WHOWON ;CLEAR FLAG FOR HAND
0240: 20 0F 03 JSR BLINKR ;SET RANDOM BLINKING LED
0243: 85 C4 STA PHAND ;STORE PLAYER'S HAND
0245: 20 F7 02 JSR LIGHTR ;SET A STEADY RANDOM LED
0248: 85 C5 STA CHAND ;STORE COMPUTER'S HAND
;
;KEY INPUT: 'A' IS A HIT, 'C' IS COMPUTER' TURN
;ALL OTHERS ARE IGNORED
;
024A: 20 00 01 ASK JSR GETKEY ;GET A KEY INPUT
024D: C9 0A CMP #0A ;DOES PLAYER WANT A HIT?
024F: F0 07 BEQ HITPLR ;YES, BRANCH
0251: C9 0C CMP #0C ;IS IT 'COMP TURN' KEY?
0253: F0 12 BEQ DEALER ;YES
0255: 4C 4A 02 JMP ASK ;BAD KEY, TRY AGAIN
;
0258: 20 0F 03 HITPLR JSR BLINKR ;SET A RANDOM LED
025B: 18 CLC
025C: 65 C4 ADC PHAND ;TALLY PLAYER'S HAND
025E: 85 C4 STA PHAND
0260: C9 0E CMP #14 ;CHECK HAND
0262: 90 E6 BCC ASK ;IS <=13, OK
0264: 4C 87 02 JMP LOSE ;BUSTED, GO TO LOSE ROUTINE
;
0267: 20 5D 03 DEALER JSR DELAY ;DELAY EXECUTION OF ROUTINE
026A: A5 C5 LDA CHAND ;IS COMP OVER HOUSE LIMIT?
026C: C9 0A CMP #10
026E: 80 0F BCS WINNER ;YES, FIGURE WINNER
0270: 20 F7 02 JSR LIGHTR ;NO,SET RANDOM LED
0273: 18 CLC

```

Fig. 10.12: Blackjack Program (Continued)

```

0274: 65 C5      ADC CHAND    †TALLY COMPUTER'S HAND
0276: 85 C5      STA CHAND
0278: C9 0E      CMP #14     †IS HAND <=13?
027A: 90 EB      BCC DEALER †YES, ANOTHER HIT?
027C: 4C 92 02   JMP WIN     †BUSTED, PLAYER WINS
;
;FIGURE WINNER: 'WIN' AND 'LOSE' TALLY SCORE,
;AND DETERMINE IF THE PLAYER HAS WON OR LOST
;THE GAME. THE 'WHOWON' FLAG IS SET TO SHOW WHO
;WON THE PARTICULAR HAND. IF THE HANDS ARE EQUAL,
;NOTHING IS AFFECTED.
;
027F: A5 C5      WINNER LDA CHAND    †COMPARE HANDS
0281: C5 C4      CMP PHAND
0283: F0 19      BEQ SCORER †ARE EQUAL, NO CHANGE
0285: 90 0B      BCC WIN     †PLAYER'S HAND GREATER
0287: C6 CD      LOSE  DEC WHOWON †LOSE ROUTINE
0289: C6 C1      DEC CHIPS   †TALLY SCORE
028B: D0 11      BNE SCORER †IS PLAYER BROKE?
028D: C6 C0      DEC DONE    †YES, SET END OF GAME FLAG: LOSE
028F: 4C 9E 02   JMP SCORER
0292: E6 CD      WIN  INC WHOWON †WIN ROUTINE
0294: E6 C1      INC CHIPS   †TALLY SCORE
0296: A5 C1      LDA CHIPS   †ADD WINNINGS
0298: C9 0A      CMP #10     †IF CHIPS=10, SET END OF GAME FLAG
029A: D0 02      BNE SCORER
029C: E6 C0      INC DONE    †SET END OF GAME FLAG: WIN
;
;DISPLAY SCORE BY LIGHTING 1 OF 10 LED'S. THE
;BOTTOM ROW OF LED'S IS SET TO SHOW WHETHER THE PLAYER
;FOR THE COMPUTER WON THE HAND. THE DISPLAY IS HELD
;THUS, THEN A TEST IS MADE FOR AN END OF GAME CONDITION
;IF SUCH A CONDITION EXISTS, THE LED'S ARE
;SET ACCORDINGLY, AND THE PROGRAM IS TERMINATED.
;IT IS ASSUMED THAT THE ADDRESS OF THE MONITOR IS
;ON THE STACK.
;
029E: 20 00 01   SCORER JSR GETKEY †HOLD LAST STANDINGS OF CARDS
02A1: A9 00      LDA #0      †CLEAR LED'S
02A3: 85 C2      STA MASKA
02A5: 85 C3      STA MASKB
02A7: 8D 01 A0   STA PORTA
02AA: 8D 00 A0   STA PORTB
02AD: A6 C1      LDX CHIPS   †DISPLAY NUMBER OF CHIPS
02AF: F0 18      BEQ ENDER   †ADJUST SO SUBROUTINE SETS
02B1: CA         DEX         †THE RIGHT LED
02B2: 8A         TXA
02B3: 20 12 03   JSR SETMASK
;
02B6: A5 CD      LDA WHOWON †SEE WHO WON HAND
02B8: F0 0F      BEQ ENDER †TIE- DO NOT AFFECT LED'S
02BA: 30 05      BMI SC
02BC: A9 0E      LDA #0E     †PLAYER WON- SET THREE LEFT LED'S
02BE: 4C C3 02   JMP SC0
02C1: A9 B0      SC  LDA #B0 †PLAYER LOST- SET THREE RIGHT LED'
02C3: 0D 00 A0   SC0 ORA PORTB †SET LED PORT
02C6: 8D 00 A0   STA PORTB
02C9: 20 5A 03   ENDER JSR DELAY2 †HOLD DISPLAY
;
02CC: A5 C0      LDA DONE    †CHECK FOR END OF GAME CONDITION
02CE: D0 03      BNE ENO
02D0: 4C 34 02   JMP START †ZERO, START NEW HAND
02D3: 10 06      ENO  BPL EN1 †#01, WIN CONDITION
02D5: A9 BE      LDA #BE     †SET SOLID ROW LEDS
02D7: 8D 00 A0   STA PORTB
02DA: 60         RTS         †RETURN TO MONITOR

```

Fig. 10.12: Blackjack Program (Continued)

```

02DB: A9 FF      EN1  LDA #FF   †SET BLINKING SQUARE
02DD: 85 C2      STA MASKA
02DF: A9 01      LDA #01
02E1: 85 C3      STA MASKB
02E3: 60         RTS         †RETURN TO MONITOR
;
;
; ---SUBROUTINES---
;
;SET A BIT IN ACCUMULATOR: ENTER WITH A LOGICAL VALUE,
;I.E. 0-9, IN ACC. EXITS WITH A NUMERICAL VALUE(1-10)
;IN Y, AND THE BIT POSITIONED IN ACC. THE CARRY FLAG
;
02E4: A8         SETBIT TAY     †SAVE LOGICAL NUMBER
02E5: C9 08      CMP #8       †BRACKET 0-7 VALUE
02E7: 90 02      BCC SB0
02E9: E9 08      SBC #8       †...SUBTRACT IF >7
02EB: AA         SB0  TAX       †SET INDEX REG
02EC: 38         SEC         †PREPARE BIT TO ROLL
02ED: A9 00      LDA #0
02EF: 2A         SBLOOP ROL A    †MOVE BIT TO POSITION
02F0: CA         DEX
02F1: 10 FC      BPL SBLOOP
02F3: C8         INY         †MAKE Y NUMERICAL, NOT LOGICAL
02F4: C0 09      CPY #9       †SET CARRY. FOR PORTB, C=1
02F6: 60         RTS
;
;LIGHTR: SETS A RANDOM STEADY LED THAT HAS NOT BEEN
;PREVIOUSLY SET. IT GETS A RANDOM NUMBER, THEN SETS
;THE BIT IN THE PROPER PORT. THE NUMERICAL VALUE OF
;BIT SET IS IN THE ACCUMULATOR ON EXIT.
;
02F7: 20 23 03   LIGHTR JSR RANDOM †GET RANDOM NUMBER
02FA: 20 E4 02   JSR SETBIT †GET BIT POSITIONED IN ACC.
02FD: B0 08      BCS LLO     †BRANCH IF PORT B DESIGNATED
02FF: 0D 01 A0   ORA PORTA †SET LED IN PORTA
0302: 8D 01 A0   STA PORTA
0305: 98         TYA
0306: 60         RTS         †RESTORE NUMERICAL VALUE
0307: 0D 00 A0   LLO  ORA PORTB †SET LED IN PORTB
030A: 8D 00 A0   STA PORTB
030D: 98         TYA
030E: 60         RTS         †RESTORE NUMERICAL VALUE
;
;BLINKR: SETS A RANDOM FLASHING LED THAT HAS NOT BEEN
;PREVIOUSLY SET. THE NUMERICAL VALUE OF THE LED IS IN
;THE ACCUMULATOR ON EXIT. IT GETS A RANDOM NUMBER,
;THEN DROPS INTO THE SETMASK ROUTINE TO FLASH THE
;PROPER LED.
;
;SETMASK: ENTER WITH A LOGICAL VALUE, AND ROUTINE
;SETS THE PROPER FLASHING LED. EXITS WITH NUMERICAL
;VALUE OF LED SET IN ACCUMULATOR
;
030F: 20 23 03   BLINKR JSR RANDOM †GET RANDOM NUMBER
0312: 20 E4 02   SETMASK JSR SETBIT
0315: B0 06      BCS BLO     †BRANCH IF PORTB DESIGNATED
0317: 05 C2      ORA MASKA †SET MASKA
0319: 85 C2      STA MASKA
031B: 98         TYA
031C: 60         RTS         †RESTORE NUMERICAL VALUE
031D: 05 C3      BLO  ORA MASKB †SET MASKB
031F: 85 C3      STA MASKB

```

Fig. 10.12: Blackjack Program (Continued)

```

0321: 98          TYA
0322: 60          RTS
;
;GENERATES A RANDOM NUMBER FROM 0 TO 9 THAT IS NOT
;THE NUMBER OF AN LED ALREADY SET. RESULT IS IN ACC ON
;EXIT.
;
0323: 20 47 03  RANDOM JSR RANDEF ;GET 0-255 NUMBER
0326: 29 0F          AND #*0F ;MASK HIGH NIBBLE
0328: C9 0A          CMP #10 ;BRACKET 0-9
032A: B0 F7          BCS RANDOM
032C: 20 E4 02      JSR SETBIT ;SET BIT IN POSITION
032F: 85 C6          STA TEMP ;SAVE IT
0331: B0 08          BCS RNO ;DETERMINE PORT A OR B
0333: A5 C2          LDA MASKA ;COMBINE PORT AND MASK
0335: 0D 01 A0      ORA PORTA
0338: 4C 40 03      JMP RN1
033B: A5 C3          RNO LDA MASKB ;COMBINE PORT AND MASK
033D: 0D 00 A0      ORA PORTB
0340: 25 C6          RN1 AND TEMP ;LOOK AT SPECIFIC BIT
0342: D0 DF          BNE RANDOM ;IF BIT SET ALREADY, TRY AGAIN
0344: 88            DEY ;MAKE Y LOGICAL
0345: 98            TYA ;EXIT WITH VALUE IN ACCUMULATOR
0346: 60            RTS
;
;GENERATES A RANDOM NUMBER FROM 0-255. USES NUMBERS
;A,B,C,D,E,F STORED AS RND THROUGH RND+5. ADDS B+E+F+1
;AND PUTS RESULT IN A, THEN SHIFTS A TO B, B TO C, ETC.
;RANDOM NUMBER IS IN ACCUMULATOR ON EXIT.
;
0347: 38            RANDEF SEC ;CARRY ADDS 1
0348: A5 C8          LDA RND+1 ;ADD B,D,F
034A: 65 CB          ADC RND+4
034C: 65 CC          ADC RND+5
034E: 85 C7          STA RND
0350: A2 04          RDLDEF LDX #4 ;SHIFT NUMBERS DOWN
0352: B5 C7          RDLDEF LDA RND,X
0354: 95 C8          STA RND+1,X
0356: CA            DEX
0357: 10 F9          BPL RDLDEF
0359: 60            RTS
;
;DELAY LOOP: DELAY2 IS SIMPLY TWICE THE TIME DELAY
;OF DELAY. GIVEN LOOP IS APPROX. .5 SEC. DELAY.
;
035A: 20 5D 03      DELAY2 JSR DELAY
035D: A9 FF          DELAY LDA #*FF ;SET VALUE FOR LOOPS
035F: A8            TAY
0360: AA            DO TAX
0361: CA            D1 DEX
0362: A9 FF          LDA #*FF
0364: D0 FB          BNE D1
0366: 88            DEY
0367: D0 F7          BNE DO
0369: 60            RTS
;
;
;INTERRUPT ROUTINE: EXCLUSIVE OR'S THE OUTPUT
;PORTS WITH THE CORRESPONDING BLINKER MASKS EVERY
;TIME THE TIMER TIMES OUT TO FLASH SELECTED LED'S.
;NO REGISTERS ARE CHANGED, AND THE INTERRUPT
;FLAG IS CLEARED BEFORE EXIT.
;
;
03EA: 48            =*03EA
03EB: AD 01 A0      PHA ;SAVE ACCUMULATOR
03EB: AD 01 A0      LDA PORTA ;COMPLEMENT PORTS WITH MASKS

```

Fig. 10.12: Blackjack Program (Continued)

```

03EE: 45 C2          EOR MASKA
03F0: 8D 01 A0      STA PORTA
03F3: AD 00 A0      LDA PORTB
03F6: 45 C3          EOR MASKB
03F8: 8D 00 A0      STA PORTB
03FB: AD 04 A0      LDA TILL ;CLEAR TIMER INTERRUPT BIT
03FE: 68            PLA ;RESTORE ACCUMULATOR
03FF: 40            RTI

```

SYMBOL TABLE:

| | | | | | |
|--------|------|---------|------|---------|------|
| ACCESS | 8886 | INTVECL | A67E | INTVECH | A67F |
| IER | A00E | ACR | A00B | TILL | A004 |
| TICH | A005 | DDRA | A003 | IDRB | A002 |
| PORTA | A001 | PORTB | A000 | MASKA | 00C2 |
| MASKB | 00C3 | CHIPS | 00C1 | DONE | 00C0 |
| PHAND | 00C4 | CHAND | 00C5 | TEMP | 00C6 |
| RND | 00C7 | WHOWON | 00CD | GETKEY | 0100 |
| BLJACK | 0200 | START | 0234 | ASK | 024A |
| HITPLR | 0258 | DEALER | 0267 | WINNER | 027F |
| LOSE | 0287 | WIN | 0292 | SCORER | 029E |
| SC | 02C1 | SCO | 02C3 | ENDER | 02C9 |
| ENO | 02D3 | EN1 | 02DB | SETBIT | 02E4 |
| SBO | 02EB | SBLDEF | 02EF | LIGHTR | 02F7 |
| LLO | 0307 | BLINKR | 030F | SETMASK | 0312 |
| BLO | 031D | RANDOM | 0323 | RNO | 033B |
| RN1 | 0340 | RANDEF | 0347 | RDLDEF | 0352 |
| DELAY2 | 035A | DELAY | 035D | DO | 0360 |
| D1 | 0361 | | | | |

Z

Fig. 10.12: Blackjack Program (Continued)

11

TIC-TAC-TOE

THE RULES

Tic-Tac-Toe is played on a three-by-three sectioned square. An "O" symbol will be used to represent a move by the player and an "X" will be used to display a move by the computer. Each player moves in turn, and on every turn each player strategically places his or her symbol in a chosen section of the board. The first player to line up three symbols in a row (either horizontally, vertically or diagonally) is the winner. An example of the eight possible winning combinations is shown in Figure 11.1. Using our LED display, a continuously lit LED will be used to display an "X," i.e., a computer move. A blinking LED will be used to display an "O," i.e., the player's move.

Either the player or the computer may make the first move. If the player decides to move first, he or she must press key "F." If the computer is to move first, any other key should be pressed and the computer will start the game. At the end of each game a new game will start automatically. The computer is equipped with a variable IQ (intelligence) level ranging from one to fifteen. Every time the computer wins, its IQ level is reduced one unit. Every time the player wins, the computer's IQ level is increased by one unit. This way, every player has a chance to win. A high tone is sounded every time the player wins and a low tone is sounded every time that the player loses.

A TYPICAL GAME

The display is initially blank. We will let the computer start. We do this by pressing any key but the key "F." (If we press key "F," then the player must go first.) Let us begin by pressing "0." After a short pause the computer responds with a "chirp" and makes its move. (See Figure 11.2.)

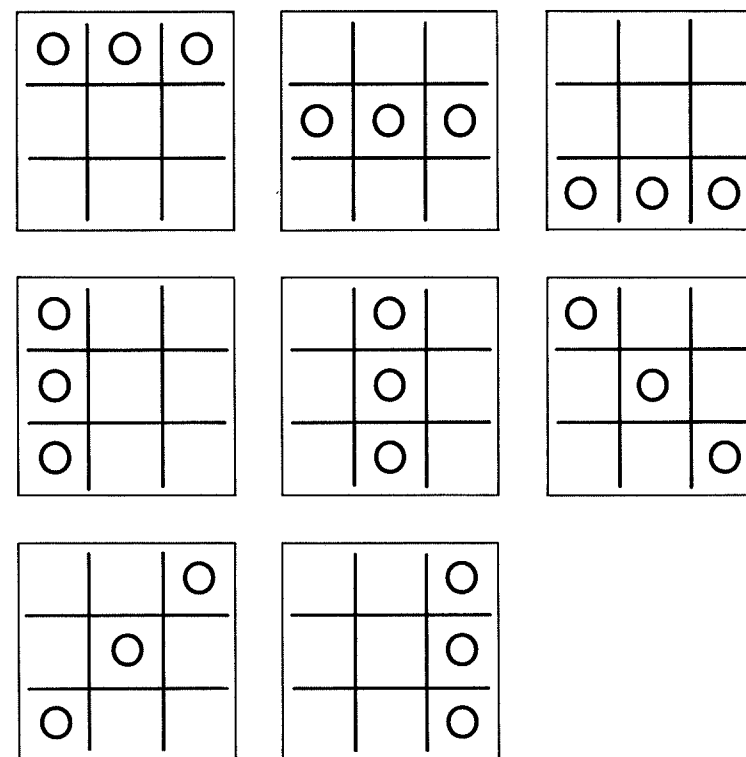

Fig. 11.1: Tic-Tac-Toe Winning Combinations For a Player

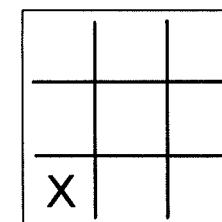

Fig. 11.2: First Computer Move

An "X" is used to denote the computer's moves. "O" will be used to denote our moves. Blank spaces are used to show unlit LEDs. Let

us move to the center and occupy position 5. (See Figure 11.3.) We press key "5." A moment later, LED #1 lights up and a chirp is heard that indicates it is our turn to play. The board is shown in Figure 11.4.

| | | |
|--|---|--|
| | | |
| | O | |
| | X | |

Fig. 11.3: Our First Move

| | | |
|---|---|--|
| X | | |
| | O | |
| X | | |

Fig. 11.4: Second Computer Move

It is now our turn and we should block the computer to prevent it from completing a winning column: let us occupy position 4. We press key "4." A moment later, LED #6 lights up and a chirp is heard. The situation is shown in Figure 11.5.

| | | |
|---|---|---|
| X | | |
| O | O | X |
| X | | |

Fig. 11.5: After the Computer's Third Move

We play in position 2. The computer reacts by playing in position 8. This is shown in Figure 11.6. We prevent the computer from completing a winning row by playing in position 9. The computer responds by occupying position 3. This is shown in Figure 11.7. This is a draw situation. Nobody wins, all the LEDs on the board blink for a moment, and then the board goes blank. We can start another game.

| | | |
|---|---|---|
| X | O | |
| O | O | X |
| X | X | |

Fig. 11.6: After the Computer's Fourth Move

| | | |
|---|---|---|
| X | O | X |
| O | O | X |
| X | X | O |

(DRAW)

Fig. 11.7: After the Computer's Fifth Move

Another Game

This time we are going to start and, hopefully, win! We press "F" to start the game. A chirp is heard, confirming that it is our turn to play. We play in position 5. The computer responds by occupying square 3. The chirp is heard, announcing that we can play again. The situation is shown in Figure 11.8. We play in position 4. The computer responds by occupying square 6. This is shown in Figure 11.9. This time we must block the computer from completing the column on the

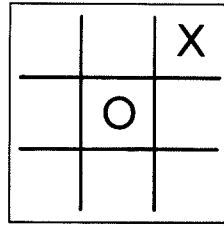

Fig. 11.8: Move 1

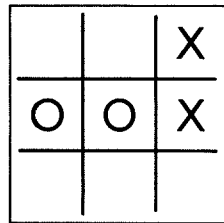

Fig. 11.9: Move 2

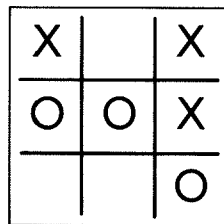

Fig. 11.10: Move 3

right and we move into position 9. The computer responds by moving to square 1, thus preventing us from completing a diagonal. This situation is shown in Figure 11.10. We must prevent the computer from completing a winning row on top; therefore we occupy position 2. The computer responds by occupying position 8. This is shown in Figure 11.11. We make our final move to square 7 to finish the game. This is a draw: we did not beat the computer.

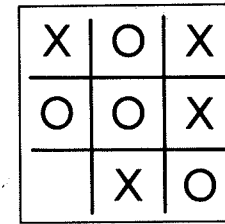

Fig. 11.11: Move 4

Since the computer was “smart enough” to move into a diagonal position after we occupied the center position, we did not win. Note: if we keep trying, at some point the computer will play one of the side positions (2, 4, 6, or 8) rather than one of the corners and we will then have our chance to win. Here is an example.

We move to the center. The computer replies by moving into position 6. The situation is shown in Figure 11.12. We move to square 1; the computer moves to square 9. This is shown in Figure 11.13. We

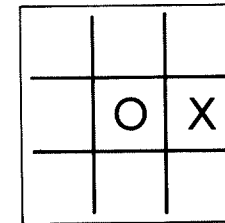

Fig. 11.12: Move 1

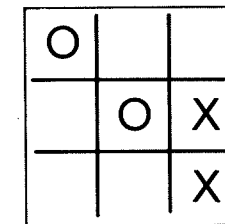

Fig. 11.13: Move 2

move to square 3; the computer moves to square 7. This is shown in Figure 11.14. This time we make the winning move by playing into square 2. The situation is shown in Figure 11.15. Note that if we start playing and if we play well, the result will be either a draw or a win. With Tic-Tac-Toe, the player who starts the game cannot lose if he or she makes no mistakes.

| | | |
|---|---|---|
| O | | O |
| | O | X |
| X | | X |

Fig. 11.14: Move 3

| | | |
|---|---|---|
| O | O | O |
| | O | X |
| X | | X |

Fig. 11.15: "We Win!"

THE ALGORITHM

The algorithm for the Tic-Tac-Toe program is the most complex of those we have had to devise so far. It belongs to the domain of so-called "artificial intelligence." This is a term used to denote the fact that the functions performed by the program duplicate the mental activity commonly called "intelligence." Designing a good algorithm for this game in a small amount of memory space is not a trivial problem. Historically, many algorithms have been proposed, and more can be found. Here, we will examine two strategies in detail, and then select and implement one of them. Additional exercises will suggest other possible strategies.

Strategy to Decide the Next Move

A number of strategies may be used to determine the next move to be made by the computer. The most straightforward approach would be to store all possible patterns and, the best response in each case. This is the best method to use from a mathematical point of view as it guarantees that the best possible move will be made every time. It is also a practical approach because the number of combinations on a 3×3 board is limited. However, since we have already learned to do table lookups for other games, such an approach would not teach us as much about programming. It might also not be considered "fair." We will, therefore, investigate other methods applicable to a wider number of games, or to a larger board.

Many strategies can be proposed. For example, it is possible to consider a *heuristic* strategy in which the computer *learns by doing*. In other words, the computer becomes a better player as it plays more games and learns from the mistakes it makes. With this strategy the moves made by the computer are random at the beginning of the game. However, provided that a sufficient amount of memory is available, the computer remembers every move that it has made. If it is led into a losing situation, the moves leading to it are thrown out by the computer as misjudged moves, and they will not be used again in that sequence. With time and a reasonable "learning" algorithm this approach will result in the construction of *decision tables*. However, this approach assumes that a very large amount of memory is available. This is not the case here. We want to design a program which will fit into 1K of memory. Let us look at another approach.

Another basic approach consists of *evaluating the board* after each move. The board should be examined from two standpoints: first, if there are two "O's" in a row, it is important to block them unless a win can be achieved with the current move. Also, the *win potential* of every board configuration should be examined each time: for example, if two "X's" are in a row, then the program must make a move in order to complete the row for a win. Naturally these two situations are easy to detect. The real problem lies in evaluating the potential of every square on the board in every situation.

An Analytical Algorithm

At this point, we will show the process used to design an algorithm along very general guidelines. After that, as we discover the weaknesses of the algorithm, we will improve upon it. This will serve as an ex-

ample of a possible approach to problem-solving in a game of strategy.

General Concept

The basic concept is to evaluate the potential of every square on the board from two standpoints: "win" and "threat." The *win potential* corresponds to the expectation of winning by playing into a particular square. The *threat potential* is the win potential for the opponent.

We must first devise a way to assign a numerical value to the combinations of "O's and "X's on the board. This must be done so that we can compute the strategic value, or "potential," of a given square.

Value Computation

For each row (or column or diagonal), four possible configurations may occur — that is, if we exclude the case in which all three positions are already taken and we cannot play in a row. These configurations are shown in Figure 11.16. Situation "A" corresponds to the case in which all three squares are empty. Clearly, the situation has some possibilities and we will start by assigning the value "one" to each square in that case. The next case is shown in row "B" of Figure 11.16; it corresponds to the situation in which there is already an "X" in that row. If we were to place a second "X" in that row, we would be very close to a win. This is a desirable situation that has greater value than the preceding one. Let us add "one" to the value of each free square because of the presence of the "X"; the value of each square in that instance will be "two."

Let us now consider case "C" in Figure 11.16, in which we have one "X" and one "O." The configuration has no value since we will never be able to win in that particular row. The presence of an "O" brings the value of the remaining square down to "zero."

Finally, let us examine the situation of row "D" in Figure 11.16, where there are already two "X's. Clearly, this is a winning situation and it should have the highest value. Let us give it the value "three."

The next concept is that each square on the board belongs to a row, a column, and possibly a diagonal. Each square should, therefore, be evaluated in two or three directions. We will do this and then we will total the potentials in every direction. For convenience, we will use an evaluation grid as shown in Figure 11.17. Every square in this grid has been divided into four smaller ones. These internal squares are used to display the potential of each square in each direction. The square

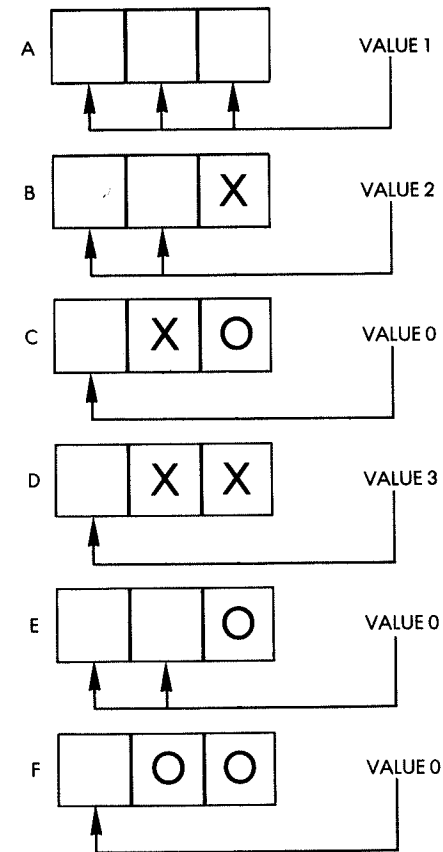

Fig. 11.16: The Six Combinations

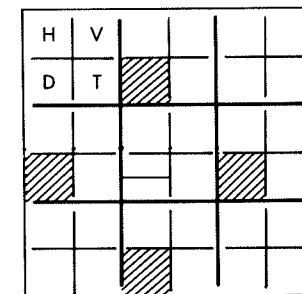

Fig. 11.17: Evaluation Grid

labeled "H" in Figure 11.17 will be used to evaluate the horizontal row potential. "V" will be used for the vertical column potential. "D" will be used for the diagonal potential. "T" will be used for the total of the previous three squares. Note that there is no diagonal value shown for four of the squares on the board. This is because they are not placed on diagonals. Also note that the center square has two diagonal values since it is at the intersection of two diagonals.

Once our algorithm has computed the total threat and win potentials for each square, it must then decide on the best square in which to move. The obvious solution is to move to the square having the highest win or threat potential.

Now we shall test the value of our algorithm on some real examples. We will look at some typical board configurations and evaluate them by using our algorithms to check if the moves it generates make sense.

A Test of the Initial Algorithm

Let us look at the situation in Figure 11.18. It is the player's turn ("O") to play. We will evaluate the board from two standpoints: potential for "X" and threat from "O." We will then select the square that has the highest total in each of the two grids generated and make our move there.

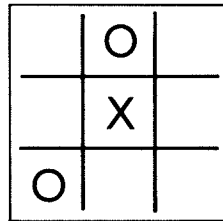

Fig. 11.18: Test Case 1

Let us first complete the evaluation grid for the first row. Since there is an "O" in the first row, the horizontal potential for the player is zero (refer to row C, Figure 11.16 and look up the value of this configuration). This is indicated in Figure 11.19. Let us now look at row 2: it contains two blank squares and an "X." Referring to line B of Figure 11.16, the corresponding value is "two." It is entered at the appropriate location in the grid, as shown in Figure 11.20. Finally, the

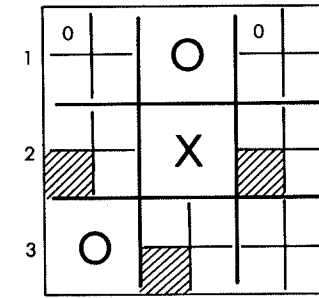

Fig. 11.19: Evaluation Grid: Row 1 Potential

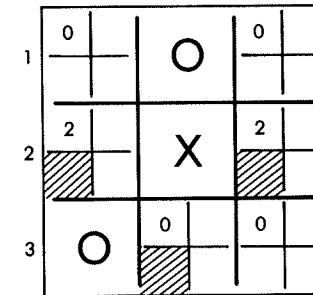

Fig. 11.20: Evaluating the Horizontal Potential

third row is examined, and since there is an "O" in it, the row potential is "zero," as indicated in Figure 11.20. The process is then repeated for the three columns. The result is indicated in Figure 11.21.

The value of each square of column 1 is "zero," since there is an "O" at the bottom. Similarly, for column 2 the value is also "zero," and for column 3 it is "one" for each square, since all three squares are open (blank). (Refer to line A in Figure 11.16.)

The process is repeated for each of the two diagonals and the results are shown in Figure 11.22. Finally, the total is computed for each square. The results are shown in Figure 11.23. Remember that the total appears in the bottom right-hand corner of each square.

It can be seen that at this point, two squares (indicated by an arrow in Figure 11.23) have the highest total, "three." This indicates where

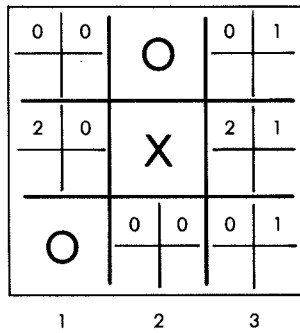

Fig. 11.21: Evaluating the Vertical Potential

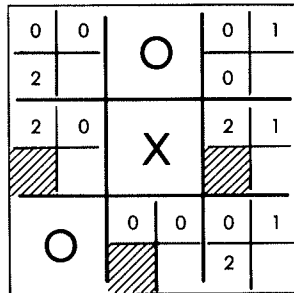

Fig. 11.22: Evaluating the Diagonal Potential

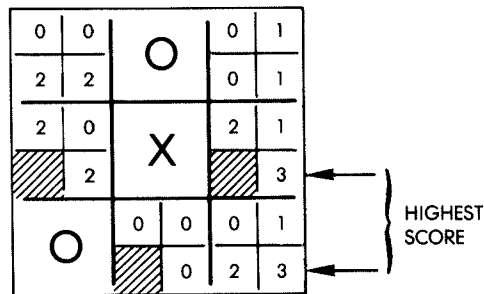

Fig. 11.23: The Final Potential

we should play. But wait! We have not yet examined the threat, i.e., the potential from our opponent "O."

We will now evaluate the threat posed by "O" by again computing the potential of each square on the board, but this time from "O's" standpoint. The position values for the six meaningful combinations are indicated in Figure 11.24. When we apply this strategy to our evaluation grid, we obtain the results shown in Figure 11.25. The square with the highest score is the one indicated by the arrow. It scores "four," which is higher than the two previous squares that were determined when we evaluated the potential for "X."

Using our algorithm, we decide that the move we should make is to play into square 1, as indicated in Figure 11.26.

Let us verify whether this was indeed the appropriate move, assuming that each player makes the best possible move. A continuation of the game is shown in Figure 11.27. It results in a draw.

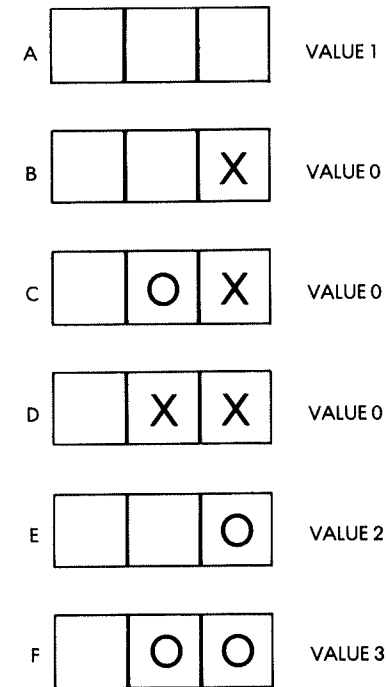

Fig. 11.24: Evaluation for "O"

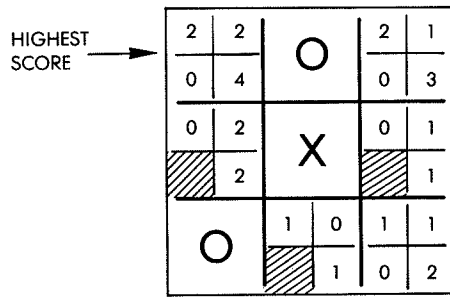

Fig. 11.25: Potential Evaluation

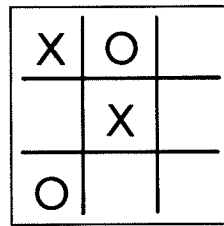

Fig. 11.26: Move for Highest Score

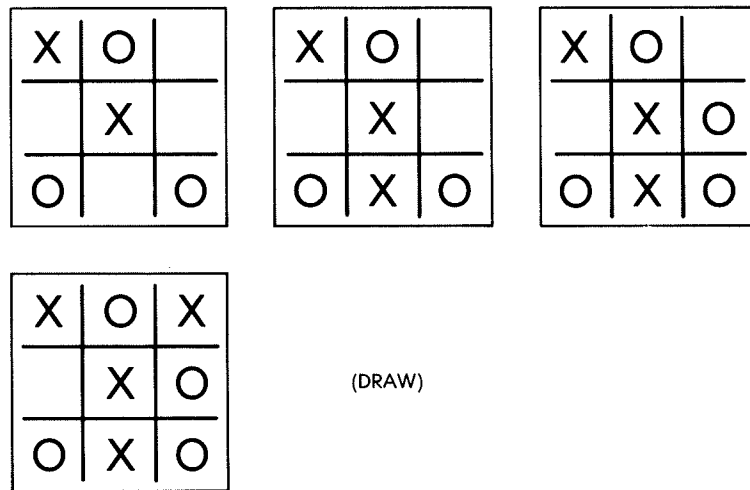

Fig. 11.27: Finishing the Game

Let us now examine what would have happened if we had not evaluated the threat and played only according to the highest potential for "X" as shown in Figure 11.23. This alternative ending for the game is shown in Figure 11.28. This game also results in a draw. In this instance, then, the square with the value "four" did not truly have a higher strategic value than the one with the value "three." However, our algorithm worked.

Let us now test our algorithm under more difficult circumstances.

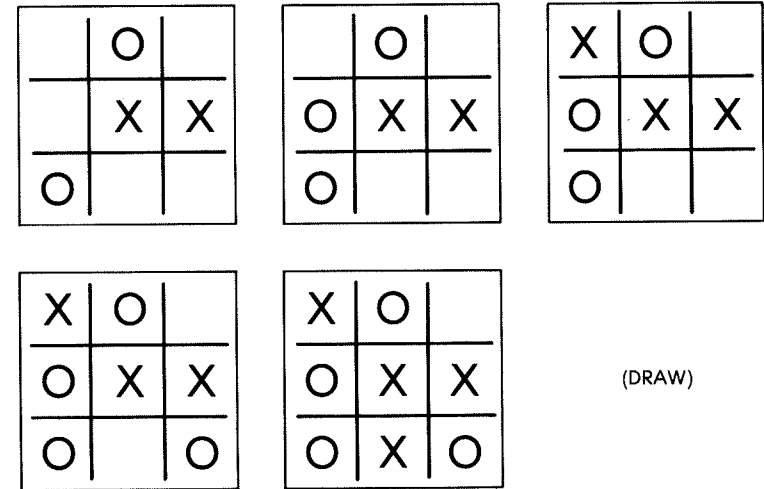

Fig. 11.28: An Alternative Ending for the Game

Improving the Algorithm

In order to test our algorithm, we should consider clear-cut situations in which there is one move that is best. To begin, we will assume that it is the player's turn. The first test situation, evaluated for "X," is illustrated in Figure 11.29, and the potential for "O" is shown in Figure 11.30. This time we have a problem. The highest overall potential is "four" for "X" in the lower right corner square. If the computer moved there, however, the player would win! At this point our algorithm should be refined.

We should note that whenever there are already two "X"s in a row the configuration should result in a very high potential for the third square. We should therefore assign it a value of "five" rather than

| | | | | | |
|---|---|---|---|---|---|
| 0 | 1 | 0 | 3 | | |
| 2 | 3 | | 3 | ○ | |
| 2 | 1 | | X | 2 | 0 |
| | 3 | | | | 2 |
| 2 | 1 | | X | 2 | 0 |
| 0 | 3 | | | 2 | 4 |

Fig. 11.29: Test #1 Evaluated for "X"

| | | | | | |
|---|---|---|---|---|---|
| 2 | 1 | 2 | 0 | | |
| 0 | 3 | | 2 | ○ | |
| 0 | 1 | | X | 0 | 1 |
| | 1 | | | | 1 |
| 0 | 1 | | X | 0 | 1 |
| 0 | 1 | | | 0 | 1 |

Fig. 11.30: Test #1 Evaluated for "O"

| | | | | | |
|---|---|---|---|---|---|
| | X | | ○ | | ○ |
| 2 | 2 | | X | 2 | 0 |
| | 4 | | | | 2 |
| 1 | 2 | 1 | 0 | 1 | 0 |
| 0 | 3 | | 1 | 5 | 6 |

← PLAY THERE

Fig. 11.31: Test #2

"three" to ensure that we move there automatically. We have thereby identified and made our first improvement to the algorithm.

The second test situation is shown in Figure 11.31. Our algorithm assigns the value "six" to the lower right corner square (as indicated by an arrow in Figure 11.31). This is clearly the correct move. It works! Now, let us test the improvement we have made.

The First Move

When the board is empty, our algorithm must decide which square should be occupied first. Let us examine what this algorithm does. (The results are shown in Figure 11.32.) The algorithm always chooses to move to the center. This is reasonable. It could be shown, however, that it is not indispensable in the game of Tic-Tac-Toe. In fact, having the computer always move to the center makes it appear "boring," or simply "lacking imagination." Something will need to be done about this. This will be shown in the final implementation.

| | | | | | |
|---|---|---|---|---|---|
| 1 | 1 | 1 | 1 | 1 | 1 |
| 1 | 3 | | 2 | 1 | 3 |
| 1 | 1 | 1 | 1 | 1 | 1 |
| | 2 | 1 | 4 | | 2 |
| 1 | 1 | 1 | 1 | 1 | 1 |
| 1 | 3 | | 2 | 1 | 3 |

Fig. 11.32: Moving to the Center

Another Test

Let us try one more simple situation. This situation is shown in Figure 11.33. Again, the recommended move is a reasonable one. The reverse situation is shown in Figure 11.34 and does, indeed, lead to a certain win. So far, our algorithm seems to work. Let us try a new trap.

A Trap

The situation is shown in Figure 11.35. It is now "X's" turn to play. Using our algorithm, we will move into one of the two squares having

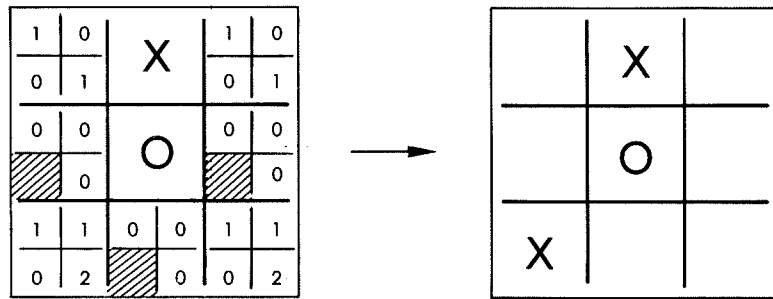

Fig. 11.33: A Simple Situation

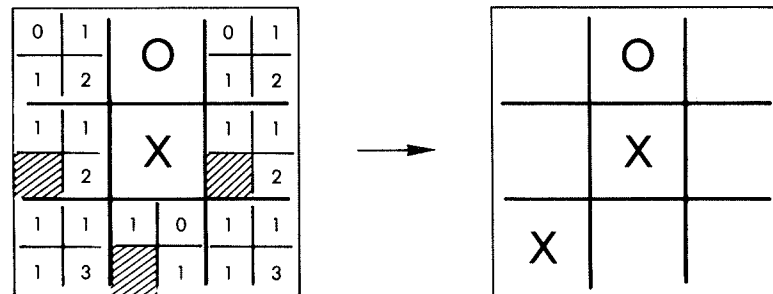

Fig. 11.34: A Reverse Situation

the total of "four." This time, however, such a move would be an error! Assuming such a move, the end of the game is shown in Figure 11.36. It can be seen that "O" wins. The move by "X" was an incorrect choice if there was a way to get at least a draw. The correct move that would lead to a draw is shown in Figure 11.37. This time, our algorithm has failed. Following is a simple analysis of the cause: it moved to a square position of value "four" corresponding to a high level of threat by "O," but left another square with an equal threat value unprotected (see Figure 11.35). Basically, this means that if "O" is left free to move in a square whose threat potential is equal to "four," it will probably win. In other words, whenever the threat posed by "O" reaches a certain threshold, the algorithm should consider alternative strategies. In this instance, the strategy should be to place an "X" in a square that is horizontally or vertically adjacent to

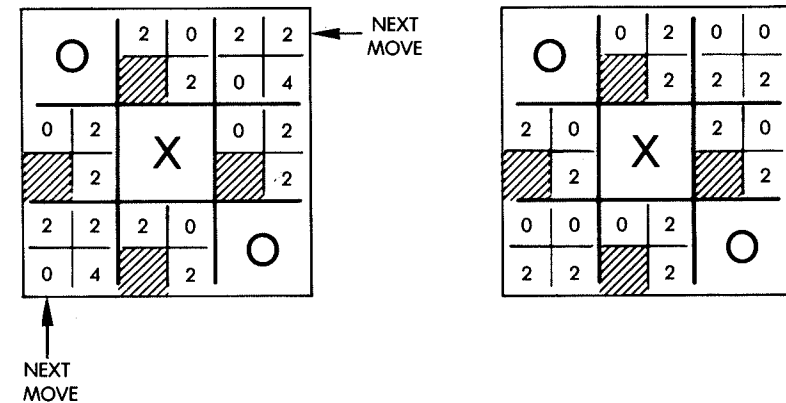

Fig. 11.35: Trap 3

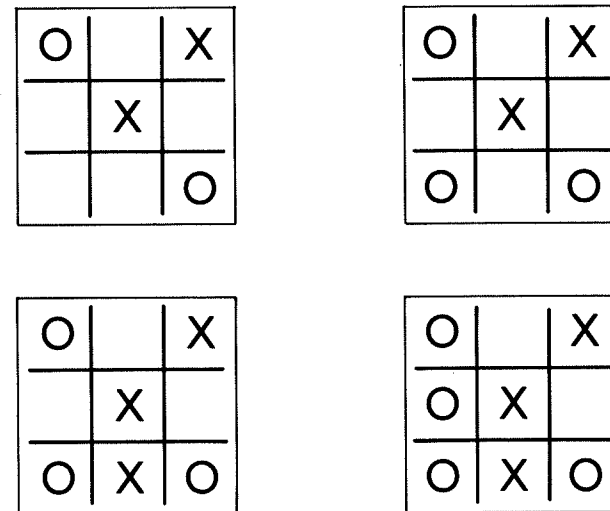

Fig. 11.36: End of Game

the first one in order to create an imminent "lose threat" for "O," and thereby force "O" to play into the desired square. In short, this means that the algorithm should analyze the situation further or better still, analyze the situation one level deeper, i.e., one turn ahead. This is called two-ply analysis.

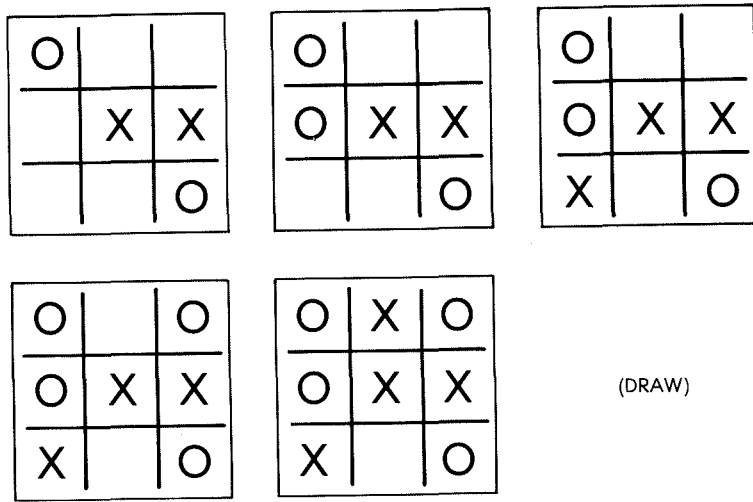

Fig. 11.37: A Correct Move

In conclusion, our algorithm is simple and generally satisfactory. However, in at least one instance, Trap 3 in Figure 11.35, it fails. We must therefore, include either a special consideration for this case, or we must analyze the situation one turn ahead every time and look at what would happen if we were to place an "X" or an "O" in every one of the available squares. The latter is actually the "cleanest" solution. Ideally, we should analyze all of the possible sequences until an end-of-game situation is obtained. The programming complexity, the storage required, and the time that would be needed to analyze the situations would, however, make this approach impractical. In a more complex game, such as chess or checkers, it would be necessary to use such a multi-ply analysis. For example, using only a two-ply analysis technique to design a simple chess game would not make it very interesting or very good. It would be necessary to use three-ply, four-ply or even more detailed analysis in order to make the game challenging.

If it is not possible to push the evaluation to a sufficient depth, the algorithm must be equipped with specific procedures that can detect special cases. This is the case with *ad hoc* programming, which can be considered "unclean" but actually results in a much shorter program and/or a lesser memory requirement. In other words, if the special situations in a game can be recognized in advance, then it is

possible to write a special-purpose program which will take these situations into account. The resulting program will usually be shorter than the completely general one. This type of program, however, can only be constructed if the programmer has an excellent initial understanding of the game.

In the game of Tic-Tac-Toe, the number of combinations is limited. This makes it possible to examine all possible combinations that can be played on the board and to devise a procedure that takes all of these cases into account. Since we are primarily limited here by the amount of available memory, we will construct an *ad hoc* algorithm that fits within 1K of memory. Alternative techniques will be proposed as exercises.

The Ad Hoc Algorithm

This algorithm assigns a value to each square on the board depending on who has played there. Initially a value of "zero" is assigned to each square on the board. Every time the player occupies a square, however, the corresponding value of the square becomes "one." Every time the computer occupies a square, the value of that square becomes "four." This is illustrated in Figure 11.38. The value of "four" has been chosen so that it is possible to know the combination of moves in that row just by looking at the total of every row. For example, if a row consists of a move by the player and two empty squares, its "row-sum" is "one." If the player has played twice, its row-sum is "two." If the player has played three times, the row-sum is "three." Since "three" is the highest total that can be achieved in rows where only the player has played, the value of "four" has been assigned to a computer move. For example, if the value of a row is "five," we know that there is one computer move ("X"), one player move ("O"), and one empty square. The six possible patterns are shown in Figure 11.38. It can readily be seen that the row-sum values of "two" or "eight" are winning situations. A row-sum value of "five" is a blocked position, i.e., one that has no value for the player. If a win situation is not possible, then the best potentials are represented by either a value of "one" or a value of "four" depending on whose turn it is to play.

The algorithm is based on such observations. It will first look for a win by checking to see if there is a row-sum of value "eight." If this is the case, it will play there. If not, the algorithm will check for a so-called "trap" situation in which two intersecting rows each have a computer move in them and nothing else (the algorithm is always used

| PATTERN | ROWSUM VALUE | | | | |
|---|--------------|---|--|---|-----------|
| <table border="1"><tr><td> </td><td> </td><td> </td></tr></table> | | | | 0 | |
| | | | | | |
| <table border="1"><tr><td>O</td><td> </td><td> </td></tr></table> | O | | | 1 | |
| O | | | | | |
| <table border="1"><tr><td>O</td><td>O</td><td> </td></tr></table> | O | O | | 2 | (WIN) |
| O | O | | | | |
| <table border="1"><tr><td>X</td><td> </td><td> </td></tr></table> | X | | | 4 | |
| X | | | | | |
| <table border="1"><tr><td>X</td><td>X</td><td> </td></tr></table> | X | X | | 8 | (WIN) |
| X | X | | | | |
| <table border="1"><tr><td>O</td><td>X</td><td> </td></tr></table> | O | X | | 5 | (BLOCKED) |
| O | X | | | | |

Fig. 11.38: Row-sums

for the computer's benefit). This is illustrated in Figure 11.39. By examining Figure 11.39, it becomes clear that each unoccupied square that belongs to two rows having a row-sum of "four" is a trap position where the algorithm should play. This is exactly what it does.

The complete flowchart for the board analysis is shown in Figure 11.40. Now, let us examine it in more detail. Remember that it is always the computer's turn when this algorithm is invoked.

First, it checks for a possible immediate win. In practice, we will examine all row-sums and look for one which has a total of "eight." This would correspond to a case where there are two computer moves in the same row with the last square being empty. (Refer to Figure 11.38.)

Next, we will check for a possible player win. If the player can win with the next move, the algorithm must block this move. To do so, it should scan the row-sums and look for one that has a total of "two,"

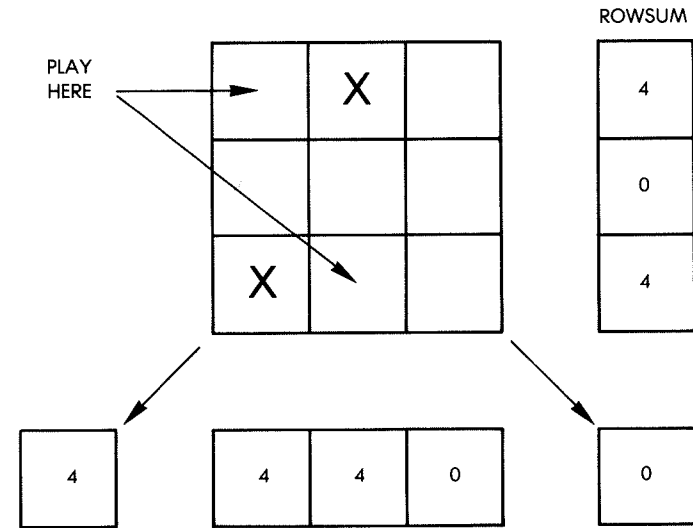

Fig. 11.39: A Trap Pattern

which would indicate a winning combination for the player. (Refer to Figure 11.38.)

At this point the algorithm should check to see if the computer can play into any of the trap positions defined above. (See Figure 11.39 for an example.)

One more feature has been built into the algorithm: the computer is equipped with a variable IQ level, i.e., with a variable level of intelligence. The above moves are ones that any "reasonable computer" must make. From this point on, however, the algorithm can let the computer make a few random moves and even possible mistakes if its intelligence level is set to a low level. In order to provide some variety to the game, we will obtain a random number, compare it to the IQ, and vary our play depending upon the results. If the IQ is set to the maximum, the program will always execute the right branch of the flowchart; however, if the IQ is not set to the maximum, it will sometimes execute the left branch. Let us follow the right branch of the flowchart. At this point, we will check for two special situations that correspond to moves #1 and #4 in the game.

For the first situation, i.e., the first move in a game, the algorithm will occupy any position on the board. That way, its behavior will be different every time and, thus, appear "intelligent."

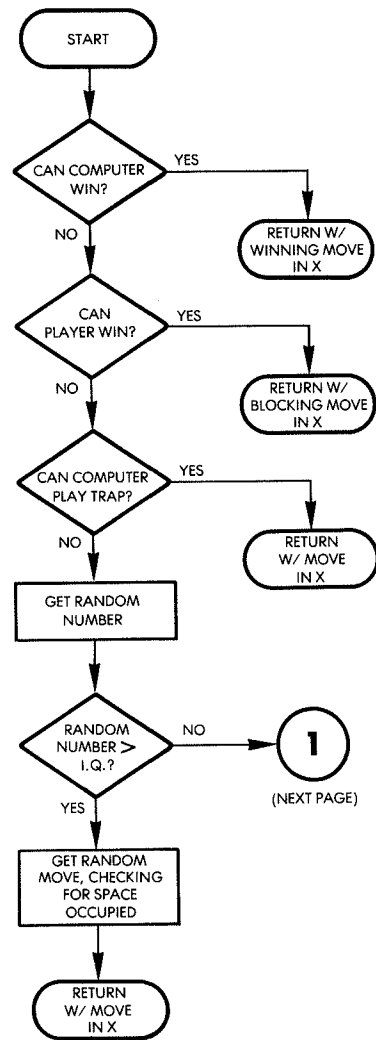

Fig. 11.40: Board Analysis Flowchart

For the next situation we must look at move #4. It is the computer's turn. In other words, the player started the game (move #1), the computer responded (move #2), then the player made his or her second move (move #3), and it is now the computer's turn. In short, in the game thus far, the player has played twice and the computer has

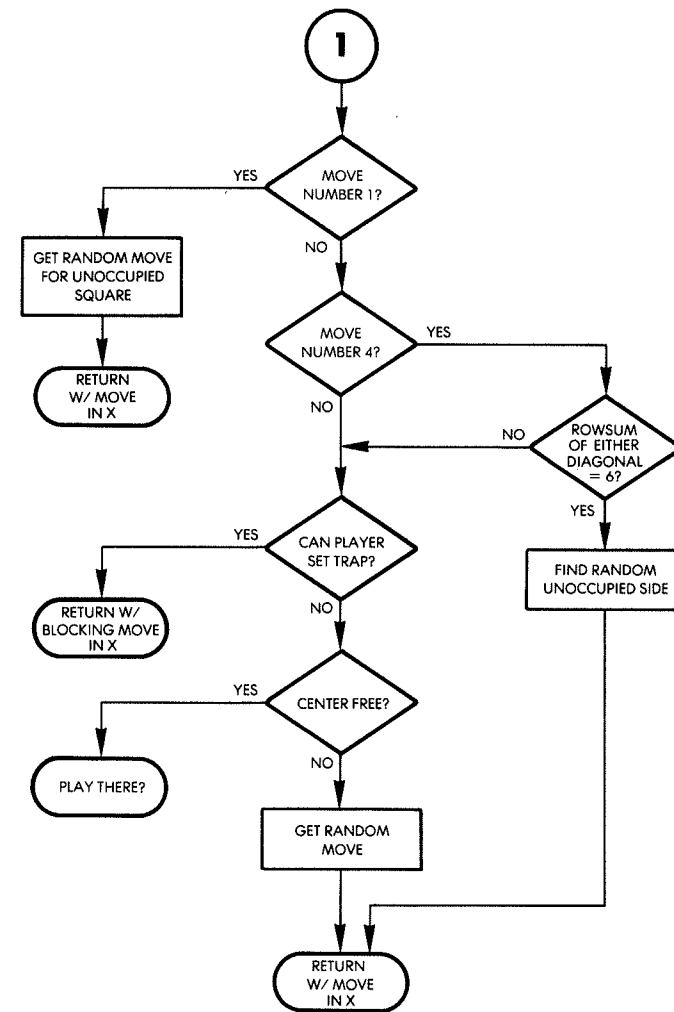

Fig. 11.40: Board Analysis Flowchart (Continued)

played once. At this point, we want to check to see if the first three moves have all been made along one of the diagonals. If so, since the player has made two moves and the computer has made one, the row-sum of one of the diagonals will be "six." The algorithm must check explicitly for this. If the first 3 moves have all been made along a

diagonal, the computer must move to a side position. This is a special situation which must be built into the algorithm, or it cannot be guaranteed that the computer (assuming the highest IQ level) will win every time. This situation is illustrated in Figure 11.41. Note that if straightforward logic was used, the algorithm would play into one of the free corners since a threat exists from the player that he or she might play there, and thereby set up a trap situation. The results of such an action are shown in Figure 11.42. By looking at this illustra-

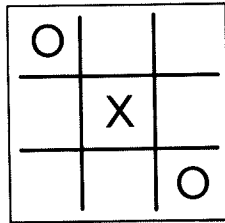

Fig. 11.41: The Diagonal Trap

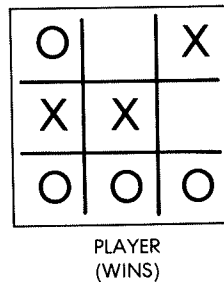
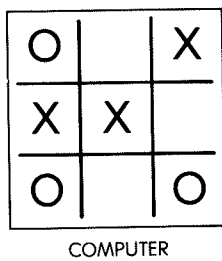
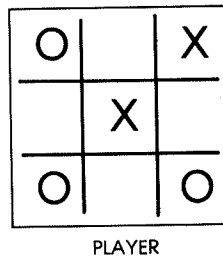
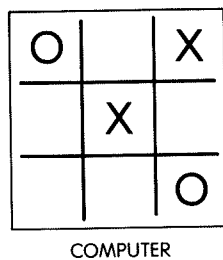

Fig. 11.42: Falling Into the Diagonal Trap

tion, it can be seen that such a move would result in a loss. However, let us examine what happens if we play on one of the sides. This situation is illustrated in Figure 11.43; it results in a draw. This is clearly the move that should be made. This is a relatively little-known trap in the game of Tic-Tac-Toe, and a provision must be built into the algorithm so that the computer will win.

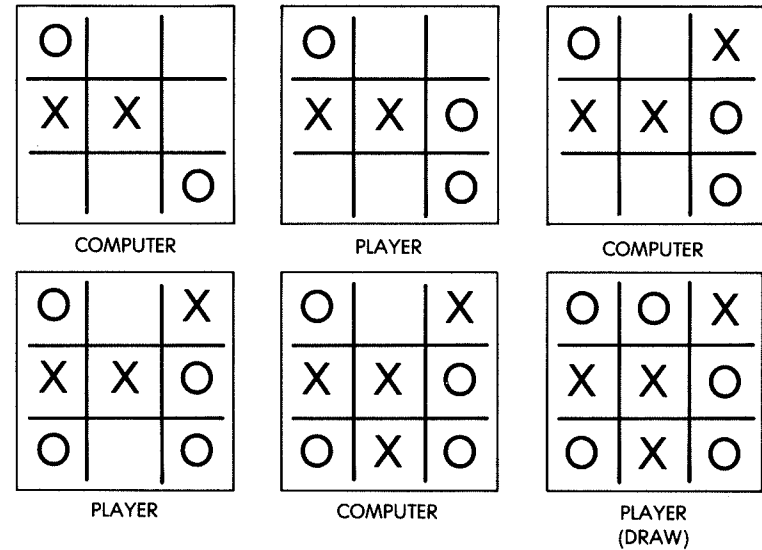

Fig. 11.43: Playing to the Side

If it was not the fourth move, or if there was not a diagonal trap set, the next thing the computer should do is to check to see if the player can set a trap. (Refer to the flowchart in Figure 11.40.) If the player can set a trap, the computer plays in the appropriate square to block it. Otherwise, the computer moves to the center square, if available; if that is not possible, it moves randomly to any position.

Since this algorithm was built in an *ad hoc* fashion, it is difficult to prove that it wins or achieves a draw in all cases. It is suggested that you try it on a board or that you try out the actual program on the Games Board. You will discover that in all conditions under which it has been tested, the computer always wins or achieves a draw. If the computer keeps winning, however, its IQ level will drop, and eventually it will allow the player to win. As an example, some sequences obtained on the actual board are shown in Figure 11.44.

| COMPUTER | PLAYER | COMPUTER | PLAYER | COMPUTER | PLAYER |
|----------|--------|----------|--------|----------|--------|
| 4 | 5 | | 5 | | 6 |
| 7 | 1 | 1 | 6 | 5 | 4 |
| 9 | 8 | 4 | 7 | 1 | 9 |
| 2 | (DRAW) | 3 | 2 | 3 | 7 |
| 8 | 5 | 8 | 9 | 2 | (LOSS) |
| 6 | 3 | (DRAW) | | | 6 |
| 7 | 9 | | 5 | 5 | 4 |
| 1 | 4 | 3 | 4 | 8 | 2 |
| (DRAW) | | 6 | 9 | 9 | 1 |
| 2 | 5 | 1 | 2 | 7 | (LOSS) |
| 9 | 1 | 8 | 7 | | 6 |
| 7 | 8 | (DRAW) | | 1 | 5 |
| 6 | 3 | | 2 | 4 | 7 |
| (DRAW) | | 5 | 1 | 3 | 2 |
| 8 | 5 | 3 | 7 | 8 | 9 |
| 1 | 7 | 4 | 6 | (DRAW) | |
| 3 | 2 | 9 | 8 | 9 | 5 |
| 6 | 9 | (DRAW) | | 3 | 6 |
| (DRAW) | | | 1 | 4 | 2 |
| 6 | 5 | 5 | 3 | 8 | 7 |
| 4 | 8 | 2 | 8 | (DRAW) | |
| 2 | 3 | 9 | 6 | | |
| 7 | 1 | 7 | 4 | | |
| (DRAW) | | (DRAW) | | | |

Fig. 11.44: Actual Game Sequences

Suggested Modifications

Exercise 11-1: Designate a special key on the Games Board that, when pressed will display the computer's IQ level.

Exercise 11-2: Modify the program so that the IQ level of the computer can be changed at the beginning of each game.

Credits

The *ad hoc* algorithm which was described in this section is believed to be original. Eric Novikoff was the main contributor. "Scientific American" (selected issues from 1950 through 1978), as well as Dr. Harvard Holmes must also be credited with having provided several original ideas.

Alternative Strategies

Other strategies can also be considered. In particular, a short program can be designed by using tables of moves that correspond to various board patterns. The tables can be short because when symmetries and rotations are taken into account, the number of situations that can be represented is limited. This type of approach results in a shorter program, however, the program is somewhat less interesting to design.

Exercise 11-3: Design a Tic-Tac-Toe program using this type of table.

THE PROGRAM

The overall organization of the program is quite simple. It is shown in Figure 11.42. The most complex part is the algorithm that is used to determine the next move by the computer. This algorithm, called "FINDMOVE," was previously described.

Let us now examine the overall program organization. The corresponding flowchart is shown in Figure 11.45.

1. The computer IQ level is set to 75 percent.
2. The user's keystroke is read.
3. The key is checked for the value "F." If it is an "F," the player starts; otherwise the computer starts. Depending on the value of the key pressed, the flowchart continues into boxes 4 or 5, then to 6.

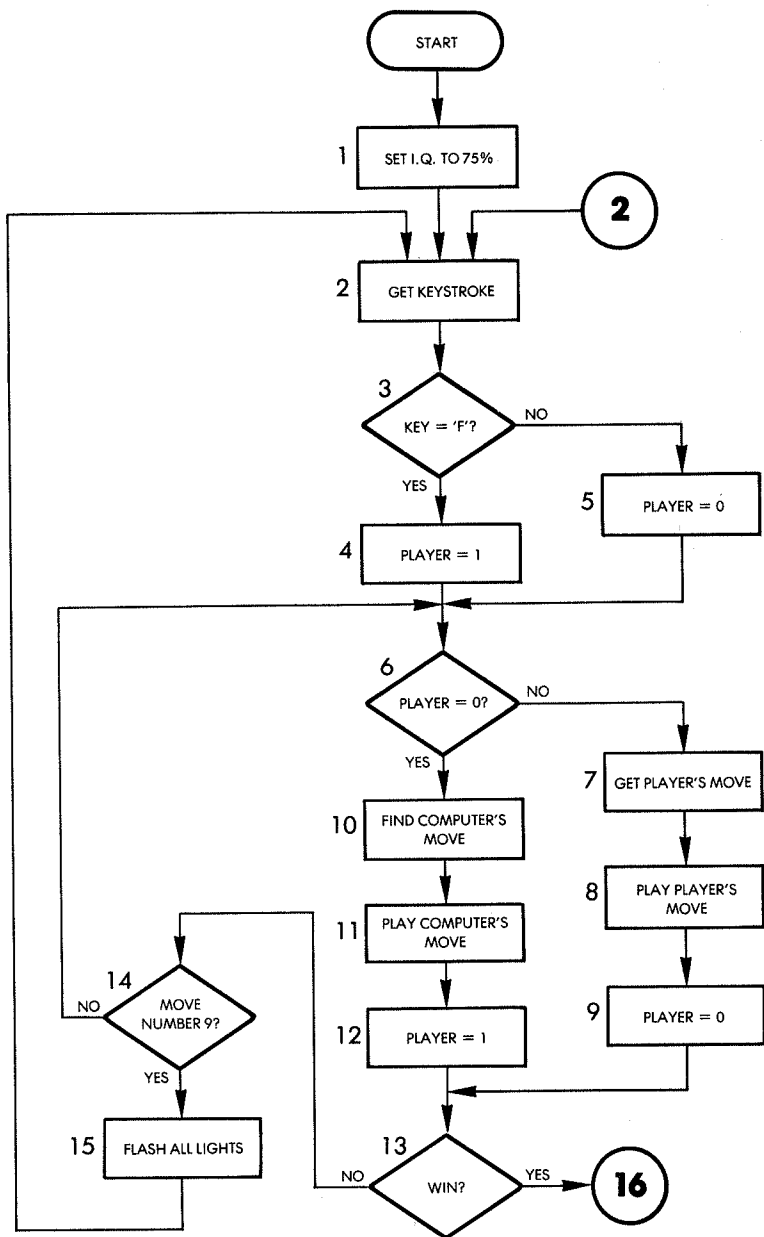

Fig. 11.45: Tic-Tac-Toe Flowchart

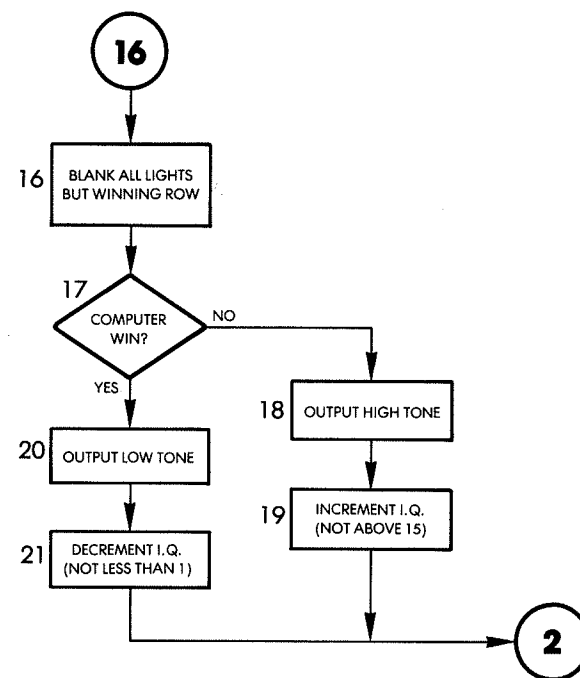

Fig. 11.45: Tic-Tac-Toe Flowchart (Continued)

If the player starts (PLAYER is not equal to "0"), then we move to the left side of the flowchart.

- 7. The key, pressed by the player specifying his or her move, is read and the move is displayed on the board.
- 8. The corresponding LED is lit on the board. It then becomes the computer's turn to play and the variable PLAYER is set to "0" in box 9.

When exiting from box 6, if it is the computer's turn, we move to box 10.

- 11. The next move to be made by the computer must be computed at this time.

This is the complex algorithm we have described above.

- 11. Next, the computer's move is displayed.
- 12. PLAYER is reset to "one" to reflect the fact that it is now the player's turn.

After either party has moved, the board is checked for a winning se-

quence of lights in box 13. If there is not a winning sequence of lights, we move to the left on the flowchart.

14. We next check to see if all moves have been exhausted: we check for move #9. If the ninth LED is lit and a winning situation has not been detected, it is a draw, and all lights on the board must be flashed.

15. We flash all the LEDs on the board. Then, we return to box 6 and the next player plays.

When exiting from box 13, if there is a win situation, this fact must be displayed:

16. All of the lights are blanked except for the winning three LEDs. Next, it must be determined by the algorithm whether the player or the computer has won.

17. A determination is made as to whether it was the player or the computer who won. If the computer has won, we branch to the right on the flowchart.

18. A low frequency tone is sounded.

19. The computer's IQ is decremented (to a minimum of 0).

The situation for a player win, shown in boxes 20 and 21, is analogous.

The general program flow is straightforward. Now, we shall examine the complete information. The subroutine which analyzes the board situation is called "ANALYZE" and uses "UPDATE" as a subroutine to compute the values of various board positions.

Data Structures

The main data structure used by this program is a linear table with three entry points that are used to store the eight possible square alignments on the board. When evaluating the board, the program will have to scan each possible alignment for three squares every time. In order to facilitate this process, all possible alignments have been listed explicitly, and the memory organization is shown in Figure 11.46.

The table is organized in three sections starting at RWPT1, RWPT2, and RWPT3 (RWPT stands for "row pointer"). For example, the first elements RWPT1, RWPT2, and RWPT3, for the first three-square sequence are looked at by the evaluation routine. The sequence is: "0, 3, 6," as indicated by the arrows in Figure 11.43. The next three-square sequence is obtained by looking at the second entry in each RWPT table. It is "1, 4, 7," which is, in fact, the second column on our LED matrix.

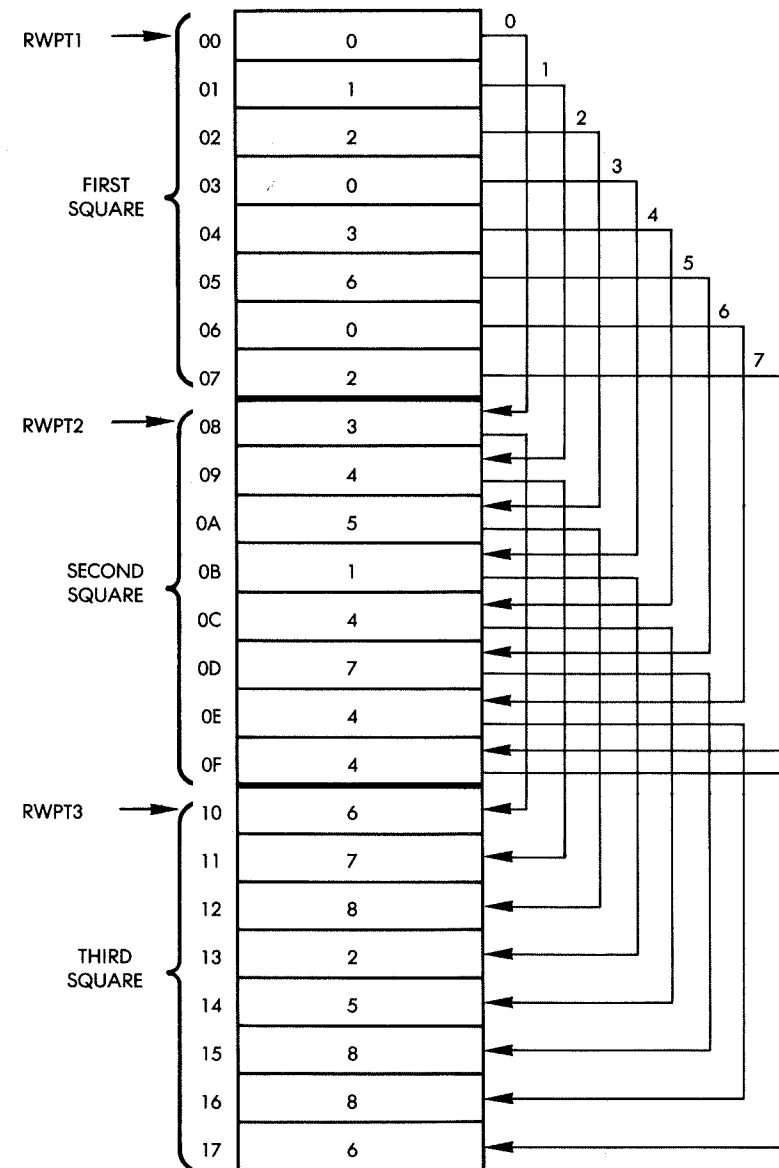

Fig. 11.46: Tic-Tac-Toe Row Sequences in Memory

The table has been organized in three sections in order to facilitate access. To be able to access all of the elements successfully, it will be necessary to keep a running pointer that can be used as an index for efficient table access. For example, if we number our generalized rows of sequences from 0 to 7, "row" 3 will be accessed by retrieving elements at addresses RWPT1 + 3, RWPT2 + 3, RWPT3 + 3. (It is the sequence "0, 1, 2," as seen in Figure 11.46.)

Memory Organization

Page 0 contains the RWPT table which has just been described, as well as several other tables and variables. The rest of the low memory is shown in Figure 11.47.

The GMBRD table occupies nine locations and stores the status of the board at all times. A value of "one" is used to indicate a position occupied by the player, and a value of "four" indicates a position occupied by the computer.

The SQSTAT table also occupies nine words of memory and is used to compute the tactical status of the board.

The ROWSUM table occupies eight words and is used to compute the value of each of the eight generalized rows on the square.

The RNDSCR table occupies six words and is used by the random number generator.

The remaining locations are used by temporary variables, masks, and constants, as indicated in Figure 11.47. The role of each variable or constant will be explained as we describe each routine in the program.

High Memory

High memory locations are essentially reserved for input/output devices. Ports 1 and 3 are used, as well as interrupts. The corresponding memory map is shown in Figure 11.48. The interrupt-vector resides at addresses A67E and A67F. It will be modified at the beginning of the program so that interrupts will be generated automatically by the interval timer. These interrupts will be used to blink the LEDs on the board.

Detailed Program Description

At the beginning of each game, the intelligence level of the computer is set at 75 percent. Each time that the player wins, the IQ level

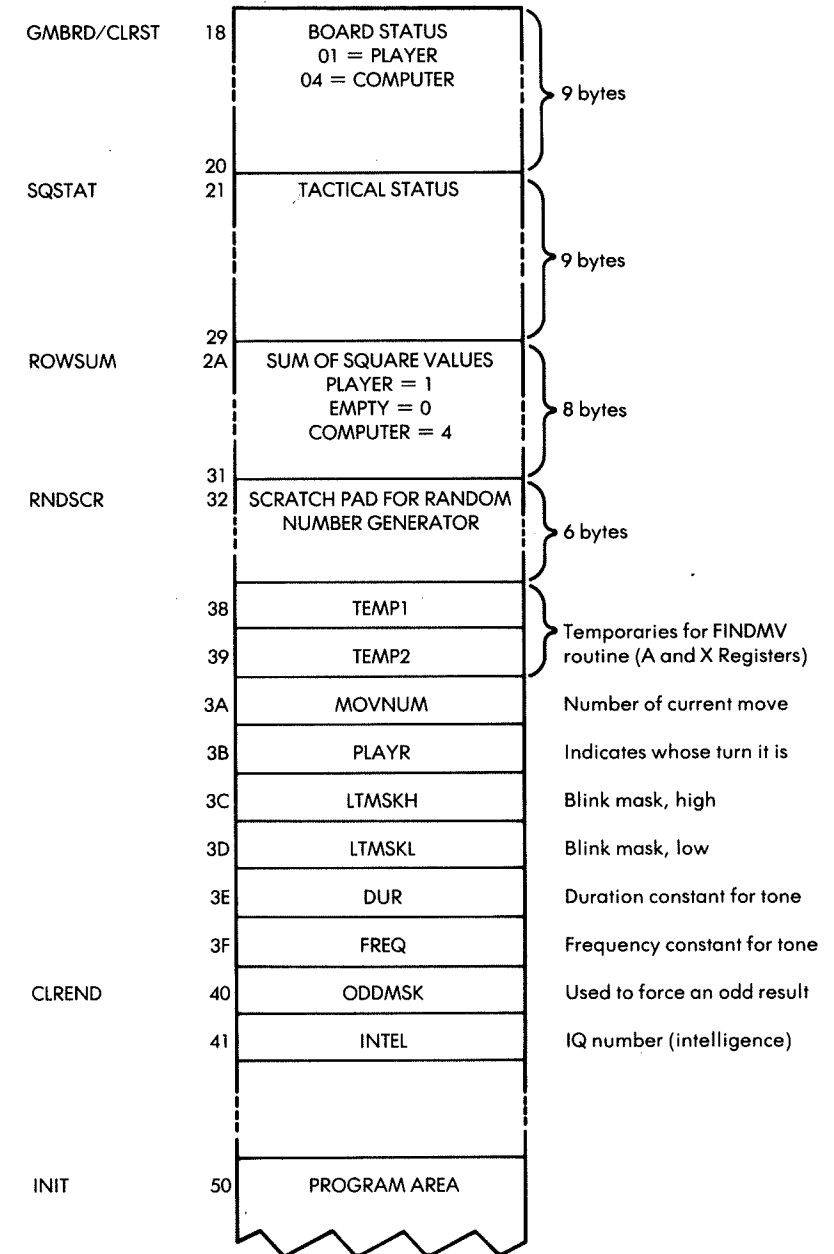

Fig. 11.47: Tic-Tac-Toe: Low Memory

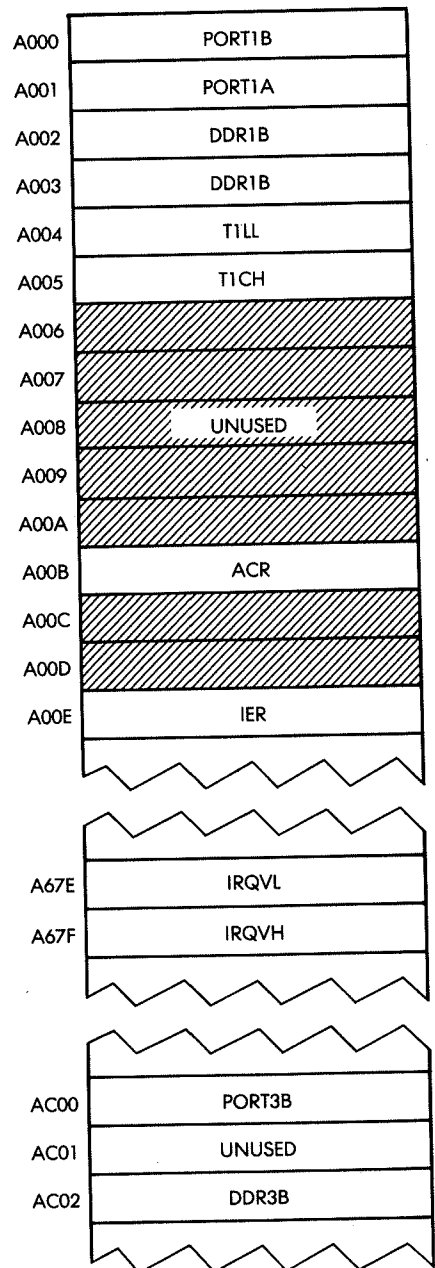

Fig. 11.48: Tic-Tac-Toe: High Memory

will be raised by one point. Each time that the player loses, it will be decremented by one point. It is initially set at the value 12 decimal:

```
START      LDA #12
           STA INTEL      Set IQ at 75%
```

Initialization occurs next:

```
RESTRT    JSR INIT
```

Let us examine the INIT subroutine which has just been called. It resides at address 0050 and appears on lines 0345 and following on the program listing. The first action of the initialization subroutine is to clear all low memory locations used by program variables. The locations to be cleared are those between CLRST and CLREND (see lines 41 and 57 of the program listing). Note that a seldom-used facility of the assembler — multiple labels for the same line — has been utilized to facilitate the clearing of the correct number of memory locations. Since it may be necessary to introduce more temporary variables in the course of program development, a specific label was assigned to the first location to be cleared, CLRST (memory location 18), and another to the last location to be cleared (CLREND). For example, memory location 18 corresponds both to CLRST and to GMBRD. The clearing operation should start at address CLRST and proceed forward forty locations (CLREND-CLRST). Thus, we first load the number of locations to be cleared into index register X, then we use a loop to clear all of the required locations:

```
INIT      LDA #0
           LDX #CLREND-CLRST
CLRALL    STA CLRST,X    Clear location
           DEX
           BPL CLRALL
```

After low memory has been cleared, the two starting locations for the random number generator must be seeded. As usual, the low-counter of timer 1 is used:

```
LDA T1LL
STA RNDSCR + 1
STA RNDSCR + 4
```

Ports 1A, 1B, and 3B are then configured as outputs. The appropriate pattern is loaded into the data direction registers:

```
LDA #$FF
STA DDR1A
STA DDR1B
STA DDR3B
```

All LEDs on the board are turned off:

```
LDA #0
STA PORT1A
STA PORT1B
```

Next, the interrupt vector's address must be loaded with a new pointer. The address to be deposited there is the address of the interrupt handler, which has been designed to provide the regular blinking of the LEDs. (This process has already been explained in previous chapters.) The interrupt handler resides at address INTVEC. The high byte and the low byte of this address will be loaded in memory locations IRQVH and IRQVL, respectively. A special assembler symbol is used to denote the low byte of the interrupt vector: #<INTVEC. Conversely, the high byte is represented in assembly language by #>INTVEC. The new interrupt vector is loaded at the specified memory locations:

```
JSR ACCESS
LDA #<INTVEC
STA IRQVL      Low vector
LDA #>INTVEC
STA IRQVH      High vector
```

As usual, the interrupt-enable register must first be cleared, then the appropriate interrupt must be enabled:

```
LDA #$7F
STA IER        Clear register
LDA #$C0
STA IER        Enable interrupt
```

Timer 1 is set to the free-running mode:

```
LDA #$40
STA ACR
```

The latch for timer 1 is loaded with the highest possible count, "FFFF":

```
LDA #$FF
STA T1LL
STA T1CH
```

Finally, interrupts are enabled, the decimal mode is cleared as a precaution, and we terminate the initialization stage:

```
CLI
CLD
RTS
```

Back to the Main Program

We are now at line 69 of the program listing. We read the next key closure on the keyboard:

```
JSR GETKEY
```

It is the first move. We must determine whether it is an "F" or not. If it is an "F," the player moves first; otherwise the computer moves first. Let us check it:

```
CMP #$F
BNE PLAYLP
```

It is the player's turn and this information is stored in the temporary variable PLAYR, shown in Figure 11.44:

```
LDA #01
STA PLAYR
```

It is time for a new move, and the move counter is incremented by one. Variable MOVNUM is stored in low memory. This is shown in Figure 11.44. It is now incremented:

```
PLAYLP      INC MOVNUM
```

At this point, PLAYR indicates whose turn it is to play. If it is set at "zero," it is the computer's turn. If it is set at "one," it is the player's turn. Let us check it:

```
LDA PLAYR
BEQ CMPMU
```

We will assume here that it is the player's turn. PLAYR is reset to "zero" so that the computer will make its move next:

```
DEC PLAYR
```

The player's move is received by the PLRMV subroutine which will be described below. Let us allow the player to play:

```
JSR PLRMV
```

The move made by the player is specified at this point by the contents of the X register. Since it was the player's move, the corresponding code on the board's representation should be "01," which will be deposited in the accumulator:

```
LDA #01
```

We will now display the move on the board by blinking the proper LED. In addition, the corresponding ROWSUM will automatically be updated:

```
JSR UPDATE
```

The UPDATE routine will be described in detail below. Once the move has been made, we should check for a possible win. In the case of a win, the player has three blinking LEDs in a row, and the corresponding row total is automatically equal to "three." We will therefore simply check all eight rows for a ROWSUM of three:

```
LDA #03
BNE WINTST
```

At address WINTST a test is performed for a winning configuration. Index register Y is loaded with "seven" and used as a loop

counter. All of the rows, 7 through 0, are checked for the value "three":

```
WINTST   LDY #7
TSTLP   CMP ROWSUM,4
        BEQ WIN
        DEY
        BPL TSTLP
```

Let us now continue with the player's move. We will examine the computer's move later. (The computer's move corresponds to lines 83-88 of the program listing, which have not been described yet.) A maximum of nine moves is possible in this game. Let us verify whether or not we have reached the end of the game by checking the value of MOVNUM, which contains the number of the current move:

```
LDA MOVNUM
CMP #9
BNE PLAYLP
```

This is the end of our main loop. At this point, a branch occurs back to location PLAYLP, and execution of the main program resumes.

If we had reached the end of the game at this point, the game would be a tie, since there has not been a winner yet. At this point all of the lights on the board would be set blinking and then the game would restart. Let us set the lights blinking:

```
LDA #$FF
STA LTMSKL
STA LTMSKH
BNE DLY
```

The delay is introduced to guarantee that the lights will be blinked for a short interval. Let us now examine the end-of-game sequence.

When a win situation is found, it is either the player's win or the computer's win. When the player wins, the row total is equal to "three." When the computer wins, the row total is equal to "twelve." (Recall that each computer move results in a value of "four" for the square. Three squares in a row will result in $3 \times 4 = 12$.) If the computer won, its IQ will be decremented:

```
WIN CMP#12
BEQ INTDN
```

At this point a jump would occur to INTDN, where the intelligence level will be decreased (intelligence lowered).

A losing tone will be generated to indicate to the player that he or she has lost. The corresponding frequency constant is "FF," and it is stored at address `FREQ`:

```
INTDN    LDA #$FF
         STA FREQ
```

The intelligence level will now be decreased unless it has already reached "zero" in which case it will remain at that value:

```
LDA INTEL
BEQ GTMSK
DEC INTEL
```

For a brief time the winning row will be illuminated on the board, and the end-of-game tone will be played. First, we clear all LEDs on the board:

```
GTMSK    LDA #0
         STA PORT1A
         STA PORT1B
```

At this point, the number of the winning row is contained in index register Y. The three squares corresponding to that row will simply be retrieved from the `RWPT` table. (See Figure 11.43.) Let us display the first square:

```
LDX RWPT1,Y
JSR LEDLTR
```

The `LEDLTR` routine will be described below. It lights up the square whose number is contained in register X. Let us now display the next square:

```
LDX RWPT2,Y
JSR LEDLTR
```

Then, the third one:

```
LDX RWPT3,Y
JSR LEDLTR
```

At this point, we should turn off all unnecessary blinking LEDs on the board. The new pattern to be blinked is the one with the winning row and we must, therefore, change the `LTMSKL` mask:

```
LDA PORT1A
AND LTMSKL
STA LTMSKL
```

We now do the same for Port 1B:

```
LDA PORT1B
AND LTMSKH
STA LTMSKH
```

Exercise 11-4: *Subroutine `LEDLTR` on line 125 of the program listing has just lit the third LED on the board for the winning row. Immediately after that, we start reading the contents of Port 1A, and then Port 1B.*

There is, however, the theoretical possibility that an interrupt might occur immediately after `LEDLTR`, that might change the contents of Port 1A. Would this be a problem? If it would not be a problem, why not? If it would, modify the program to make it always work correctly.

At this point, Ports A and B contain the appropriate pattern to light the winning row. If the player has won, the blink masks `LTMSKL` and `LTMSKH` contain the same pattern, and will blink the row. We are now ready to sound the win or lose tone. The duration is set at "FF":

```
LDA #$FF
STA DUR
```

The frequency, `FREQ`, was set above. We simply have to play it:

```
LDA FREQ
JSR TONE
```

A delay must be provided:

```
DLY      JSR DELAY
```

We are now ready to start a new game with the new intelligence level of the computer:

```
JMP RESTART
```

Back to WIN

Let us now go back to line 103 of the program listing and examine the case in which the computer did not win (i.e., the player won). A different frequency constant is loaded at location `FREQ`:

```
LDA #30
STA FREQ
```

Since the player won, the intelligence level of the computer will be raised this time. Before it is raised, however, it must be checked against the value "fifteen," which is our legal maximum:

```
LDA INTEL
CMP #$0F
BEQ GTMSK
INC INTEL
```

The sequence was exactly analogous to the one in which the computer wins, except for a different tone frequency, and for the fact that the intelligence level of the computer is increased rather than decreased.

The Computer Moves

Let us now go back to line 83 of the program listing and describe what happens when the computer makes a move. Variable `PLAYR` is incremented, then a delay is provided to simulate "thinking time" for the computer:

```
COMPMV   INC PLAYR
          JSR DELAY
```

The computer move is determined by the `ANALYZ` routine described

below:

```
JSR ANALYZ
```

The computer's move is entered as a "four" at the appropriate location on the board:

```
LDA #04
JSR UPDATE
```

Next, we check all of the rows for the possibility of a computer win, i.e., for a total of "twelve":

```
WINTST   LDA #12
          LDY #7
```

and so on. We are now back in the main program described previously.

When the program segment outlined above is compared to the one that is used for the player's move, we find that the primary difference between the two is that the move was specified by the `ANALYZ` routine rather than being picked up from the keyboard. This routine is the key to the level of intelligence of the algorithm. Let us now examine it.

Subroutines

The ANALYZE Subroutine

The `ANALYZ` subroutine begins at line 143 of the program listing. The corresponding conceptual flowchart is shown in Figure 11.40. In the `ANALYZ` subroutine the `ODDMSK` is first set to "zero."

```
ANALYZ   LDA #0
          STA ODDMSK
```

We now check for the possibility of a computer win during its next turn. If that possibility exists, we clearly must play into the winning square. This will end the game. A winning situation is characterized by a total of "eight" in the corresponding row; therefore let us deposit the total "eight" into the accumulator:

LDA #08

A winning situation will occur when the squares in rows 1, 2, or 3 all total "three" at the same time. Let us set our filter variable, X, for the number of rows that qualify, to "three":

LDX #03

We are now ready to use the FINDMV routine:

JSR FINDMV

The FINDMV routine will be described below. It must be called with the specified ROWSUM in A and with the number of times a match is found in X. It will systematically check all of the rows and squares. If a square is found, it exits with a specified square number in X and the Z flag is set to "0." Let us test it:

BNE DONE

If a winning move has been found, the ANALYZ routine exits. Unfortunately, this is not usually the case, and more analysis must be done.

The next special situation to be checked is to see if the player has a winning move. If so, it must be blocked. A winning situation for the player is indicated by a row total of "2." Let us load "2" into the accumulator and repeat the previous process:

LDA #02
LDA #03
JSR FINDMV
BNE DONE

If the player could make a winning move, this is the square where the computer should play and we exit to DONE; otherwise, the situation should be analyzed further.

We will now check to see if the computer can implement a trap. A trap corresponds to a situation in which a computer move has already been made in the same row. We would like to play at the intersection of two rows containing computer moves. This was explained above when the algorithm was described. This situation is characterized by A = 4 and X = 2. Let us load the registers with the appropriate values

and call the FINDMV routine:

LDA #04
LDX #02
JSR FINDMV
BNE DONE

If we succeed, we exit to DONE; otherwise, we proceed down the flowchart diagrammed in Figure 11.40.

It is at this point that the computer can demonstrate either intelligent or ill-advised play. The behavior of the computer will be determined by its intelligence level. We will now obtain a random number and compare it to the computer's IQ. If the random number exceeds the computer's IQ, we will proceed to the left side of the flowchart in Figure 11.40 and make an ill-advised move (i.e., a random one). If the random number does not exceed the computer's IQ, we will make an intelligent move on the right side of the flowchart. Let us generate the random number:

JSR RANDOM

We truncate the random number to its right byte so that it does not exceed fifteen:

AND #\$0F

and we compare it to the current IQ of the computer:

CMP INTEL
BEQ OK
BCS RNDMV

If the random number is higher than the IQ level stored in INTEL, we branch to RANDMV and play a random move. At this point, we will assume that the random number was not greater than the IQ level, and that the computer will play an intelligent move. We now proceed from line 162 (location "OK").

We will first check to see if this is move #1; then we check to see if this is move #4. Let us check for move #1:

OK LPX MOVNUM
 CPX #1

If it is move #1, we occupy any square:

```
BEQ RNDMV
```

Let us now check for move #4:

```
CPX #4
```

If it is not move #4, we will check to see if the player can set a trap. This will be performed at location TRAPCK. Let us assume here that it is move #4.

```
BNE TRAPCK
```

This section will check both diagonals for the possibility of the sequence player-computer-player. If this sequence is found, we will play to the side. Otherwise, we will go back to the mainstream of this routine and check to see if the player can set a trap. The combination player-computer-player in a row is detected when the row totals "six." Therefore, we load the value "six" into the accumulator and check the corresponding diagonal. By coincidence, diagonals correspond to the sixth and seventh entries in our RWPT table. (See Figure 11.46.) Let us do it:

```
LDX #6
TXA
CMP ROWSUM,X
REQ ODDRND
```

If a match is found, we branch to address ODDRND, where we will play to the side. This will be described below. If a match is not found we check the next diagonal:

```
INX
CMP ROWSUM,X
BEQ ODDRND
```

If, at that point, the test also fails for the second diagonal, we will check to see if the player can set a trap.

Checking To See If the Player Can Set a Trap (TRAPCK)

The possibility of a trap for the player is identified (as in the case of the computer), when two intersecting rows each contain only a player's move. This has been explained in the description of the algorithm above. The value of a row which is a candidate for a trap is thereby equal to "one" (one player's move). The parameters must, therefore, be set to A = 1, and X = 2 before we can call the FINDMV routine:

```
TRAPCK LDA #1
        LDX #2
        JSR FINDMV
        BNE DONE
```

If the proper location for a trap can be found, the next move is to play there. Otherwise, if possible, the computer moves to the center or, if the center is occupied, it makes a random move on the side.

```
LDX GMBRD + 4
BNE RNDMV
LDX #5
BNE DONE
```

Playing a Random Move on the Side

The four sides on the board are numbered externally 2,4,6 and 8, or internally 1,3,5, and 7. Any odd internal number specified for a move will result in our occupying a side position. If we want to occupy a side position, we simply load the value "one" in ODDMSK, and we guarantee that the random number generated will be one of the four corners. This is performed by entering at address ODDRND:

```
ODDRND LDA #1
        STA ODDMSK
```

Generally, however, we may want to make a random move. This will be accomplished by generating and using any random number that is reasonable, i.e., by setting ODDMSK to "0" prior to entering at address RNDMV. Let us obtain a random number:

RNDMV JSR RANDOM

Let us strip off the left byte:

AND #\$0F

Then let us OR this random number with the pattern stored in ODDMSK. If the mask had been set to "0," it would have no effect on the random number. If the mask had been set to "1," however, it would result in our playing into one of the corners (the center is occupied here):

ORA ODDMSK

Since the random number which was generated was between "0" and "15," we must check to be sure that it does not exceed "9"; otherwise, it cannot be used:

CMP #9
BCS RNDMV

We must now check to make sure that the space into which we want to move is not occupied. We load the square's number into index register X and verify the square's status by reading the appropriate entry of the GMBRD table (see the memory map in Figure 11.47):

TAX
LDA GMBRD,X

If there is any entry other than "0" in this square, it means that it is occupied and we must generate another random number:

BNE RNDMV

We have selected a valid square and will now play into it. When we exit from this routine, the external LED number should be contained in X. It is obtained by adding "1" to the current contents of X, which happens to be the internal LED number:

DONE INX
RTS

FINDMV Subroutine

This subroutine will evaluate the board until it finds a square which meets the specifications in the A and the X registers. The accumulator A contains a specified row-sum that a row must meet in order to qualify. Index register X specifies the number of times that a particular square must belong to a row whose row-sum is equal to the one specified by A.

The FINDMV subroutine starts with a square status of "0" for every square on the board. Every time it finds a square that meets the row-sum specification, it will increase its status by "1." Thus, at the end of the evaluation process, a square with a status of "1" is a square which meets the row-sum specifications once. A square with a status of "2" is one that meets the specification twice, etc.

The final selection is performed by FINDMV, which checks the value of each square in turn. As soon as it finds a square whose status matches the number contained in register X, it selects that square as one that meets the initial specification.

The complete flowchart for FINDMV is shown in Figure 11.49. Essentially, the subroutine operates in three steps. These steps are indicated in Figure 11.49. Step 1 is the initialization phase. Step 2 corresponds to the selection of all squares that meet the row-sum specifications contained in register A. The status of every empty square in a row that meets this specification is increased by one as all the rows are scanned. Step 3 is the final selection phase. In this phase, each square is looked at in turn until one is found whose status matches the value contained in X. As soon as one is found, the process stops. That square is the one that will be played by the computer. If a square is not found, the routine will exit, with the index X having decremented to "0," and this will be used as a failure flag for the calling routine.

Let us now examine the corresponding program. It starts at line 204 in the program listing.

Step 1: Initialization

Index registers X and A will be used in the body of this subroutine. Their initial contents must first be preserved in temporary memory locations. Addresses TEMP1 and TEMP2 are used for that purpose. (See Figure 11.47 for the memory map.)

Let us preserve X and A:

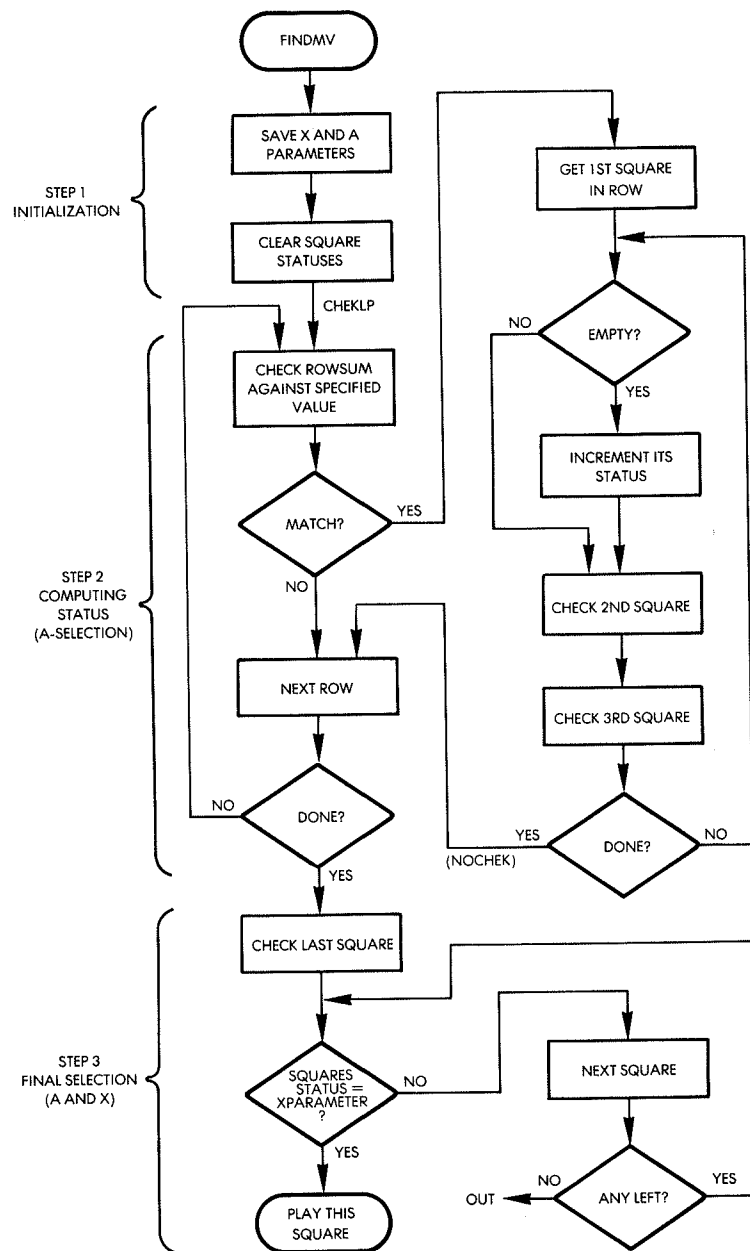

Fig. 11.49: FINDMV Flowchart

```

FINDMV   STX TEMP2
          STA TEMP1
  
```

The status of the board is then cleared. Each square's status must be set to "0." This is accomplished by loading the value "0" into the accumulator, then going through a nine cycle loop that will clear the status of each square in turn:

```

          LDA #0
          LDY #8
CLRLP    STA SQSTAT,4
          DEY
          BPL CLRLP
  
```

Step 2: Computing the Status of Each Square

Each of the eight possible row-sums will now be examined in turn. If the row-sum matches the value specified in the accumulator on entry, each empty square within the specified row will have its status incremented by "1." If the row-sum value does not meet the minimum, the next one will be examined. Index register Y is used as a row pointer. The RWPT table described at the beginning of this program and shown in Figure 11.46 will be used to successively retrieve the three squares that form every row. Let us first initialize our counter:

```
LDY #7
```

Now, we will check the value of the corresponding row-sum:

```

CHEKLP   LDA TEMP1
          CMP ROWSUM,Y
          BNE NOCHEK
  
```

Let us assume at this point that the row-sum is indeed the correct one. We must now examine each of the three squares in the row. If the square is empty, we increment its status. The first step is to obtain the square's value by looking it up in the table, using index register Y as a displacement, and using addresses RWPT1, RWPT2, and RWPT3 successively as entry points into the row table. Let us try it for the first square:

LDX RWPT1,Y

Index register X now contains the square number. If the square is empty, a new subroutine, CNTSUB, is used to increment its status:

JSR CNTSUB

It will be described below.

Let us now do the same for the second and third squares:

LDX RWPT2,Y
JSR CNTSUB
LDX RWPT3,Y
JSR CNTSUB

We have now completely scanned one row. Let us look to see if any more rows need to be checked:

NOCHEK DEY
BPL CHECKLP

The process is repeated until all the rows have been checked. At this point, we enter into step 3 of FINDMV. (Refer to the flowchart in Figure 11.49.)

Step 3: Final Selection

Index register X will be used as a square pointer. It will start with square #9 and continue to examine squares until one is found that meets the additional X register specifications, i.e., the number of times that the given square belongs to a row with the appropriate row-sum value. Let us initialize it:

LDX #9

Now, we compare the value of the square status with the value of the specified X parameter:

FNMTCH LDA TEMP2
AND SQSTAT-1,X

If the square status matches the value of the parameter, we select this square:

BNE FOUND

Otherwise, we try the next one:

DEX
BNE FNMTCH
FOUND RTS

Exercise 11-5: Why are "AND" and "BNE" rather than "CMP" and "BEQ" used to find a matching square above? (Hint: decide what the difference in the program's strategy would be.)

COUNTSUB Subroutine

This subroutine is used exclusively by the FINDMV subroutine and increments the status of the square whose number is in register X, if the square is empty. First, it examines the status of the square by looking for its code in the GMBRD table:

CNTSUB LDA GMBRD,X
BNE NOCNT

If the square is occupied, an exit occurs. If it is not, the status value of the square is incremented:

NOCNT INC SQSTAT,X
RTS

UPDATE Subroutine

Every time a move is made, it must be displayed on the board. Then, the appropriate code must be stored in the board representation, i.e., in the table GMBRD. Finally, the new ROWSUMs must be computed and stored at the appropriate locations. These functions are accomplished by the UPDATE subroutine.

The player's code is contained in the accumulator. The position into which the move is made is contained in register X. Since the number in index register X is the value of an external LED, it is first decremented in order to match the actual internal LED number:

UPDATE DEX

The value must now be stored in the appropriate location of the GMBRD table which contains the internal representation of the board:

STA GMBRD,X

Note that the value of X is simply used as a displacement into the table. However, the accumulator happens to contain the appropriate code that is merely written at the specified location. At this point, UPDATE would like to display the move on the LEDs. It must first decide, however, whether to light a steady LED or make it blink. To do this, it must determine whether it is the player's move or the computer's move. It does this by examining the code contained in the accumulator. If the code is "four," it is the computer's move. If the code is "1," it is the player's move. Let us examine it:

CMP #04
BEQ NOBLNK

If it is the computer's move, a branch will occur to address NOBLNK; otherwise, we proceed. Let us assume for the time being that it was the player's move:

JSR LIGHT

The LIGHT subroutine is used to set the bit blinking and will be described below. Upon exit from LIGHT, the accumulator contains the bit in the position that is required to set the LED blinking. At this point, the blink masks should be updated:

ORA LTMSKL
STA LTMSKL

If the carry was "zero" upon completion of LIGHT, one of the bits zero through seven had been set and we are done:

BCC NOBLNK

Otherwise, if the carry had been set to 1, it would mean that LED #9 had to be set, i.e., that the high order part of the mask had to be

modified. Let us do it:

LDA #01
STA LTMSKH

At this point, the LED masks are properly configured and we can give the order to light the LEDs:

NOBLNK JSR LEDLTR

The LEDLTR routine lights up the LED specified by register X. Note that if it was a computer move, this LED will remain steadily on. If it was a player's move, this LED will be turned off and on automatically as interrupts occur.

Next, we must update all row-sums. Index register X is used as a row pointer. We will look at all eight rows in turn. In anticipation of the addition, the carry bit is cleared:

LDX #7
ADDROW CLC

The first square of row eight is examined first:

LDY RWPT1,X

Note that index register Y will contain the internal square number following this instruction. This will immediately be used for another indexed operation. The contents of the square will be read so that the new row-sum may be computed. (The row-sum for that row may or may not be the same as before. No special provision has been made for restricting the search to the two or three rows affected.) All rows are examined in turn, and all row-sums are re-computed to keep the program simple.

Let us obtain the current square's value:

LDA GMBRD,Y

The GMBRD table is accessed using index register Y as a displacement. Note that the two instructions shown above implement a two-level indexing operation. This is a most efficient data retrieval technique. At this point, the accumulator contains the value of the first

square. It will be added to the value of the two following squares. The process will now be repeated:

```
LDY RWPT2,X
ADC GMBRD,Y
```

The number of the second square has been looked up by the LDY instruction and its value stored in Y. The addition instruction looks up the actual value of that square from GMBRD, and adds that value to the accumulator. This process is performed one more time for the third square:

```
LDY RWPT3,X
ADC GMBRD,Y
```

The final value contained in the accumulator is then stored in the ROWSUM table at the position specified by the value of index register X (the row index):

```
STA ROWSUM,X
```

The next row will now be scanned:

```
DEX
BPL ADDROW
```

If X becomes negative, we are done:

```
RTS
```

LED LIGHTER Subroutine

This subroutine assumes upon entry that register X contains the internal LED number of the LED on the board which must be turned on. The subroutine will therefore turn that LED on using the LIGHT subroutine, which converts a number in register X into a bit pattern in the accumulator for the purpose of turning on the specified LED:

```
LEDLTR JSR LIGHT
```

At this point, either Port 1A or Port 1B must be updated. Let us

assume initially that it is Port 1A (if it is not Port 1A, which we can find out by examining the carry bit below, then the pattern contained in the accumulator is all zeroes and will not change the value of Port 1A):

```
ORA PORT1A
STA PORT1A
BCC LTRDN
```

The carry bit is tested. If it has been set to 1 by the LIGHT subroutine, then LED #9 must be turned on. This is accomplished by sending a "1" to Port 1B:

```
LDA #1
STA PORTB
RTS
```

PLRMV Subroutine (Player's Move)

This subroutine obtains one correct move from the player. It chirps to get his or her attention and waits for a keyboard input. If a key other than 1 through 9 is pressed, it will be ignored. Whenever the subroutine gets a move, it verifies that the square on the board is indeed empty. If the square is not empty, the subroutine will ignore the player's move. Let us first generate a chirp in order to get the player's attention:

```
PLRMV LDA #$80
STA DUR
LDA #$10
JSR TONE
```

Now, let us capture the key closure:

```
KEYIN JSR GETKEY
```

We must now check to see that the key that is pressed is between 1 and 9. Let us first check to see that it is not greater than or equal to 10:

```
CMP #10
BCS KEYIN
```

Let us now verify that it is not equal to "zero":

```
TAX
BEQ KEYIN
```

Finally, let us verify that it does not correspond to a square that is already occupied:

```
LDA GMBRD-1,X
BNE KEYIN
RTS
```

Exercise 11-6: *Modify the PLRMV subroutine above so that a new chirp is generated every time a player makes an incorrect move. To tell the player that he or she has made an incorrect move, you should generate a sequence of two chirps, using a different tone than the one used previously.*

LIGHT Subroutine

This subroutine accepts an LED number in register X. It returns with the pattern to be output to the LEDs in the accumulator. If LED 9 is to be lit ($X = 8$), the carry bit is set. This subroutine is straightforward and has been described previously:

```
LIGHT      STX TEMP1
           SEC
           ROL A
           DEX
           BPL SHIFT
           LDX TEMP1
           RTS
```

DELAY Subroutine

This is a classic delay subroutine that uses two nested loops that have a few extra instructions within the loop that are designed to waste time:

```
DELAY      LDY #$FF
DL1        LDX #$FF
DL2        ROL DUR
           ROR DUR
```

```
DEX
BNE DL2
DEY
BNE DL1
RTS
```

Interrupt Handling Routine

Every time that an interrupt is received, the appropriate LEDs will be complemented (turned off if on, or on if off). The positions of the LEDs to be blinked are specified by the contents of the LTMSK masks. Two bytes are used in memory for the low and high halves, respectively. (See Figure 11.47 for the memory map.)

Turning the bits on or off is accomplished by an exclusive-OR instruction that is the equivalent of a logical complementation. Since this routine uses the accumulator, the contents of A must be preserved at the beginning of the routine. It is pushed onto the stack and restored upon exit. The subroutine is shown below:

```
INTVEC     PHA
           LDA PORT1A
           EOR LTMSKL
           STA PORT1A
           LDA PORT1B
           EOR LTMSKH
           STA PORT1B
           LDA TILL
           PLA
           RTI
```

Exercise 11-7: *Notice the LDA TILL instruction above. The next instruction in this subroutine is PLA. It will overwrite the contents of the accumulator with the words pulled from the stack. The contents of the accumulator, as read from TILL, will therefore be immediately destroyed. Is this a programming error that was accidentally left in this program? If not, what purpose does it serve? (Hint: this situation has been encountered before. Refer to one of the earlier chapters.)*

INITIALIZE Subroutine

This subroutine was described in the body of the main program above.

RANDOM and TONE Subroutines

These two subroutines were described in previous programs.

SUMMARY

This program was the most complex we have developed. Several algorithms have been presented, and one complete implementation of an *ad hoc* algorithm has been studied in great detail. Readers interested in games of strategy and programming are encouraged to implement an alternative algorithm.

| LINE # | LOC | CODE | LINE |
|--------|------|------|--|
| 0002 | 0000 | | ; 'TICTAC' |
| 0003 | 0000 | | ; PROGRAM TO PLAY TIC-TAC-TOE ON SYM-1 |
| 0004 | 0000 | | ; COMPUTER WITH 3X3 LED MATRIX AND HEX KYBD. |
| 0005 | 0000 | | ; AT BEGINNING OF GAME, IF 'F' KEY IS |
| 0006 | 0000 | | ; PRESSED, PLAYER GOES FIRST, ANY OTHER KEY, |
| 0007 | 0000 | | ; COMPUTER GOES FIRST. THEREAFTER, TO MAKE |
| 0008 | 0000 | | ; A MOVE, PRESS KEY CORRESPONDING TO NUMBER |
| 0009 | 0000 | | ; OF SQUARE DESIRED. |
| 0010 | 0000 | | ; |
| 0011 | 0000 | | ; LINKAGES: |
| 0012 | 0000 | | ; |
| 0013 | 0000 | | GETKEY = \$100 |
| 0014 | 0000 | | ACCESS = \$8B86 |
| 0015 | 0000 | | ; |
| 0016 | 0000 | | ; I/O: |
| 0017 | 0000 | | ; |
| 0018 | 0000 | | PORT1A = \$A001 ;** 6522 VIA #1.... |
| 0019 | 0000 | | DDR1A = \$A003 |
| 0020 | 0000 | | PORT1B = \$A000 |
| 0021 | 0000 | | DDR1B = \$A002 |
| 0022 | 0000 | | IER = \$A00E ; INTERRUPT ENABLE REGISTER. |
| 0023 | 0000 | | ACR = \$A00B ; AUXILIARY CONTROL REGISTER. |
| 0024 | 0000 | | T1LL = \$A004 ; TIMER 1 LATCH LOW. |
| 0025 | 0000 | | T1CH = \$A005 ; TIMER 1 LATCH HIGH. |
| 0026 | 0000 | | PORT3B = \$AC00 ;**6522 VIA #3.... |
| 0027 | 0000 | | DDR3B = \$AC02 |
| 0028 | 0000 | | IRQVL = \$A67E |
| 0029 | 0000 | | IRQVH = \$A67F |
| 0030 | 0000 | | ; |
| 0031 | 0000 | | ; TABLE OF SQUARES IN BOARD'S 8 ROWS. |
| 0032 | 0000 | | ; |
| 0033 | 0000 | | ; * = 0 |
| 0034 | 0000 | | ; |
| 0035 | 0000 | 00 | RWPT1 .BYTE 0,1,2,0,3,6,0,2 |
| 0035 | 0001 | 01 | |
| 0035 | 0002 | 02 | |
| 0035 | 0003 | 00 | |
| 0035 | 0004 | 03 | |
| 0035 | 0005 | 06 | |
| 0035 | 0006 | 00 | |
| 0035 | 0007 | 02 | |
| 0036 | 0008 | 03 | RWPT2 .BYTE 3,4,5,1,4,7,4,4 |
| 0036 | 0009 | 04 | |
| 0036 | 000A | 05 | |
| 0036 | 000B | 01 | |
| 0036 | 000C | 04 | |
| 0036 | 000D | 07 | |
| 0036 | 000E | 04 | |
| 0036 | 000F | 04 | |
| 0037 | 0010 | 06 | RWPT3 .BYTE 6,7,8,2,5,8,8,6 |

Fig. 11.50: Tic-Tac-Toe Program

| | | | |
|------|------|----------|---|
| 0037 | 0011 | 07 | |
| 0037 | 0012 | 08 | |
| 0037 | 0013 | 02 | |
| 0037 | 0014 | 05 | |
| 0037 | 0015 | 08 | |
| 0037 | 0016 | 08 | |
| 0037 | 0017 | 06 | |
| 0038 | 0018 | | ; |
| 0039 | 0018 | | ; VARIABLE STORAGES: |
| 0040 | 0018 | | ; |
| 0041 | 0018 | | CLRST ;1ST LOC. TO BE CLEARED BY 'INIT'. |
| 0042 | 0018 | | GMRD **\$+9 ;GAME BOARD; PLAYER'S POSITIONS ON |
| 0043 | 0021 | | ; BOARD AS #01=COMPUTER, #04=PLAYER. |
| 0044 | 0021 | | SQSTAT **\$+9 ;SQUARE'S TACTICAL STATUS. |
| 0045 | 002A | | ROWSUM **\$+8 ;SUM OF VALUES OF SQUARES IN |
| 0046 | 0032 | | ; ROW, WHERE 1=PLAYER, |
| 0047 | 0032 | | ; 4=COMPUTER, 0=EMPTY. |
| 0048 | 0032 | | RNDSCR **\$+6 ;RND # GEN. SCRATCHPAD. |
| 0049 | 003B | | TEMP1 **\$+1 |
| 0050 | 0039 | | TEMP2 **\$+1 |
| 0051 | 003A | | MOVNUM **\$+1 ;NUMBER OF CURRENT MOVE. |
| 0052 | 003B | | PLAYR **\$+1 ;WHO'S TURN IT IS. |
| 0053 | 003C | | LTMSKH **\$+1 ;HIGH ORDER BLINK MASK FOR LED'S |
| 0054 | 003D | | LTMSKL **\$+1 ;LOW ORDER SAME. |
| 0055 | 003E | | DUR **\$+1 ;DURATION FOR TONES. |
| 0056 | 003F | | FREQ **\$+1 ;FREQUENCY OF TONES. |
| 0057 | 0040 | | CLREND ;LAST LOC TO BE CLEARED BY 'INIT'. |
| 0058 | 0040 | | ODDMASK **\$+1 ;MAKES PRODUCT OF RANDOM MOVE |
| 0059 | 0041 | | ; GENERATOR ODD TO PICK CORNER. |
| 0060 | 0041 | | INTEL **\$+1 ;INTELLIGENCE QUOTIENT. |
| 0061 | 0042 | | ; |
| 0062 | 0042 | | ; ***** MAIN PROGRAM ***** |
| 0063 | 0042 | | ; |
| 0064 | 0042 | | ; * = \$200 |
| 0065 | 0200 | | ; |
| 0066 | 0200 | A9 0C | START LDA #12 |
| 0067 | 0202 | 85 41 | STA INTEL ;SET I.Q. AT 75% |
| 0068 | 0204 | 20 50 00 | RESTR JSR INIT ;INITIALIZE PROGRAM. |
| 0069 | 0207 | 20 00 01 | JSR GETKEY ;GET FIRST MOVE DETERMINER. |
| 0070 | 020A | C9 0F | CMF #\$F ;IS IT 'F'? |
| 0071 | 020C | D0 04 | BNE PLAYLP |
| 0072 | 020E | A9 01 | LDA #01 ;YES, PLAYER FIRST. |
| 0073 | 0210 | 85 3B | STA PLAYR |
| 0074 | 0212 | E6 3A | PLAYLP INC MOVNUM ;COUNT THE MOVES. |
| 0075 | 0214 | A5 3B | LDA PLAYR ;WHO'S TURN? |
| 0076 | 0216 | F0 0E | BEQ COMPMV ;IF 0, COMPUTER'S MOVE. |
| 0077 | 0218 | C6 3B | DEC PLAYR ;PLAYER'S TURN, COMPUTER NEXT. |
| 0078 | 021A | 20 80 03 | JSR PLRMV ;GET PLAYER'S MOVE. |
| 0079 | 021D | A9 01 | LDA #01 ;STORE PLAYER'S PIECE. |
| 0080 | 021F | 20 40 03 | JSR UPDATE ;PLAY IT, AND UPDATE ROWSUMS. |
| 0081 | 0222 | A9 03 | LDA #03 ;LOAD PATTERN FOR WIN SEARCH. |
| 0082 | 0224 | D0 0F | BNE WINTST ;CHECK FOR WIN. |
| 0083 | 0226 | E6 3B | COMPMV INC PLAYR ;COMPUTER'S TURN, PLAYER NEXT. |
| 0084 | 0228 | 20 A4 03 | JSR DELAY ;TIME FOR COMPUTER TO 'THINK'. |
| 0085 | 022B | 20 9D 02 | JSR ANALYZ ;FIND COMPUTER'S MOVE. |
| 0086 | 022E | A9 04 | LDA #04 ;STORE COMPUTER'S PIECE. |
| 0087 | 0230 | 20 40 03 | JSR UPDATE ;PLAY IT. |
| 0088 | 0233 | A9 0C | LDA #12 ;LOAD PATTERN FOR WIN SEARCH. |
| 0089 | 0235 | A0 07 | WINTST LDY #7 ;LOOP 7X TO CHECK ROWSUMS |
| 0090 | 0237 | D9 2A 00 | TSTLP CMP ROWSUM,Y ;FOR WINNING PATTERN. |
| 0091 | 023A | F0 11 | BEQ WIN ;WIN IF PATTERN FOUND. |
| 0092 | 023C | 88 | DEY ;LOOP AND |
| 0093 | 023D | 10 F8 | BPL TSTLP ;TRY AGAIN. |
| 0094 | 023F | A5 3A | LDA MOVNUM ;IF MOVE NUMBER = 9, |
| 0095 | 0241 | C9 09 | CMF #9 ;THEN GAME IS TIE. |
| 0096 | 0243 | D0 CD | BNE PLAYLP ;KEEP PLAYING IF NOT. |
| 0097 | 0245 | A9 FF | LDA #\$FF ;SET ALL LIGHTS TO BLINKING. |
| 0098 | 0247 | 85 3D | STA LTMSKL |
| 0099 | 0249 | 85 3C | STA LTMSKH |
| 0100 | 024B | D0 4A | BNE DLY ;KEEP THEM BLINKING A WHILE. |
| 0101 | 024D | C9 0C | WIN CMF #12 ;COMPUTER WIN? |
| 0102 | 024F | F0 0E | BEQ INTDN ;IF YES, I.Q. DOWN. |

Fig. 11.50: Tic-Tac-Toe Program (Continued)

```

0103 0251 A9 1E      LDA #30      ;LOAD FREQ. CONST FOR WIN TONE.
0104 0253 85 3F      STA FREQ
0105 0255 A5 41      LDA INTEL
0106 0257 C9 0F      CMP #0F      ;I.O. AS HIGH AS POSSIBLE?
0107 0259 F0 0E      BEQ GTMSK   ;IF YES, DON'T CHANGE IT.
0108 025B E6 41      INC INTEL   ;RAISE I.O.
0109 025D D0 0A      BNE GTMSK   ;GO FLASH ROW.
0110 025F A9 FF      INTDN LDA #FF  ;LOAD FREQ. CONST. FOR LOSE TONE.
0111 0261 85 3F      STA FREQ
0112 0263 A5 41      LDA INTEL   ;I.O. = 0?
0113 0265 F0 02      BEQ GTMSK   ;IF YES, DON'T DECREMENT!
0114 0267 C6 41      DEC INTEL   ;I.O. DOWN.
0115 0269 A9 00      GTMSK LDA #0    ;CLEAR ALL LEAS.
0116 026B 8D 01 A0    STA PORT1A
0117 026E 8D 00 A0    STA PORT1B
0118 0271 B6 00      LDX RWPT1,Y ;GET BIT IN ACCUM. TO LIGHT
0119 0273              ;LED CORRESPONDING TO 1ST SQUARE
0120 0273              ;IN WINNING ROW.
0121 0273 20 6F 03    JSR LEDLTR
0122 0276 B6 08      LDX RWPT2,Y ;GET SECOND BIT.
0123 0278 20 6F 03    JSR LEDLTR
0124 027B B6 10      LDX RWPT3,Y ;GET 3RD BIT.
0125 027D 20 6F 03    JSR LEDLTR
0126 0280 AD 01 A0    LDA PORT1A ;MASK OUT UNNECESSARY BITS IN
0127 0283 25 3D      AND LTMSKL ;BLINK MASKS.
0128 0285 85 3D      STA LTMSKL
0129 0287 AD 00 A0    LDA PORT1B
0130 028A 25 3C      AND LTMSKH
0131 028C 85 3C      STA LTMSKH
0132 028E A9 FF      LDA #FF     ;SET WIN/LOSE TONE DURATION.
0133 0290 85 3E      STA DUR
0134 0292 A5 3F      LDA FREQ    ;GET FREQUENCY.
0135 0294 20 AD 00    JSR TONE    ;PLAY TONE.
0136 0297 20 A4 03    DLY JSR DELAY ;DELAY TO SHOW WIN OR TIE.
0137 029A 4C 04 02    JMP RESTRT ;START NEW GAME, DON'T CHNG. I.O.
0138 029D              ;
0139 029D              ; ***** SUBROUTINE 'ANALYZE' *****
0140 029D              ; DOES A STATIC ANALYSIS OF GAME BOARD, AND
0141 029D              ; RETURNS WITH A MOVE IN REGISTER X.
0142 029D              ;
0143 029D A9 00      ANALYZ LDA #0 ;SET MASK THAT MAKES RANDOM MOVES
0144 029F 85 40      STA ODDMSK ;RE SIDES TO 0.
0145 02A1 A9 08      LDA #08     ;CHECK FOR WINNING MOVE FOR
0146 02A3 A2 03      LDX #03     ;COMPUTER.
0147 02A5 20 04 03    JSR FINDMV
0148 02A8 D0 59      BNE DONE    ;IF FOUND, RETURN.
0149 02AA A9 02      LDA #02     ;CHECK FOR WINNING MOVE FOR
0150 02AC A2 03      LDX #03     ;PLAYER.
0151 02AE 20 04 03    JSR FINDMV
0152 02B1 D0 50      BNE DONE    ;IF FOUND, RETURN.
0153 02B3 A9 04      LDA #04     ;CAN COMPUTER SET A TRAP?
0154 02B5 A2 02      LDX #02
0155 02B7 20 04 03    JSR FINDMV
0156 02BA D0 47      BNE DONE    ;IF YES, PLAY IT.
0157 02BC 20 9A 00    JSR RANDOM ;GET A RANDOM NUMBER...
0158 02BF 29 0F      AND #0F     ;...AND MAKE IT 0-15...
0159 02C1 C5 41      CMP INTEL   ;FOR USE AS STUPID/SMART DETERMINER.
0160 02C3 F0 02      BEQ OK      ;IF BOTH ARE EQUAL, SKIP TEST
0161 02C5 B0 2B      BCS RNDMV   ;IF RND# > INTEL, PLAY A DUMB MOVE.
0162 02C7 A6 3A      OK LDX MOVNUM
0163 02C9 E0 01      CPX #1      ;1ST MOVE?
0164 02CB F0 25      BEQ RNDMV   ;IF YES, PLAY ANY SQUARE.
0165 02CD E0 04      CPX #4      ;4TH MOVE?
0166 02CF D0 0C      BNE TRAPCK ;IF NOT, CONTINUE.
0167 02D1 A2 06      LDX #6      ;LOAD INDEX TO 1ST DIAG. ROWSUM.
0168 02D3 BA          TXA          ;LOAD SUM OF ROW HAVING P-C-P.
0169 02D4 B5 2A      CMP ROWSUM,X ;CHECK IF 1ST DIAG. IS P-C-P
0170 02D6 F0 14      BEQ ODDRND ;IF YES, PLAY SIDE.
0171 02D8 EB          INX          ;CHECK NEXT DIAG. ROWSUM
0172 02D9 B5 2A      CMP ROWSUM,X
0173 02DB F0 11      BEQ ODDRND
0174 02DD A9 01      TRAPCK LDA #1 ;CAN PLAYER SET A TRAP?

```

Fig. 11.50: Tic-Tac-Toe Program (Continued)

```

0175 02DF A2 02      LDX #2
0176 02E1 20 04 03    JSR FINDMV
0177 02E4 D0 1D      BNE DONE
0178 02E6 A6 1C      LDX GMBRD+4 ;IF YES, PLAY BLOCK.
0179 02E8 D0 08      BNE RNDMV   ;IS CENTER
0180 02EA A2 05      LDX #5      ;OCCUPIED?
0181 02EC D0 15      BNE DONE    ;NO: PLAY IT.
0182 02EE A9 01      ODDRND LDA #1 ;SET ODDMASK TO 1, SO
0183 02F0 85 40      STA ODDMSK ;MOVE WILL BE A SIDE.
0184 02F2 20 9A 00    RNDMV JSR RANDOM ;GET RANDOM # FOR MOVE.
0185 02F5 29 0F      AND #0F     ;MAKE IT 0-15.
0186 02F7 05 40      ORA ODDMSK ;MAKE ODD # IF CORNER NEEDED.
0187 02F9 C9 09      CMP #9      ;NUMBER TOO HIGH?
0188 02FB B0 F5      BCS RNDMV   ;IF YES, GET ANOTHER.
0189 02FD AA          TAX
0190 02FE B5 18      LDA GMBRD,X ;SPACE OCCUPIED?
0191 0300 D0 F0      BNE RNDMV   ;IF YES, GET ANOTHER MOVE.
0192 0302 EB          INX          ;INCREMENT X TO MATCH OUTPUT OF FINDMV.
0193 0303 60          DONE RTS     ;RETURN W/ MOVE IN X.
0194 0304              ;
0195 0304              ; ***** SUBROUTINE 'FIND MOVE' *****
0196 0304              ; FINDS A SQUARE MEETING SPECIFICATIONS
0197 0304              ; PASSED IN IN A AND X.
0198 0304              ; INDEX REGISTER X CONTAINS
0199 0304              ; MASK THAT, WHEN OR'ED WITH
0200 0304              ; NUMBER OF TIMES A SQUARE FITS ROWS WITH
0201 0304              ; ROWSUM IN ACCUM., MUST YIELD A ONE
0202 0304              ; FOR SQUARE TO QUALIFY.
0203 0304              ;
0204 0304 86 39      FINDMV STX TEMP2 ;SAVE REGISTERS.
0205 0306 85 38      STA TEMP1
0206 0308 A9 00      LDA #0      ;CLEAR SQUARE STATUS REGISTERS.
0207 030A A0 08      LDY #8
0208 030C 99 21 00    CLRLP STA SQSTAT,Y
0209 030F 88          DEY
0210 0310 10 FA      BPL CLRLP
0211 0312 A0 07      LDY #7
0212 0314 A5 38      CHECKP LDA TEMP1 ;LOOP 7X
0213 0316 D9 2A 00    CMP ROWSUM,Y ;DOES ROWSUM
0214 0319 D0 0F      BNE NOCHECK ;MATCH PARAMETER?
0215 031B B6 00      LDX RWPT1,Y ;IF NOT, TRY NEXT.
0216 031D 20 39 03    JSR CNTSUB ;CHECK 1ST SQUARE IN ROW.
0217 0320 B6 08      LDX RWPT2,Y ;INCREMENT ITS STATUS IF IT'S EMPTY.
0218 0322 20 39 03    JSR CNTSUB ;DO 2ND SQUARE.
0219 0325 B6 10      LDX RWPT3,Y ;AND THIRD.
0220 0327 20 39 03    JSR CNTSUB
0221 032A 88          NOCHECK BEY ;TRY NEXT ROW.
0222 032B 10 E7      BPL CHECKP
0223 032D A2 09      LDY #9
0224 032F A5 39      FNMTCH LDA TEMP2 ;LOAD PARAMETER...
0225 0331 35 20      AND SQSTAT-1,X ;(SQUARE STATUS)AND(PARAM)>0?
0226 0333 D0 03      BNE FOUND   ;IF YES, PLAY X AS MOVE.
0227 0335 CA          DEX          ;DECREMENT AND TRY NEXT SQSTAT.
0228 0336 D0 F7      BNE FNMTCH
0229 0338 60          FOUND RTS
0230 0339              ;
0231 0339              ; ***** SUBROUTINE 'COUNTS' *****
0232 0339              ; INCREMENTS SQSTAT OF EMPTY SQUARES.
0233 0339              ;
0234 0339 B5 18      CNTSUB LDA GMBRD,X ;GET SQUARE.
0235 033B D0 02      BNE NOCNT   ;IF FULL, SKIP.
0236 033D F6 21      INC SQSTAT,X ;INCREMENT SQSTAT
0237 033F 60          NOCNT RTS   ;DONE.
0238 0340              ;
0239 0340              ; ***** SUBROUTINE 'UPDATE' *****
0240 0340              ; PLAYS MOVE BY STORING CODE PASSED IN IN ACCUM.
0241 0340              ; AT SQUARE SPECIFIED BY X REG.
0242 0340              ; ALSO LIGHTS/SETS BLINKING PROPER LED,
0243 0340              ; AND COMPUTES ROWSUMS.
0244 0340              ;
0245 0340 CA          UPDATE DEX   ;DECREMENT MOVE TO MATCH INDEXING.
0246 0341 95 18      STA GMBRD,X ;PLAY MOVE.

```

Fig. 11.50: Tic-Tac-Toe Program (Continued)

```

0247 0343 C9 04      CMP #04      ;COMPUTER'S MOVE?
0248 0345 F0 0D      BEQ NOBLNK  ;IF YES, DON'T SET LED BLINKING.
0249 0347 20 98 03   JSR LIGHT  ;PLAYER'S MOVE;GET BIT CORRESPONDING
0250 034A           ;TO LED TO BE SET TO BLINKING.
0251 034A 05 3D      ORA LTMSKL ;PLACE BIT IN BLINK MASKS.
0252 034C 85 3D      STA LTMSKL
0253 034E 90 04      BCC NOBLNK ;IF C=0, DON'T SET BIT 9.
0254 0350 A9 01      LDA #01    ;SET BIT 9 TO BLINKING.
0255 0352 85 3C      STA LTMSKH
0256 0354 20 6F 03   NOBLNK JSR LEDLTR ;LIGHT LED.
0257 0357 A2 07      LDX #7     ;LOOP TO COMPUTE ROWSUMS.
0258 0359 18         ADDROW CLC ;PREPARE FOR ADDITION.
0259 035A B4 00      LDY RWFT1,X ;GET FIRST SQUARE ADDRESS.
0260 035C B9 18 00   LDA GMRD,Y ;GET CONTENTS OF SQUARE.
0261 035F B4 08      LDY RWFT2,X ;ADD SECOND SQUARE IN ROW.
0262 0361 79 18 00   ADC GMRD,Y
0263 0364 B4 10      LDY RWFT3,X ;ADD FINAL SQUARE.
0264 0366 79 18 00   ADC GMRD,Y
0265 0369 95 2A      STA ROWSUM,X ;SAVE ROWSUM
0266 036B CA        DEX
0267 036C 10 EB      BPL ADDROW ;GET NEXT ROWSUM.
0268 036E 60        RTS
0269 036F           ;
0270 036F           ; ***** SUBROUTINE 'LED LIGHTER' *****
0271 036F           ; GIVEN AN ARGUMENT IN X REG, LIGHTS
0272 036F           ; LED (0-8) CORRESPONDING TO THAT ARGUMENT.
0273 036F           ;
0274 036F 20 98 03   LEDLTR JSR LIGHT ;GET BIT IN CORRECT POSITION.
0275 0372 0D 01 A0   ORA PORT1A ;LIGHT LED.
0276 0375 8D 01 A0   STA PORT1A
0277 0378 90 05      BCC LTRDN  ;IF LED #9 NOT TO BE LIT; SKIP.
0278 037A A9 01      LDA #1    ;LIGHT LED #9
0279 037C 8D 00 A0   STA PORT1B ;DONE.
0280 037F 60        LTRDN RTS
0281 0380           ;
0282 0380           ; ***** SUBROUTINE 'PLAYER'S MOVE' *****
0283 0380           ; GETS PLAYER'S MOVE; CHECKS FOR ERRORS.
0284 0380           ;
0285 0380 A9 80      PLRMV LDA #80   ;MAKE SHORT BEEP TO SIGNAL
0286 0382 85 3E      STA DUR   ;KEYBOARD INPUT NEEDED.
0287 0384 A9 10      LDA #10
0288 0386 20 AD 00   JSR TONE
0289 0389 20 00 01   KEYIN JSR GETKEY ;GET MOVE.
0290 038C C9 0A      CMP #10   ;OUT OF BOUNDS?
0291 038E B0 F9      BCS KEYIN ;IF YES, GET ANOTHER.
0292 0390 AA        TAX
0293 0391 F0 F6      BEQ KEYIN ;IF MOVE = 0, GET ANOTHER.
0294 0393 B5 17      LDA GMRD-1,X ;SQUARE EMPTY?
0295 0395 D0 F2      BNE KEYIN ;IF NOT, TRY AGAIN.
0296 0397 60        RTS
0297 0398           ;
0298 0398           ; ***** SUBROUTINE 'LIGHT' *****
0299 0398           ; SHIFTS A ONE BIT LEFT IN ACCUMULATOR TO
0300 0398           ; A POSITION CORRESPONDING TO THE
0301 0398           ; ARGUMENT PASSED IN IN REG. X. IF X=9,
0302 0398           ; CARRY IS SET.
0303 0398           ;
0304 0398 86 38      LIGHT STX TEMP1 ;SAVE X.
0305 039A A9 00      LDA #0    ;CLEAR ACCUM. FOR SHIFT.
0306 039C 38        SEC      ;GET BIT TO BE SHIFTED.
0307 039D 2A        SHIFT ROL A  ;SHIFT BIT LEFT.
0308 039E CA        DEX
0309 039F 10 FC      BPL SHIFT ;COUNT DOWN AND LOOP.
0310 03A1 A6 38      LDX TEMP1 ;RESTORE X.
0311 03A3 60        RTS
0312 03A4           ;
0313 03A4           ; ***** SUBROUTINE 'DELAY' *****
0314 03A4           ;
0315 03A4 A0 FF      DELAY LDY #FF
0316 03A6 A2 FF      DLI  LDX #FFF
0317 03A8 26 3E      DLI2  ROL DUR ;WASTE TIME.
0318 03AA 66 3E      ROR DUR

```

Fig. 11.50: Tic-Tac-Toe Program (Continued)

```

0319 03AC CA        DEX
0320 03AD D0 F9      BNE DL2
0321 03AF 88        DEY
0322 03B0 D0 F4      BNE DL1
0323 03B2 60        RTS
0324 03B3           ;
0325 03B3           ; ***** INTERRUPT HANDLING ROUTINE *****
0326 03B3           ; AT EACH INTERRUPT, LEDS WHOSE POSITIONS IN
0327 03B3           ; THE BLINK MASKS HAVE ONES IN THEM ARE TURNED
0328 03B3           ; ON IF OFF, OFF IF ON.
0329 03B3 48        INTVEC PHA
0330 03B4 AD 01 A0   LDA PORT1A
0331 03B7 45 3D      EOR LTMSKL
0332 03B9 8D 01 A0   STA PORT1A
0333 03BC AD 00 A0   LDA PORT1B
0334 03BF 45 3C      EOR LTMSKH
0335 03C1 8D 00 A0   STA PORT1B
0336 03C4 AD 04 A0   LDA TILL
0337 03C7 68        PLA
0338 03C8 40        RTI
0339 03C9           ;
0340 03C9           ; ***** SUBROUTINE 'INITIALIZE' *****
0341 03C9           ; INITIALIZES PROGRAM.
0342 03C9           ;
0343 03C9           ; * = #50
0344 03D0           ;
0345 03D0 A9 00      INIT  LDA #0    ;CLEAR STORAGES.
0346 03D2 A2 28      LDX #CLREND-CLRST
0347 03D4 95 18      CLRALL STA CLRST,X
0348 03D6 CA        DEX
0349 03D7 10 FB      BPL CLRALL
0350 03D9 AD 04 A0   LDA TILL ;GET RANDOM NUMBER GENERATOR SEED.
0351 03DB 85 33      STA RNDSR+1
0352 03DE 85 36      STA RNDSR+4
0353 03E0 A9 FF      LDA #FF
0354 03E2 8D 03 A0   STA DDR1A ;SET UP I/O
0355 03E5 8D 02 A0   STA DDR1B
0356 03E8 8D 02 AC   STA DDR3B
0357 03EA A9 00      LDA #0    ;CLEAR LEDES
0358 03EB 8D 01 A0   STA PORT1A
0359 03ED 8D 00 A0   STA PORT1B
0360 03EF           ;SET UP TIMER FOR INTERRUPTS WHICH
0361 03F3           ;BLINK LEDES.
0362 03F3 20 86 8B   JSR ACCESS ;UNPROTECT SYM-1 SYSTEM MEMORY TO
0363 03F6 00 76      ;SET UP INTERRUPT VECTORS.
0364 03F8 A9 B3      LDA #<INTVEC ;LOAD LOW BYTE INTERRUPT VECTOR.
0365 03FB 8D 7E A6   STA IRQUL ;STORE AT INTERRUPT VECTOR LOCATION.
0366 03FD A9 03      LDA #>INTVEC ;LOAD HI BYTE INTERRUPT VECTOR.
0367 03FF 8D 7F A6   STA IRQVH ;STORE.
0368 0400 A9 7F      LDA #7F   ;CLEAR INTERRUPT ENABLE REGISTER.
0369 0402 8D 0E A0   STA IER
0370 0405 A9 C0      LDA #C0   ;ENABLE TIMER1 INTERRUPT.
0371 0408 8D 0E A0   STA IER
0372 040A A9 40      LDA #40   ;ENABLE TIMER1 IN FREE-RUN MODE.
0373 040C 8D 0E A0   STA ACR
0374 040F A9 FF      LDA #FF
0375 0411 8D 04 A0   STA TILL ;SET LOW LATCH ON TIMER 1.
0376 0414 8D 05 A0   STA T1CH ;SET HIGH LATCH & START INTERRUPT COUNT.
0377 0417 58        CLI      ;ENABLE INTERRUPTS.
0378 0419 D8        CLD
0379 041B 60        RTS
0380 041C           ;
0381 041C           ; ***** SUBROUTINE 'RANDOM' *****
0382 041C           ; RANDOM NUMBER GENERATOR; RETURNS NEW
0383 041C           ; RANDOM NUMBER IN ACCUMULATOR.
0384 041C           ;
0385 041C 38        RANDOM SEC
0386 041E A5 33      LDA RNDSR+1
0387 0420 45 36      ADC RNDSR+4
0388 0423 45 37      ADC RNDSR+5
0389 0426 85 32      STA RNDSR
0390 0428 A2 04      LDX #4

```

Fig. 11.50: Tic-Tac-Toe Program (Continued)

```

0391 00A5 B5 32      RNILP LDA RNDSCR,X
0392 00A7 95 33      STA RNDSCR+1,X
0393 00A9 CA         DEX
0394 00AA 10 F9      BFL RNILP
0395 00AC 60         RTS
0396 00AD           ;
0397 00AD           ; ***** SUBROUTINE 'TONE' *****
0398 00AD           ; GENERATES A TONE: NO. OF 1/2 CYCLES
0399 00AD           ; MUST BE IN DUR, AND
0400 00AD           ; WAVELENGTH CONST. IN ACCUMULATOR.
0401 00AD           ;
0402 00AD B5 3F      TONE STA FREQ
0403 00AF A9 FF      LDA #FF
0404 00B1 8D 00 AC   STA PORT3B
0405 00B4 A9 00      LDA #00
0406 00B6 A6 3E      FL2 LDX DUR
0407 00BB A4 3F      FL2 LDY FREQ
0408 00BA 88         FL1 DEY
0409 00BB 18         CLC
0410 00BC 90 00      BCC *+2
0411 00BE D0 FA      BNE FL1
0412 00C0 49 FF      EOR #FF
0413 00C2 8D 00 AC   STA PORT3B
0414 00C5 CA         DEX
0415 00C6 D0 F0      BNE FL2
0416 00C8 60         RTS
0417 00C9           .END

```

SYMBOL TABLE

SYMBOL VALUE

| SYMBOL | VALUE |
|-----------------|--|
| ACCESS | 8886 ACR A00B ADDR0W 0359 ANALYZ 029D |
| CHEKLP | 0314 CLRALL 0054 CLREND 0040 CLRLP 030C |
| CLRST | 0018 CNTSUB 0339 COMPMV 0226 DRR1A 0003 |
| DRR1B | A002 DRR3B AC02 DELAY 03A4 DL1 03A6 |
| DL2 | 03A8 DLY 0297 DONE 0303 DUR 003E |
| FINDMV | 0304 FL1 008A FL2 0088 FNMTCH 032F |
| FOUND | 0338 FREQ 003F GETKEY 0100 GMRD 0018 |
| GTHSK | 0269 IER A00E INIT 0050 INTDN 025F |
| INTEL | 0041 INTVEC 03B3 IRQVH A67F IRQVL A67E |
| KEYIN | 0389 LEDLTR 036F LIGHT 0398 LTMSKH 003C |
| LTMSKL | 003D LTRDN 037F MOVNUM 003A NOBLNK 0354 |
| NOCHK | 032A NOCNT 033F ODDMSK 0040 ODDRND 02EE |
| OK | 02C7 PLAYLP 0212 PLAYR 003B PLRMV 0380 |
| PORT1A | A001 PORT1B A000 PORT3B AC00 RANDOM 009A |
| RESTRT | 0204 RNILP 00A5 RNDMV 02F2 RNDSCR 0032 |
| ROWSUM | 002A RWPT1 0000 RWPT2 0008 RWPT3 0010 |
| SHIFT | 039D SQSTAT 0021 START 0200 TICH A005 |
| TILL | A004 TEMP1 0038 TEMP2 0039 TONE 00AD |
| TRAPCK | 02DD TSTLP 0237 UPDATE 0340 WIN 024B |
| WINTST | 0235 |
| END OF ASSEMBLY | |

<

Fig. 11.50: Tic-Tac-Toe Program (Continued)

APPENDIX A

6502 INSTRUCTIONS—ALPHABETIC

| | | | |
|------------|--------------------------|------------|------------------------|
| ADC | Add with carry | JSR | Jump to subroutine |
| AND | Logical AND | LDA | Load accumulator |
| ASL | Arithmetic shift left | LDX | Load X |
| BCC | Branch if carry clear | LDY | Load Y |
| BCS | Branch if carry set | LSR | Logical shift right |
| BEQ | Branch if result = 0 | NOP | No operation |
| BIT | Test bit | ORA | Logical OR |
| BMI | Branch if minus | PHA | Push A |
| BNE | Branch if not equal to 0 | PHP | Push P status |
| BPL | Branch if plus | PLA | Pull A |
| BRK | Break | PLP | Pull P status |
| BVC | Branch if overflow clear | ROL | Rotate left |
| BVS | Branch if overflow set | ROR | Rotate right |
| CLC | Clear carry | RTI | Return from interrupt |
| CLD | Clear decimal flag | RTS | Return from subroutine |
| CLI | Clear interrupt disable | SBC | Subtract with carry |
| CLV | Clear overflow | SEC | Set carry |
| CMP | Compare to accumulator | SED | Set decimal |
| CPX | Compare to X | SEI | Set interrupt disable |
| CPY | Compare to Y | STA | Store accumulator |
| DEC | Decrement memory | STX | Store X |
| DEX | Decrement X | STY | Store Y |
| DEY | Decrement Y | TAX | Transfer A to X |
| EOR | Exclusive OR | TAY | Transfer A to Y |
| INC | Increment memory | TSX | Transfer SP to X |
| INX | Increment X | TXA | Transfer X to A |
| INY | Increment Y | TXS | Transfer X to SP |
| JMP | Jump | TYA | Transfer Y to A |

APPENDIX B

6502—INSTRUCTION SET: HEX AND TIMING

| MNEMONIC | IMPLIED | | | ACCUM. | | | ABSOLUTE | | | ZERO PAGE | | | IMMEDIATE | | | ABS. X | | | ABS. Y | | |
|----------|---------|----|---|--------|---|---|----------|---|---|-----------|---|---|-----------|---|---|--------|---|---|--------|---|---|
| | OP | n | # | OP | n | # | OP | n | # | OP | n | # | OP | n | # | OP | n | # | OP | n | # |
| ADC | (1) | | | | | | 6D | 4 | 3 | 65 | 3 | 2 | 69 | 2 | 2 | 7D | 4 | 3 | 79 | 4 | 3 |
| AND | (1) | | | | | | 2D | 4 | 3 | 25 | 3 | 2 | 29 | 2 | 2 | 3D | 4 | 3 | 39 | 4 | 3 |
| ASL | | | | 0A | 2 | 1 | 0E | 6 | 3 | 06 | 5 | 2 | | | | 1E | 7 | 3 | | | |
| BCC | (2) | | | | | | | | | | | | | | | | | | | | |
| BCS | (2) | | | | | | | | | | | | | | | | | | | | |
| BEQ | (2) | | | | | | 2C | 4 | 3 | 24 | 3 | 2 | | | | | | | | | |
| BIT | | | | | | | | | | | | | | | | | | | | | |
| BMI | (2) | | | | | | | | | | | | | | | | | | | | |
| BNE | (2) | | | | | | | | | | | | | | | | | | | | |
| BPL | (2) | | | | | | | | | | | | | | | | | | | | |
| BRK | (2) | 00 | 7 | 1 | | | | | | | | | | | | | | | | | |
| BVC | (2) | | | | | | | | | | | | | | | | | | | | |
| BVS | (2) | | | | | | | | | | | | | | | | | | | | |
| CLC | | 18 | 2 | 1 | | | | | | | | | | | | | | | | | |
| CLD | | D8 | 2 | 1 | | | | | | | | | | | | | | | | | |
| CLT | | 58 | 2 | 1 | | | | | | | | | | | | | | | | | |
| CLV | | 88 | 2 | 1 | | | | | | | | | | | | | | | | | |
| CMV | | | | | | | CD | 4 | 3 | C5 | 3 | 2 | C9 | 2 | 2 | DD | 4 | 3 | D9 | 4 | 3 |
| CPX | | | | | | | EC | 4 | 3 | E4 | 3 | 2 | EO | 2 | 2 | | | | | | |
| CPY | | | | | | | CC | 4 | 3 | C4 | 3 | 2 | CO | 2 | 2 | | | | | | |
| DEC | | | | | | | CE | 6 | 3 | C6 | 5 | 2 | | | | DE | 7 | 3 | | | |
| DEX | | CA | 2 | 1 | | | | | | | | | | | | | | | | | |
| DEY | | 88 | 2 | 1 | | | | | | | | | | | | | | | | | |
| EOR | (1) | | | | | | 4D | 4 | 3 | 45 | 3 | 2 | 49 | 2 | 2 | 5D | 4 | 3 | 59 | 4 | 3 |
| INC | | | | | | | EE | 6 | 3 | E6 | 5 | 2 | | | | FE | 7 | 3 | | | |

| (IND. X) | | | (IND. Y) | | | Z. PAGE, X | | | RELATIVE | | | INDIRECT | | | Z. PAGE, Y | | | PROCESSOR STATUS CODES | | | | | | | MNEMONIC | |
|----------|---|---|----------|---|---|------------|---|---|----------|---|---|----------|---|---|------------|---|---|------------------------|---|---|---|---|---|---|----------|-----|
| OP | n | # | OP | n | # | OP | n | # | OP | n | # | OP | n | # | OP | n | # | N | V | B | D | I | Z | C | | |
| 61 | 6 | 2 | 71 | 5 | 2 | 75 | 4 | 2 | | | | | | | | | | • | • | | | | | | ADC | |
| 21 | 6 | 2 | 31 | 5 | 2 | 35 | 4 | 2 | | | | | | | | | | • | • | | | | | | AND | |
| | | | | | | 16 | 6 | 2 | | | | | | | | | | • | • | | | | | | ASL | |
| | | | | | | | | | 90 | 2 | 2 | | | | | | | | | | | | | | BCC | |
| | | | | | | | | | BO | 2 | 2 | | | | | | | | | | | | | | BCS | |
| | | | | | | | | | | | | | | | | | | | | | | | | | BEQ | |
| | | | | | | | | | | | | | | | | | | M | M | | • | | | | BIT | |
| | | | | | | | | | | | | | | | | | | | | | | | | | BMI | |
| | | | | | | | | | | | | | | | | | | | | | | | | | BNE | |
| | | | | | | | | | | | | | | | | | | | | | | | | | BPL | |
| | | | | | | | | | | | | | | | | | | | | | | | | | BRK | |
| | | | | | | | | | | | | | | | | | | | | | | | | | BVC | |
| | | | | | | | | | | | | | | | | | | | | | | | | | BVS | |
| | | | | | | | | | | | | | | | | | | | | | | | | | CLC | |
| | | | | | | | | | | | | | | | | | | | | | | | | | CLD | |
| | | | | | | | | | | | | | | | | | | | | | | | | | CLI | |
| C1 | 6 | 2 | D1 | 5 | 2 | D5 | 4 | 2 | | | | | | | | | | | | | | | | | CLV | |
| | | | | | | | | | | | | | | | | | | | | | | | | | | CMP |
| | | | | | | | | | | | | | | | | | | | | | | | | | | CPX |
| | | | | | | | | | | | | | | | | | | | | | | | | | | CPY |
| | | | | | | | | | | | | | | | | | | | | | | | | | | DEC |
| | | | | | | | | | | | | | | | | | | | | | | | | | | DEX |
| | | | | | | | | | | | | | | | | | | | | | | | | | | DEY |
| | | | | | | | | | | | | | | | | | | | | | | | | | | EOR |
| | | | | | | | | | | | | | | | | | | | | | | | | | | INC |

| | | | | | | | | | | | | | | | | | | | | | | | | | | |
|-----|-----|----|---|---|----|---|----|---|---|----|---|---|----|---|---|----|---|---|----|---|---|--|--|--|-----|-----|
| INX | | E8 | 2 | 1 | | | | | | | | | | | | | | | | | | | | | | INX |
| INY | | C8 | 2 | 1 | | | | | | | | | | | | | | | | | | | | | | INY |
| JMP | | | | | | | | | | | | | | | | | | | | | | | | | | JMP |
| JSR | | | | | | | | | | | | | | | | | | | | | | | | | | JSR |
| LDA | (1) | | | | | | 4C | 3 | 3 | A5 | 3 | 2 | A9 | 2 | 2 | BD | 4 | 3 | B9 | 4 | 3 | | | | LDA | |
| LDX | (1) | | | | | | AE | 4 | 3 | A6 | 3 | 2 | A2 | 2 | 2 | | | | | | | | | | | LDX |
| LDY | (1) | | | | | | AC | 4 | 3 | A4 | 3 | 2 | A0 | 2 | 2 | BC | 4 | 3 | | | | | | | | LDY |
| LSR | | | | | | | 4E | 6 | 3 | 46 | 5 | 2 | | | | 5E | 7 | 3 | | | | | | | | LSR |
| NOP | | EA | 2 | 1 | 4A | 2 | 1 | | | | | | | | | | | | | | | | | | | NOP |
| ORA | | | | | | | 0D | 4 | 3 | 05 | 3 | 2 | 09 | 2 | 2 | 1D | 4 | 3 | 19 | 4 | 3 | | | | | ORA |
| PHA | | 48 | 3 | 1 | | | | | | | | | | | | | | | | | | | | | | PHA |
| PHP | | 08 | 3 | 1 | | | | | | | | | | | | | | | | | | | | | | PHP |
| PLA | | 68 | 4 | 1 | | | | | | | | | | | | | | | | | | | | | | PLA |
| PLP | | 28 | 4 | 1 | | | | | | | | | | | | | | | | | | | | | | PLP |
| ROL | | | | | | | 2A | 2 | 1 | 2E | 6 | 3 | 26 | 5 | 2 | | | | | | | | | | | ROL |
| ROR | | | | | | | 6A | 2 | 1 | 6E | 6 | 3 | 66 | 5 | 2 | | | | | | | | | | | ROR |
| RTI | | | | | | | | | | | | | | | | | | | | | | | | | | RTI |
| RTS | | 40 | 6 | 1 | | | | | | | | | | | | | | | | | | | | | | RTS |
| SBC | (1) | 60 | 6 | 1 | | | | | | | | | | | | | | | | | | | | | | SBC |
| SEC | | 38 | 2 | 1 | | | | | | | | | | | | | | | | | | | | | | SEC |
| SED | | F8 | 2 | 1 | | | | | | | | | | | | | | | | | | | | | | SED |
| SET | | 78 | 2 | 1 | | | | | | | | | | | | | | | | | | | | | | SET |
| STA | | | | | | | 8D | 4 | 3 | 85 | 2 | | | | | | | | | | | | | | | STA |
| STX | | | | | | | 8E | 4 | 3 | 86 | 2 | | | | | | | | | | | | | | | STX |
| STY | | | | | | | 8C | 4 | 3 | 84 | 2 | | | | | | | | | | | | | | | STY |
| TAX | | AA | 2 | 1 | | | | | | | | | | | | | | | | | | | | | | TAX |
| TAY | | A8 | 2 | 1 | | | | | | | | | | | | | | | | | | | | | | TAY |
| TSX | | BA | 2 | 1 | | | | | | | | | | | | | | | | | | | | | | TSX |
| TXA | | 8A | 2 | 1 | | | | | | | | | | | | | | | | | | | | | | TXA |
| TXS | | 9A | 2 | 1 | | | | | | | | | | | | | | | | | | | | | | |

INDEX

ACCESS, 170
 Ad hoc algorithm, 239
 Ad hoc programming, 238
 Analytical algorithm, 225
 ANALYZE, 263
 Array, 122
 Artificial intelligence, 224
 Assembler, 47
 Assembly, 12
 Audio feedback, 163
 Auxiliary Control Register, 174
 BEO, 154
 Binary number, 41
 Blackjack, 189
 Blackjack Program, 212
 BLIN
 Blink masks, 175
 BLINKER, 208
 Blinking, 274
 Blinking LEDs, 261
 Blip counter, 92
 Board analysis flowchart, 242
 Bounce, 13
 Bracket-filtering, 150
 Carry, 206
 Cassette recorder, 4
 CLI, 174
 CNTSUB, 55
 Complement, 73
 Complementation Table, 80
 Computing the Status, 271
 Constant symbols, 47
 Counter, 65, 101
 COUNTSUB, 273
 Current limiters, 11
 Decimal mode, 151
 Decision tables, 225
 DELAY, 56, 132, 211, 278
 Delay constant, 103
 Diagonal trap, 244
 Diagonals, 266
 DISPLAY, 118
 DISPLY, 119
 Do-nothing, 55
 Draw, 222
 Dual Counter, 92
 Duration, 148
 DURTAB, 144
 ECHO, 137
 Echo, 35
 Echo Program, 145
 ESP Tester, 139
 EVAL, 118, 126, 153
 Evaluating the board, 225
 Extra Sensory Perception, 139
 FINDMV, 264, 269
 FINDMV flowchart, 270
 First move, 235
 Free run, 198
 Free-running, 198
 Free-running mode, 171, 256
 Frequencies, 25
 Frequency, 22, 261
 Frequency and duration constants, 161
 Games Board, 2, 7
 GETKEY, 13, 149
 GETKEY Program, 17
 GMBRD, 252
 Heuristic strategy, 225
 Hexadecimal, 41
 Hexguess Program, 63
 IER, 171

IFR, 171
 Illegal key closure, 95
 Index, 159
 Indexed addressing, 37, 39, 122, 126
 Initialization, 198
 INITIALIZE, 279
 Intelligence level, 252, 260
 Interconnect, 4
 Interrupt, 198, 252, 261
 Interrupt Handler, 183, 211
 Interrupt handling, 198, 279
 Interrupt Registers, 174
 Interrupt-enable register, 256
 Interrupt-enabler, 171, 179, 256
 IQ level, 245, 265
 Jackpot, 100
 JMP, 154
 Key closure, 277
 Keyboard, 7
 Keyboard input routine, 13
 Labels, 47
 Latch, 65
 LED #9, 123
 LED Connection, 10
 LEDs, 8
 Levels of difficulty, 6
 LIGHT, 118, 132, 157, 274, 278
 LIGHTER, 276
 LIGHTR, 207
 LITE, 70, 182
 Loop counter, 92
 LOSE, 130
 Magic Square, 73
 MasterMind, 162
 Middle C, 23
 Mindbender, 162
 Mindbender Program, 184
 MOVE, 47
 Multiplication, 122
 Music Player, 20
 Music Program, 31
 Music theory, 23
 Nested loop delay, 39
 Nested loop design, 25
 NOTAB, 144
 Note duration, 159
 Note frequency, 159
 Note sequence, 139
 Parameters, 149
 Parts, 11
 Perfect square, 73
 PLAY, 48, 53
 PLAYEM, 37
 Playing to the side, 24
 PLAYIT, 30, 38
 PLAYNOTE, 30
 PLRMV, 277
 Potential, 225
 Power supply, 4
 Programmable bracket, 101
 Prompt, 42
 Protected, 170
 Protected area, 170
 Pulse, duration, 171
 RANDB, 210
 RANDOM, 57, 135, 150, 159, 209
 Random moves, 241
 Random number, 54, 65, 78, 118, 267
 Random number generator, 57, 118, 149
 Random pattern, 73
 Random move, 267
 Recursion, 211
 Repeat, 13
 Resistors, 11
 RNDSCR, 252
 Row sequences, 251
 Row-sum, 239, 271
 SBC, 206
 Scratch area, 57
 Score, 107, 128
 Score table, 107, 111, 112
 SCORTB, 127
 Seed, 118, 149
 74154, 8
 7416, 8
 Shifting loop, 158
 SHOW, 152
 Side, 267
 Simple tunes, 21
 Siren, 100
 Slot Machine, 99
 Slot Machine Program, 113
 Software filter, 175
 Special decimal mode, 150
 Spinner, 87
 Spinner Program, 93
 SQSTAT, 252

Square status, 269
 Square wave, 22
 Strategy, 225
 SYM, 4
 TICL, 6, 83
 TIL-L, 65
 Threat potential, 226
 Tic-Tac-Toe, 218
 Tic-Tac-Toe Flowchart, 248
 Tic-Tac-Toe Program, 280
 TIMER, 65
 Timer, 65, 83, 198, 256
 Timer 1, 175
 TONE, 39, 70, 130, 135
 Translate, 41
 Translate Program, 49
 Trap, 235, 239, 264, 267
 Trap pattern, 241
 Two-level loop, 211
 Two-ply analysis, 237
 Unprotect system, 198
 UPDATE, 273
 Value computation, 226
 VIA, 8
 VIA memory map, 66
 Visual feedback, 163
 WAIT, 98
 Wheel pointer, 103, 120
 WIN, 128
 Win, 259
 Win potential, 225
 WINEND, 129

SYBEX BIBLIOGRAPHY

VIDEO COURSES

Microprocessors – 12 hours (Ref. VI)
 Military Microprocessor Systems – 6 hours (Ref. V3)
 Bit-Slice – 6 hours (Ref. V5)
 Microprocessor Interfacing Techniques – 6 hours (Ref. V7)

AUDIO COURSES

Introduction to Microprocessors – 2½ hours (Ref. S1)
 Programming Microprocessors – 2½ hours (Ref. S2)
 Designing a Microprocessor – 2½ hours (Ref. S3)
 Microprocessors – 12 hours (Ref. SB1)
 Programming Microprocessors – 10 hours (Ref. SB2)
 Military Microprocessor Systems – 6 hours (Ref. SB3)
 Bit-Slice – 6 hours (Ref. SB5)
 Industrial Microprocessor Systems – 4½ hours (Ref. SB6)
 Microprocessor Interfacing Techniques – 6 hours (Ref. SB7)
 Introduction to Personal Computing – 2½ hours (Ref. SB10)

REFERENCE TEXTS

Practical Pascal (Ref. C102)
 Introduction to Personal and Business Computing (Ref. C200)
 Microprocessors (Ref. C201)
The 6502 Series
 Volume-1: Programming the 6502 (Ref. C202)
 Volume-2: Programming Exercises for the 6502 (Ref. C203)
 Volume-3: 6502 Applications Book (Ref. D302)
 Volume-4: 6502 Games (Ref. G402)
 Microprocessor Interfacing Techniques (Ref. C207)
 Programming the Z80 (Ref. C280)
 Programming the Z8000 (Ref. C281)
 CP/M Handbook – with MP/M (Ref. D300)
 International Microprocessor Dictionary – 10 languages (Ref. IMD)
 Microprocessor Lexicon (Ref. X1)
 Microprogrammed APL Implementation (Ref. Z10)

SOFTWARE

BAS 65™ 6502 Assembler in Microsoft BASIC (Ref. BAS 65)
 8080 Simulator for KIM – Cassette Tape or 5" Diskette (Ref. S6580-KIM)
 8080 Simulator for APPLE – Cassette Tape or 5" Diskette (Ref. S6580-APL)

SELF-STUDY SYSTEM

Computeacher™ (Ref. CPT)
 Games Board™ (Ref. CPTG)

FOR A COMPLETE CATALOGUE OF OUR PUBLICATIONS

U.S.A.
2344 Sixth Street
Berkeley, California 94710
Tel: (415) 848-8233
Telex: 336311

EUROPE
18 rue Planchat
75020 Paris, France
Tel: (1) 3703275
Telex: 211801



SIG: 41 TZA1916

<17+>0511S3C851651580

19